

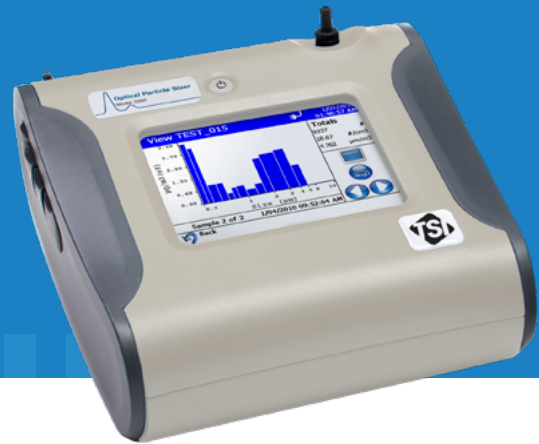

® Knowledge Beyond Measure.

Optical Particle Sizer

Model 3330



An easy-to-use particle sizer with superior resolution and adjustable size channels

The TSI® Optical Particle Sizer (OPS) 3330 is a light, portable unit that provides fast and accurate measurement of particle concentration and particle size distribution using single particle counting technology. Backed by over 40 years of aerosol instrumentation design experience, the OPS uses state-of-the-art optics with 120° light collection and sophisticated electronics processing resulting in precision, high quality data. Rigorous factory calibration standards ensure measurement accuracy.

Features and Benefits

- Size resolution < 5% at 0.5 μm
- User adjustable size channels
- Size range: 0.3 – 10 μm in up to 16 channels
- Wide concentration range from 0 to 3,000 particles/ cm^3
- Color touch screen with intuitive user interface
- Fully compliant with ISO 21501-1
- Displays particle number concentration and particle mass with the ability to input refractive index and particle density
- Filter-based sample collection for later gravimetric or chemical analysis
- Battery-powered for up to 20 hours of operation
- Built-in data logging capability for up to 30,000 samples
- Temperature and pressure recorded for every sample

Applications

Quality optical instruments are useful in a variety of applications due to their ease of use, fast measurement time, robustness, and reliability. A few common applications are listed below.

- Filter testing (i.e. ASHRAE 52.2)
- Industrial measurements
- Emissions monitoring and control



Proven Technology for Highly Resolved Particle Sizing

Operation

The sample aerosol is pulled straight into the measurement region of the OPS 3330 to reduce particle losses due to transport. A sheath flow surrounds the sample, focusing the aerosol to enhance size resolution, and keeping the optics clean for improved reliability and low maintenance. The flow rates in the OPS are carefully controlled using real-time feedback to ensure concentration accuracy. The temperature and humidity of the sample is measured and recorded. In the optical chamber, the aerosol crosses a laser beam, creating a light pulse. The intensity of the flash is used to count and size the particles. The shape of the laser beam, the size of the viewing volume, the type of detector and the signal processing algorithms in the model 3330 were designed to provide optimal resolution over the size range of 0.3 to 10 μm . The increased light collection ($90^\circ \pm 60^\circ$) reduces Mie scatter effects. After being sized, the sample flows from the optics chamber to the filter cartridge where it is collected on a 37 mm filter, for gravimetric analysis or further chemical or microscopic sample investigation.

Measurement Quality

In addition to improving the core measurement fundamentals of optical particle counters (OPCs), the model 3330 includes the ability to input the index of refraction and shape factor of the aerosol into the software to provide more accurate size distributions. The size boundaries can be adjusted using both real and imaginary components of refractive index. A unique density for every size channel can also be inputted into the software to further improve mass concentration measurement.

The model 3330 is manufactured at TSI's ISO 9001 certified facility. It is calibrated using NIST traceable PSL spheres and TSI's accredited Electrostatic Classifier and Condensation Particle Counters. PSL is the industry wide calibration aerosol of choice because it has properties close to many real world aerosols and is traceable to national standards throughout the world. Each OPS that leaves the factory is built for longevity, backed by TSI's commitment to quality, and supported by our worldwide network of committed TSI® professionals.

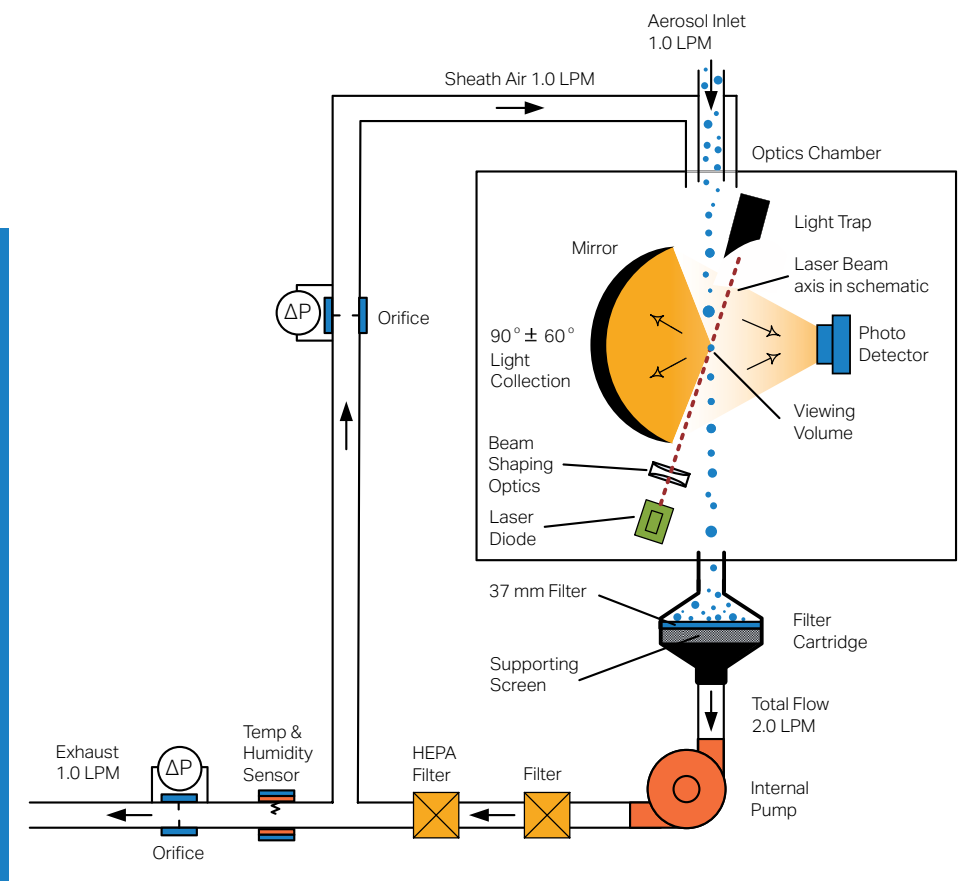

Easy to Program and Operate

The color touch-screen and user interface was designed to allow investigators to intuitively operate the instrument. The easy-to-read front panel shows real-time count and mass data in graphical or tabular format. Data can be shown as counts, concentration or normalized concentration in either linear or log format. The display gives status information on pump, laser, flow rate, and much more. From the instrument, users can program start times, total sampling times, an alarm set point and many other parameters. The internal memory can store sample records which can be conveniently viewed on screen or easily downloaded using a flash drive. Data can also be saved directly to a computer via a USB cable or Ethernet connection.

Powerful Software

TSI's particle instrument Aerosol Instrument Manager® Software now supports the OPS 3330. The Microsoft® Windows® 10 and 11, 64-bit compatible software controls instrument operation and provides file management capabilities. Live data graphs and data tables can be viewed from the PC. The data can be weighted by moments of number concentration including surface area and mass, and the software automatically calculates statistics on every data set.

Dilution factors, density and refractive index can be easily inputted. A handy playback feature allows a visual review of collected data, and new to this version, multiple samples can be viewed on the same graph for quick comparison. An export function with auto export option, allows easy transport of data files to spreadsheet or other application for customized data handling.

Featured Applications

- Filter Testing: The intrinsic resolution, wide concentration range, flow rate and fast measurement time make the OPS ideal for measuring upstream and downstream of filters or filter media. The model 3330 complies with the requirements for filter testing in accordance with ASHRAE 52.2.
- Industrial Measurements: Investigators from industry routinely need a quick, easy method to measure airborne particles. The model 3330 provides this type of industrial user a meaningful measurement at an affordable price.

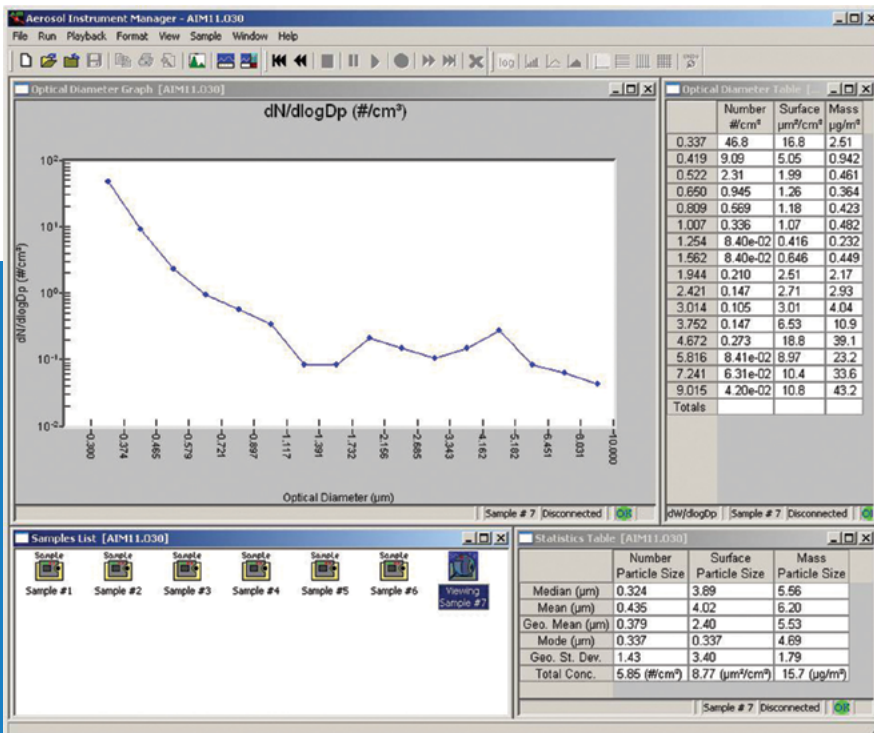

OPS Model 3330 Status Screen

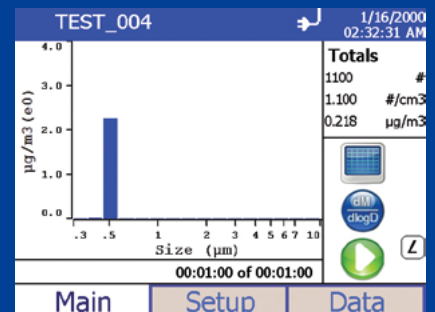

Mass size distribution for 0.49 µm ±9nm classified PSL spheres

Specifications

Optical Particle Sizer

Model 3330

Measurement Principle

120° light scatter and filter sampling

Particle Concentration Limit

Up to 3,000 particles/cm³ (3,000,000 particles/liter)

Mass Concentration

0.001 to 275,000 µg/m³

Particle Sizing

Particle Size Range	0.3 to 10 µm
Size Resolution	5% at 0.5 µm per ISO 21501-1
Size Channels	Up to 16, user-adjustable size channels

Sampling Time

≥ 1 second, user-adjustable

Zero Count

< 1 count per minute

Flow Rate

Sample	1.0 L/min; ±5% accuracy (meets ISO 21501)
Sheath	1.0 L/min

Environmental Conditions

Operational Temp	0 to 45° C (32 to 113° F)
Operational Humidity	0 to 96% RH, non-condensing
Storage Temp	-20 to 60° C (-4 to 140° F)

Aerosol Medium

Air only

Data Storage

5MB on-board memory (30,000 samples)

Communications

Interfaces	USB, Ethernet or USB flash drive
Digital Display	5.7 in. color touchscreen w/graphical display
Analog Output	0 to 5V or 4 to 20 mA. User selectable out-put and user selectable
Alarm Out	Visual indication, audible buzzer, relay or switch. User selectable set point

*NIST – National Institute of Standards and Technology

Aerosol Instrument Manager, TSI and the TSI logo are registered trademarks are trademarks of TSI Incorporated in the United States and may be protected under other country's trademark registrations.

Microsoft and Windows are registered trademarks of Microsoft Corporation in the United States and/or other countries.

Gravimetric Sampling

37 mm filter inside standard removable 37mm filter cartridge

Vacuum Source

Internal pump

Light Source

Long lasting laser diode

Power

This product must not be used in residential areas or connected to low voltage from the public mains network.

AC Adaptor 100-240 VAC, 50/60 Hz, 15W

Physical Features

Physical Size (H x W x D)	13.5 x 21.6 x 22.4 cm (5.3 x 8.5 x 8.8 in.)
Weight, Instrument	2.0 kg (4.4 lb)
Weight, Battery	0.5 kg (1 lb)

Battery Performance (Hot Swappable)

Runtime	1 battery up to 10 hours, 2 batteries up to 20 hours
Charge time	1 battery up to 4 hours, 2 batteries up to 8 hours

Software

Supplied with Aerosol Instrument Manager® Software for the OPS

Calibration

Annual calibration recommended at TSI using NIST* traceable materials and analytical tools

Included Accessories

Operation manual, power supply, battery, purge filter, USB cable, carrying case and Aerosol Instrument Manager software for the OPS

Optional Accessories

Additional battery, dual port external battery charger, and aerosol diluters

To Order

Optical Particle Sizer

Specify	Description
3330	Optical Particle Sizer

Optional Accessories

Specify	Description
801680	6600 mAh Li-ion Battery Pack
801685	External Battery Charger
3332-10	Dilution System (10:1 dilution ratio)
3332-100	Dilution System (100:1 dilution ratio)



Knowledge Beyond Measure.

TSI Incorporated - Visit our website www.tsi.com for more information.

USA	Tel: +1 800 874 2811	India	Tel: +91 80 67877200
UK	Tel: +44 149 4 459200	China	Tel: +86 10 8219 7688
France	Tel: +33 1 41 19 21 99	Singapore	Tel: +65 6595 6388
Germany	Tel: +49 241 523030		



Distributed by:

Kenelec Scientific Pty Ltd
1300 73 22 33
sales@kenelec.com.au
www.kenelec.com.au