

Indigo510 Transmitter

For Vaisala Indigo-compatible probes



Features

- Touchscreen display (optional non-display model with LED indicator also available)
- Data logging of all measurement parameters
- IP66 rated metal enclosure
- 2 configurable galvanically isolated analog outputs
- Ethernet connection with web interface and optional Vaisala cloud connectivity for remote monitoring
- Modbus[®] TCP/IP protocol
- Protective extra-low voltage powering
- UL Listed in USA and Canada

Vaisala Indigo510 Transmitter is an industrial-grade, robust transmitter that accommodates 1 Vaisala Indigo-compatible probe for humidity, temperature, dew point, carbon dioxide, hydrogen peroxide, and moisture in oil measurements. The transmitter can display measurements on the spot as well as transmit them to automation systems through analog signals or Modbus TCP/IP protocol.

Variety of probe options

The Indigo500 series transmitters are the most versatile option for use with Indigo-compatible probes.

- HMP series humidity and temperature probes
- DMP series dew point probes
- GMP250 series carbon dioxide probes
- HPP270 series vaporized hydrogen peroxide probes
- MMP8 moisture in oil probe

The probes are interchangeable, self-contained measurement instruments that are easily detachable from the transmitter for calibration and maintenance. The probes are connected using a cable that can be extended with a standard instrumentation cable to allow up to 30 m (98 ft) distance between the transmitter and the probe.

The Indigo500 series transmitters can be connected to the MHT410 transmitter for display of measurement data and automation system connectivity.

Through the transmitter service port, the Indigo500 series transmitters can also be connected to the free Vaisala Insight PC Software or Indigo80 Handheld Indicator.

For more information on the Indigo product family, see vaisala.com/indigo.

Analog and digital interfaces

The Indigo510 transmitter has 2 analog channels that can be configured to mA or voltage type. Any of the output parameters from the connected probe can be assigned to control the analog channels.

The digital output protocol is Modbus TCP/IP over Ethernet. The Ethernet connection also provides a web interface and cybersecurity that meets modern standards. The Indigo500 series transmitters can be ordered with a possibility for Vaisala cloud connection for remote monitoring.

Robust design

The transmitter has a wide operating temperature range, an IP66-rated corrosion-resistant metal enclosure, and an optional touchscreen display made of strengthened (IK08) glass.

The transmitter withstands commonly used cleaning chemicals, such as isopropanol and liquid H₂O₂ (30 %), and performs even in the harshest conditions.

The standard mounting options include mounting on a wall and on a DIN rail. With a retrofit mounting plate, the transmitter can be installed to replace an HMT330, DMT340, or MMT330 series transmitter. A pole mounting kit is also available as an accessory.

Technical data

Indigo-compatible probes

Measurement type	Probe models
Humidity and temperature	HMP1, HMP3, HMP4, HMP5, HMP7, HMP8, HMP9
Temperature	TMP1
Dew point	DMP1, DMP5, DMP6, DMP7, DMP8
Carbon dioxide	GMP251, GMP252
Vaporized hydrogen peroxide	HPP271, HPP272
Moisture in oil	MMP8

Other compatible devices

Device or series	Models
Moisture, Hydrogen and Temperature Transmitter MHT410	MHT410
Indigo80 Handheld Indicator	Indigo80

Transmitter options

Display	<ul style="list-style-type: none">Capacitive touchscreen displayNo display (indicator LED) ¹⁾
Powering	Protective extra-low voltage (11–35 V DC, 24 V AC ± 20 % 50/60 Hz)

¹⁾ Recommended when the transmitter is exposed to direct UV light, and for outdoor installations and high-humidity environments.

Mechanical specifications

Housing classification	IK08, DIN EN ISO 11997-1: Cycle B (VDA 621-415)
Housing material	AlSi10Mg (DIN 1725)
Display window material	Strengthened glass (IK08)
Weight	1.5 kg (3.3 lb)
Dimensions (H × W × D)	142 × 182 × 67 mm (5.63 × 7.17 × 2.64 in)

Cable diameters for cable glands

M20×1.5 glands	5.0–9.0 mm (0.20–0.35 in)
M20×1.5 glands with split bushing	7 mm (0.28 in)
M16×1.5 glands	2.0–6.0 mm (0.08–0.24 in)

Operating environment

Operating environment	Outdoor use
Use in wet location	Yes
Operating humidity	0–100 %RH
Maximum operating altitude	4000 m (approx. 13 100 ft)
IP rating	IP66 ¹⁾
UL 50E rating	Type 4

Operating temperature

With display	–20 ... +60 °C (–4 ... +140 °F)
Without display	–40 ... +60 °C (–40 ... +140 °F)

Storage temperature

With display	–30 ... +60 °C (–22 ... +140 °F)
Without display	–40 ... +60 °C (–40 ... +140 °F)

¹⁾ Evaluated by Eurofins, not by UL.

Powering

Operating power	
Protective extra-low voltage (PELV)	11–35 V DC, 24 V AC ±20 % 50/60 Hz, max. current 2 A (power supply is galvanically isolated) ¹⁾ Fuse size for power supply: 3 A Isolation voltage: 500 V AC, 1000 V DC
PELV power cable temp. rating	≥ +80 °C (+176 °F)

Typical current consumption at +20 °C (+68 °F) (U_{in} 24 V DC) ²⁾

Base consumption (no display, analog outputs, or communication)	50 mA
With display	+ 60 mA
With voltage analog output	< 2 mA per channel
With current analog output	+ 21 mA per channel
With Ethernet cable connected	+ 15 mA

¹⁾ The DNV type approval is valid in operating voltage range 15–35 V DC.

²⁾ For the current consumption of the connected measurement device, see the device's documentation, available at docs.vaisala.com.

Inputs and outputs

Transmitter service port connection	<ul style="list-style-type: none">Connection to Insight software with USB2 and cable 262195SP or with cable 219690 ¹⁾Connection to Indigo80 with cable 262195SP
-------------------------------------	---

Analog outputs

Number of analog outputs	2
Isolation	Isolated from power supply
Selectable voltage output types	0–1 V, 0–5 V, 0–10 V, scalable
Selectable current output types	4–20 mA, 0–20 mA, scalable
Max. wire size	2.5 mm ² (14 AWG)
Accuracy of analog outputs at +20 °C (+68 °F)	±0.05 % full scale
Temperature dependence	±0.005 % / °C full scale
External loads:	
Current outputs	R _L < 500 Ω
0–1 V output	R _L > 2 kΩ
0–5 V and 0–10 V outputs	R _L > 10 kΩ

Ethernet interface

Supported standards	10BASE-T, 100BASE-TX
Connector	8P8C (RJ45)
Supported protocols	Modbus TCP/IP (port 502), HTTPS (port 8443)
Vaisala cloud connectivity ²⁾	Requires outbound TCP port 443 and UDP port 123

¹⁾ Vaisala Insight PC Software for Windows® available at vaisala.com/insight.

²⁾ Available only for transmitters ordered with software configuration for Vaisala cloud connectivity.

User interfaces

User interfaces	Web interface, optional touchscreen display, optional Vaisala cloud connectivity for remote monitoring ¹⁾
Supported languages	English, Chinese (simplified), Chinese (traditional), French, German, Japanese, Spanish
Optional display	5" capacitive touchscreen
Integrated data logging capabilities	Non-volatile memory, at least 10 years' storage with 24 h interval logging

¹⁾ Available only for transmitters ordered with software configuration for Vaisala cloud connectivity.

Compliance

EU directives and regulations	EMC Directive (2014/30/EU) RoHS Directive (2011/65/EU) as amended by 2015/863
Electromagnetic compatibility (EMC)	IEC/EN 61326-1, industrial environment CISPR 32 / EN 55032, Class B
Electrical safety	IEC/EN 61010-1
Type approvals	DNV GL certificate no. TAA000032M EU RO Mutual Recognition certificate no. MRA000004F
Compliance marks	CE, China RoHS, FCC, RCM, UKCA
Listing marks	UL Listed (USA and Canada)
FCC compliance	FCC Part 15, Class B



Spare parts

Cable gland, M20×1.5, 5.0–9.0 mm (0.20–0.35 in)	ASM213670SP
Cable gland with split bushing, M20×1.5 ¹⁾	262632SP
Cable gland, M16×1.5, 2.0–6.0 mm (0.08–0.24 in)	ASM213671SP
Conduit fitting, M20×1.5 for NPT1/2" conduit	214780SP

¹⁾ With 7-mm (0.28 in) hole for cable and 14-mm (0.55 in) hole for 8P8C (RJ45) connector to pass through.

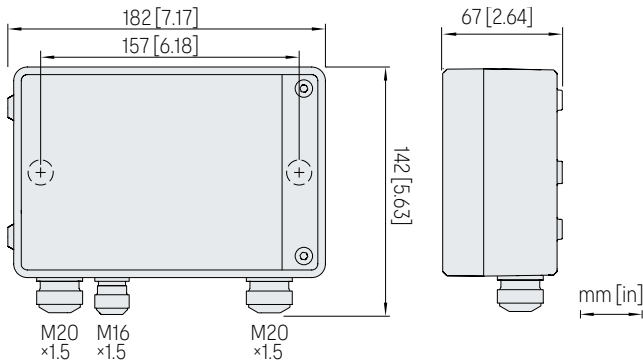

Indigo510 dimensions and lead-through sizes

Accessories

Retrofit mounting plate	DRW252186SP
Installation kit for pole or pipeline	215108
Installation kit with weather shield	215109
Indigo500 spatter guard	ASM214526
M12 - M8 service cable 1.5 m (4.9 ft), for connecting to Indigo80	262195SP
Vaisala Indigo USB adapter and M12 - M8 service cable, for connecting to Insight software	USB2 and 262195SP
M8 - USB service cable, for connecting to Insight software	219690

Probe connection cables

Probe connection cable, 0.3 m (approx. 12 in), open end ¹⁾	CBL210896-03MSP
Probe connection cable, 1 m (approx. 3 ft 3 in), open end ¹⁾	CBL210896-1MSP
Probe connection cable, 3 m (approx. 9 ft 10 in), open end ¹⁾	CBL210896-3MSP
Probe connection cable, 5 m (approx. 16 ft 5 in), open end ¹⁾	CBL210896-5MSP
Probe connection cable, 10 m (approx. 32 ft 10 in), open end ¹⁾	CBL210896-10MSP

¹⁾ The usable length outside of the transmitter enclosure is approx. 0.1 m (4 in) shorter than the total length of the cable.

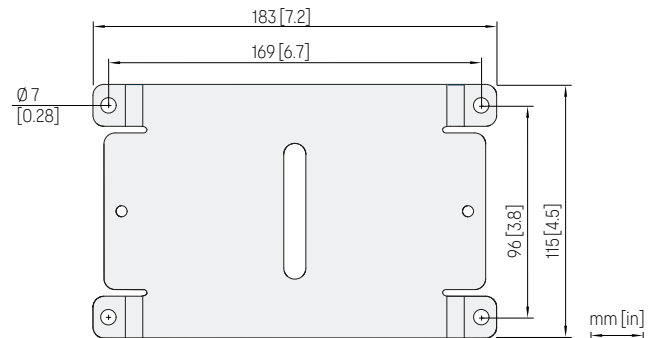

Indigo500 retrofit mounting plate dimensions

VAISALA

Published by Vaisala | B212305EN-K © Vaisala 2025

All rights reserved. Any logos and/or product names are trademarks of Vaisala or its individual partners. Any reproduction, transfer, distribution or storage of information contained in this document is strictly prohibited. All specifications – technical included – are subject to change without notice.



Distributed by:
Kenelec Scientific Pty Ltd
1300 73 22 33
sales@kenelec.com.au
www.kenelec.com.au