

GAS DETECTION REMOTE DEVICES DATASHEET

RPS-24VDC Remote Power Supply



The RPS-24VDC is a remote power supply for large fixed system applications and/or very long wire runs. It converts 90 - 240 VAC power to 24 VDC power, providing a renewed amount of power to compensate for voltage drops. Projects requiring a large number of gas detectors or consist of very long wire runs require a remote power supply to boost the voltage to the last transmitter on the network run and to reinforce the voltage provided by the Controller to the first line of transmitters.

The RPS-24VDC comes in a standard water / dust tight, corrosion resistant ABS / polycarbonate enclosure with a hinged, secured door.

KEY FEATURES

- » Supplies power to a large gas detection system
- » Boosts power on long wire runs that present a voltage loss condition
- » Standard, dust / water tight, corrosion resistant enclosure drip proof)

TECHNICAL SPECIFICATIONS

MECHANICAL

Enclosure	ABS / Polycarbonate. Copper coated interior to reduce RF interference.
Weight	1.4 kg (3.0 lbs)
Size	254 x 218 x 109 mm / 10.0 x 8.6 x 4.3 in

ELECTRICAL

Power Requirement	90 - 240 VAC, 75 W 50 - 60 Hz, Line Voltage
Output	24 VDC, 65 W
Wiring	4-wire shielded in conduit network wiring between the devices
Fuses	Thermal, resetting

ENVIRONMENTAL

Operating Temperature	-20°C to 40°C (-4°F to 104°F)
Humidity	20 to 90% non-condensing

CERTIFICATION

CSA, UL, CE, FCC

TECHNICAL DRAWING

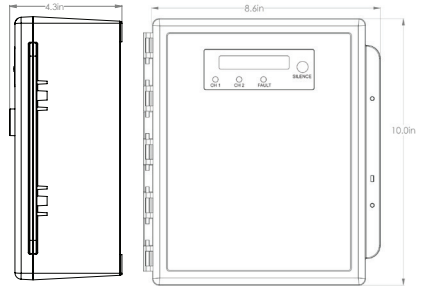

WIRING DIAGRAMS

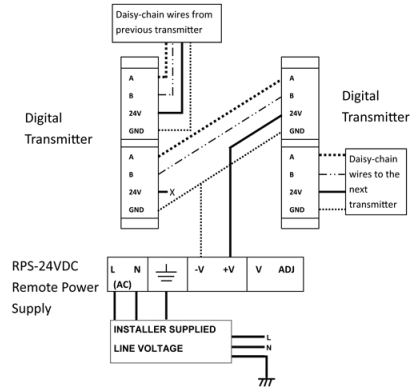

PRODUCT CODES

RPS-24VDC	Remote Power Supply output 24 VDC, 65 W
-----------	--

