

# User Guide

Vaisala CARBOCAP® Carbon Dioxide, Humidity, and Temperature Transmitters

**GMW80 Series**

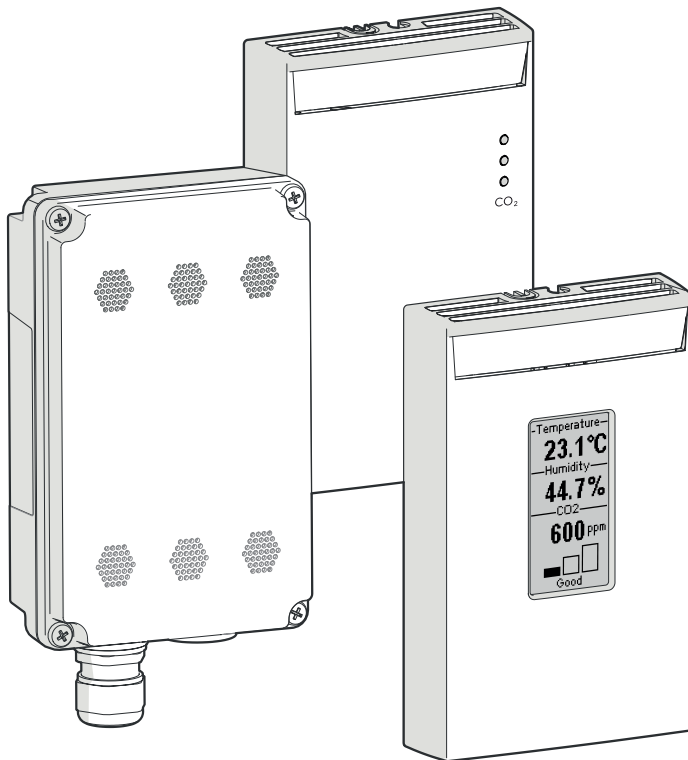

PUBLISHED BY

Vaisala Oyj  
Vanha Nurmijärventie 21, FI-01670 Vantaa, Finland  
P.O. Box 26, FI-00421 Helsinki, Finland  
+358 9 8949 1

Visit our Internet pages at [www.vaisala.com](http://www.vaisala.com).

© Vaisala 2020

No part of this document may be reproduced, published or publicly displayed in any form or by any means, electronic or mechanical (including photocopying), nor may its contents be modified, translated, adapted, sold or disclosed to a third party without prior written permission of the copyright holder. Translated documents and translated portions of multilingual documents are based on the original English versions. In ambiguous cases, the English versions are applicable, not the translations.

The contents of this document are subject to change without prior notice.

Local rules and regulations may vary and they shall take precedence over the information contained in this document. Vaisala makes no representations on this document's compliance with the local

rules and regulations applicable at any given time, and hereby disclaims any and all responsibilities related thereto.

This document does not create any legally binding obligations for Vaisala towards customers or end users. All legally binding obligations and agreements are included exclusively in the applicable supply contract or the General Conditions of Sale and General Conditions of Service of Vaisala.

This product contains software developed by Vaisala or third parties. Use of the software is governed by license terms and conditions included in the applicable supply contract or, in the absence of separate license terms and conditions, by the General License Conditions of Vaisala Group.

## Table of contents

<b>1.</b>	<b>About this document</b> .....	5
1.1	Version information.....	5
1.2	Related manuals.....	5
1.3	Documentation conventions.....	5
1.4	Trademarks.....	6
1.5	Patent notice.....	6
<b>2.</b>	<b>Product overview</b> .....	7
2.1	Introduction to GMW80 series.....	7
2.1.1	Transmitter parts.....	9
2.1.2	GMW87 and GMW88 transmitter parts.....	10
2.2	Display.....	12
2.2.1	Startup screens.....	13
2.2.2	Measurement screen.....	13
2.2.3	Error messages.....	14
2.3	Relay.....	15
2.4	CO <sub>2</sub> level indicator LEDs.....	16
2.5	Analog output overrange behavior.....	17
2.6	Safety.....	20
2.7	Regulatory compliance.....	21
<b>3.</b>	<b>Installation</b> .....	22
3.1	Selecting location.....	22
3.2	Opening and closing the transmitter.....	23
3.3	Installing the mounting base.....	24
3.4	Installing GMW87 and GMW88.....	26
3.5	Wiring.....	27
3.5.1	Wiring GMW83, GMW83D, and GMW83A.....	29
3.5.2	Wiring GMW83RP and GMW83DRP.....	30
3.5.3	Wiring GMW84.....	30
3.5.4	Wiring GMW84S.....	31
3.5.5	Wiring GMW86P.....	32
3.5.6	Wiring GMW87.....	33
3.5.7	Wiring GMW88.....	33
<b>4.</b>	<b>Modbus communication</b> .....	34
<b>5.</b>	<b>Maintenance</b> .....	36
5.1	Cleaning.....	36
5.2	Replacing the CO <sub>2</sub> measurement module (GM10).....	36
5.3	Replacing the INTERCAP humidity sensor.....	37
<b>6.</b>	<b>Troubleshooting</b> .....	39
6.1	Solving typical problems.....	39
6.2	Error state.....	42

- 7. Technical data..... 43**
- 7.1 Specifications..... 43
- 7.2 Spare parts and accessories..... 46
- 7.3 Dimensions..... 47
  
- Appendix A: Modbus reference..... 49**
- A.1 Function codes..... 49
- A.2 Data encoding..... 49
  - A.2.1 32-bit floating point format..... 49
  - A.2.2 16-bit integer format..... 50
- A.3 Modbus registers..... 50
  - A.3.1 Measurement data registers..... 50
  - A.3.2 Status registers..... 51
  - A.3.3 Test value registers..... 51
- A.4 Device identification objects..... 52
- A.5 Modbus communication example..... 53
  
- Maintenance and calibration services..... 55**
  
- Warranty..... 55**
  
- Technical support..... 55**
  
- Recycling..... 55**

## List of figures

Figure 1	GMW80 series transmitter parts.....	9
Figure 2	GMW80 series component board parts.....	10
Figure 3	GMW87 transmitter parts.....	11
Figure 4	GMW88 transmitter parts.....	12
Figure 5	Example startup screens.....	13
Figure 6	Example measurement screens.....	14
Figure 7	Example error message on display.....	14
Figure 8	Relay indicator LED on GMW84S.....	15
Figure 9	Rotary switch.....	15
Figure 10	CO <sub>2</sub> level indicator LEDs on model GMW83A.....	16
Figure 11	Overrange behavior of CO <sub>2</sub> measurement with 4 ... 20 mA output.....	17
Figure 12	Overrange behavior of CO <sub>2</sub> measurement with 0 ... 10 V output.....	18
Figure 13	Overrange behavior of active temperature measurement.....	19
Figure 14	Overrange behavior of relative humidity measurement.....	20
Figure 15	Examples of good installation locations.....	22
Figure 16	Examples of unsuitable installation locations.....	23
Figure 17	Mounting GMW87 and GMW88.....	26
Figure 18	Routing the cable from behind (GMW83, GMW84, and GMW86 models).....	27
Figure 19	Locations of the breakaway tabs.....	28
Figure 20	Wiring from below with cable tie strain relief .....	29
Figure 21	Wiring for GMW83, GMW83D, and GMW83A.....	29
Figure 22	Wiring for GMW83RP and GMW83DRP.....	30
Figure 23	Wiring for GMW84.....	30
Figure 24	Wiring for GMW84S.....	31
Figure 25	Wiring for GMW86P.....	32
Figure 26	Wiring for GMW87.....	33
Figure 27	Wiring for GMW88.....	33
Figure 28	GMW87 component board with DIP switches and screw terminals.....	34
Figure 29	Modbus device address DIP switch example.....	35
Figure 30	Disconnecting the GM10 module.....	36
Figure 31	Dimensions for GMW83, GMW83A, GMW83RP, GMW84, GMW84S, and GMW86P.....	47
Figure 32	Dimensions for GMW83D and GMW83DRP.....	47
Figure 33	Dimensions for GMW87 and GMW88.....	48

## List of tables

Table 1	Document versions (English).....	5
Table 2	Applicable patents or applications.....	6
Table 3	GMW80 series transmitters.....	7
Table 4	Relay setpoints.....	15
Table 5	Troubleshooting table, transmitters with analog output.....	39
Table 6	Troubleshooting table, transmitter model GMW87.....	41
Table 7	GMW80 models.....	43
Table 8	GMW80 measurement performance.....	43
Table 9	GMW80 compliance.....	44
Table 10	GMW80 operating environment.....	44
Table 11	GMW80 inputs and outputs.....	45
Table 12	GMW80 mechanical specifications.....	46
Table 13	Modbus function codes.....	49
Table 14	Interpretation of 16-bit signed integer values.....	50
Table 15	Modbus measurement data registers (read-only).....	50
Table 16	Modbus status registers (read-only).....	51
Table 17	Modbus test registers (read-only).....	51
Table 18	Device identification objects.....	52

# 1. About this document

## 1.1 Version information

This document provides detailed instructions for using and maintaining Vaisala CARBOCAP® Carbon Dioxide, Temperature, and Humidity Transmitter Series GMW80 devices.

Table 1 Document versions (English)

Document code	Date	Description
M211748EN-G	November 2020	This manual. Information on new product model GMW87 added throughout the document. Note about use of shielded cables added in <a href="#">Wiring (page 27)</a> . Added sections <a href="#">Modbus communication (page 34)</a> and <a href="#">Modbus reference (page 49)</a> . Updated section <a href="#">Technical data (page 43)</a> .
M211748EN-F	January 2018	Previous version. Added new product model GMW88. Wiring and mounting instructions updated. Document template updated. Removed product models GMW83T and GMW86PT.
M211748EN-D	November 2015	Added new product models: GMW84 and GMW84S.

## 1.2 Related manuals

Document code	Name
M211660EN	<i>Vaisala Carbon Dioxide Module GM10 Quick Reference Guide</i>

## 1.3 Documentation conventions



**WARNING! Warning** alerts you to a serious hazard. If you do not read and follow instructions carefully at this point, there is a risk of injury or even death.



**CAUTION! Caution** warns you of a potential hazard. If you do not read and follow instructions carefully at this point, the product could be damaged or important data could be lost.



**Note** highlights important information on using the product.

## 1.4 Trademarks

Vaisala®, CARBOCAP®, and INTERCAP® are registered trademarks of Vaisala Oyj.

Modbus® is a registered trademark of Schneider Automation Inc.

All other product or company names that may be mentioned in this publication are trade names, trademarks, or registered trademarks of their respective owners.

## 1.5 Patent notice

This product is protected by the following patents and patent applications and their corresponding national rights:

Table 2 Applicable patents or applications

Issuing office	Publication number
United States Patent and Trademark Office	US 5,827,438
	US 6,177,673
European Patent Office	EP0776023
	EP0922972
German Patent and Trade Mark Office	69615635
Japan Patent Office	4263285
Finnish Patent Office	112005
	105598



## 2. Product overview

### 2.1 Introduction to GMW80 series

Vaisala GMW80 series CARBOCAP® carbon dioxide, humidity, and temperature transmitters are wall-mount transmitters designed to fulfill the needs for CO<sub>2</sub> measurements in standard demand controlled ventilation applications.

The following table lists the GMW80 series transmitters and their features.

Table 3 GMW80 series transmitters

Model name	CO <sub>2</sub> output	T output	RH output	Display	CO <sub>2</sub> LEDs	Relay	T setpoint
GMW83	0 ... 10 V	0 ... 10 V	No	No	No	No	No
GMW83A	0 ... 10 V	0 ... 10 V	No	No	Yes	No	No
GMW83D	0 ... 10 V	0 ... 10 V	No	Yes <sup>1)</sup>	No	No	No
GMW83RP	0 ... 10 V	0 ... 10 V Pt1000 (passive)	0 ... 10 V	No	No	No	No
GMW83DRP	0 ... 10 V	0 ... 10 V Pt1000 (passive)	0 ... 10 V	Yes <sup>1)</sup>	No	No	No
GMW84	4 ... 20 mA	4 ... 20 mA	No	No	No	No	No
GMW84S	4 ... 20 mA	4 ... 20 mA	No	No	No	Yes	No
GMW86P	4 ... 20 mA 0 ... 10 V	Pt1000 (passive)	No	No	No	No	No
GMW87	RS-485 Modbus RTU output	No	No	No	No	No	No
GMW88	4 ... 20 mA 0 ... 10 V	No	No	No	No	No	No

<sup>1)</sup> Temperature measurement data displayed in Celsius scale only.

Letters at the end of the model name stand for the following features:

- P Passive temperature measurement
- D Display
- A CO<sub>2</sub> indicator LEDs
- R Humidity measurement
- S Relay

The CO<sub>2</sub> measurement is based on the Vaisala proprietary CARBOCAP® sensor, which uses a novel, silicon-based microchip emitter instead of an incandescent light bulb. The internal reference in the CO<sub>2</sub> sensor guarantees the best stability and operation also in constantly occupied buildings without frequent readjustments.

CARBOCAP® sensors give correct CO<sub>2</sub> measurements immediately when powered on. As they have a built-in reference measurement, they do not need a lengthy learning phase before the measured values are correct. Proper operation can be verified immediately after snapping on the device cover.

All GMW80 series transmitters measure carbon dioxide (CO<sub>2</sub>) and temperature (T) with the exception of GMW87 and GMW88, which measure only CO<sub>2</sub>. Certain models also include relative humidity (RH) measurement. Humidity measurement utilizes the Vaisala INTERCAP® sensor.

For measurements in more demanding conditions (for example, dusty or humid installation locations), the GMW87 and GMW88 models provide an IP64-rated enclosure with a cable gland. The GMW87 model can be accessed with the Modbus RTU protocol over an RS-485 interface. The communication settings for the protocol are entered with DIP switches on the GMW87 component board.

## 2.1.1 Transmitter parts

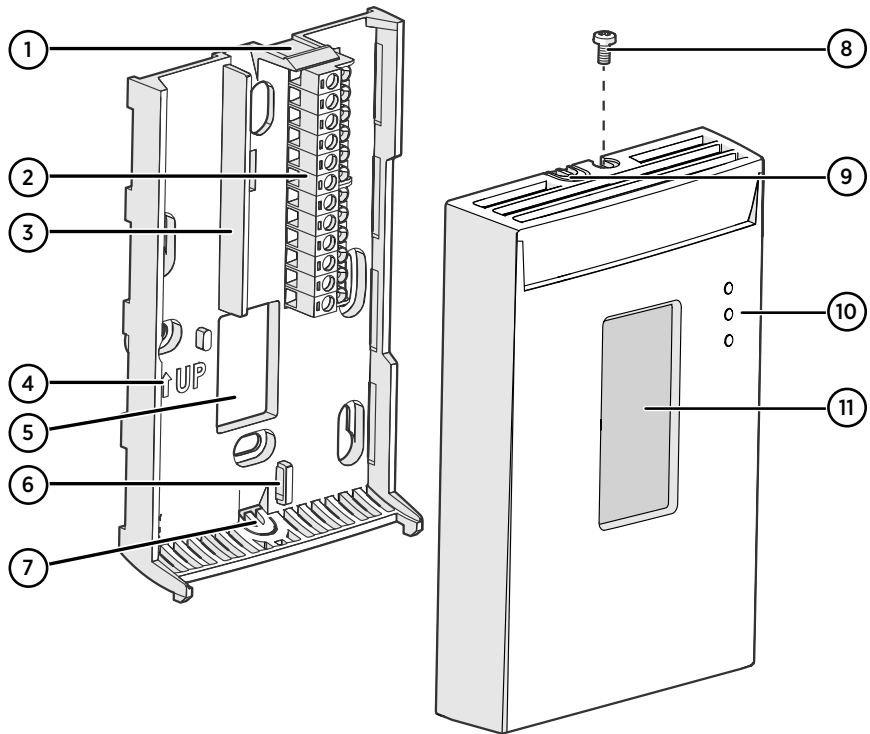

Figure 1 GMW80 series transmitter parts

- 1 Opening tab
- 2 Screw terminals. The wiring information is marked on the mounting base next to the terminals.
- 3 Barrier to prevent the cable from being routed below the GM10 measurement module. The area to avoid is marked **NO CABLES** on the mounting base.
- 4 Orientation arrow. Should point up after mounting base has been installed.
- 5 Opening for cable when wiring from behind (recommended)
- 6 Place for cable tie (optional, for cable strain relief)
- 7 Breakaway tab for routing the cable from below
- 8 Locking screw. Supplied with the transmitter.
- 9 Breakaway tab for routing the cable from above
- 10 CO<sub>2</sub> level indicator LEDs (on models with the letter A) or relay indicator LED (on models with the letter S)
- 11 Display (on models with the letter D)

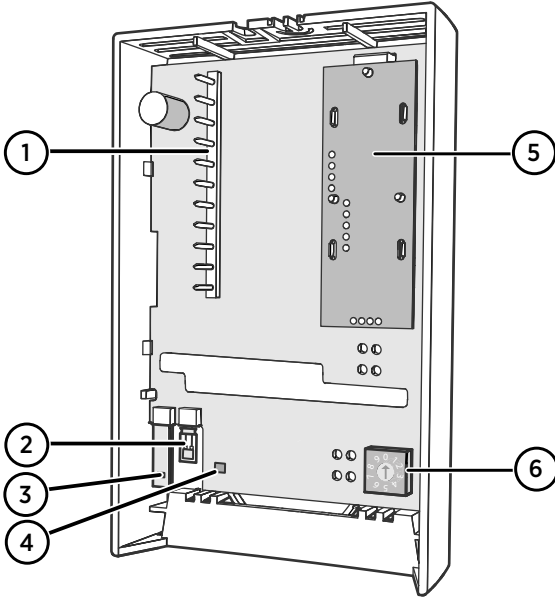

Figure 2 GMW80 series component board parts

- 1 Pins connecting the transmitter cover to the screw terminals when the transmitter cover is in place
- 2 Vaisala INTERCAP® humidity sensor (on models with the letter R)
- 3 Pt1000 temperature sensor for passive temperature measurement (on models with the letter P)
- 4 Active temperature sensor
- 5 GM10 carbon dioxide measurement module
- 6 Rotary switch for relay setpoint (on models with the letter S)

### 2.1.2 GMW87 and GMW88 transmitter parts

The enclosure of the IP64-rated GMW87 and GMW88 transmitter models differs from the other GMW80 transmitter models. In GMW87 and GMW88, the screw terminal block is located on the cover of the enclosure instead of the mounting base. Wires are led into the enclosure either through a cable gland on the bottom of the mounting base or a sealed lead-through at the back. The enclosure is opened and closed with 4 screws instead of the opening tab used in other models.

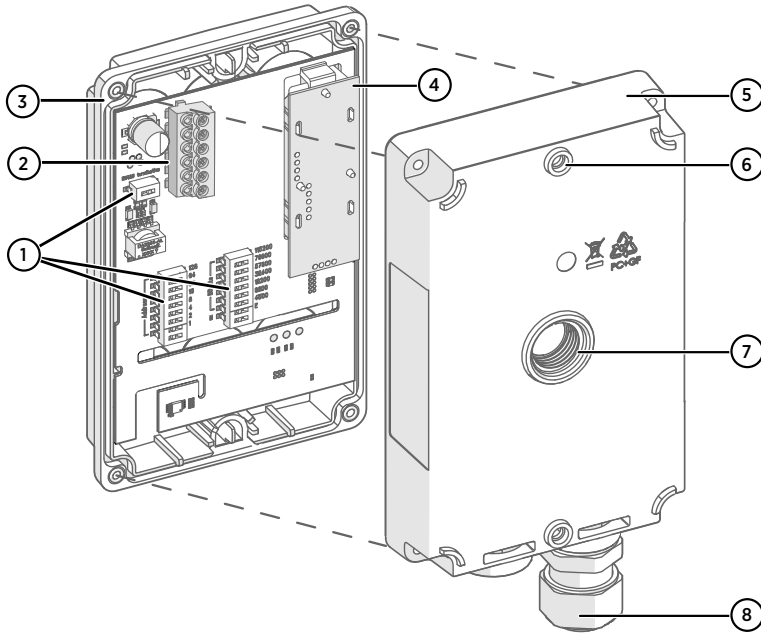

Figure 3 GMW87 transmitter parts

- 1 DIP switches for Modbus settings
- 2 Screw terminals. The screw terminal block is detachable for easy installation.
- 3 Transmitter cover with captive screws (4 pcs)
- 4 GM10 carbon dioxide measurement module
- 5 Mounting base
- 6 Screw holes for mounting on top and bottom of mounting base (2 screws, Ø 3.5 mm)
- 7 Alternative lead-through for wiring through the back (break seal, transfer cable gland here and seal cable gland hole on bottom of transmitter)
- 8 Cable gland for leading the input/output cable (Ø 4 ... 8 mm) inside the enclosure

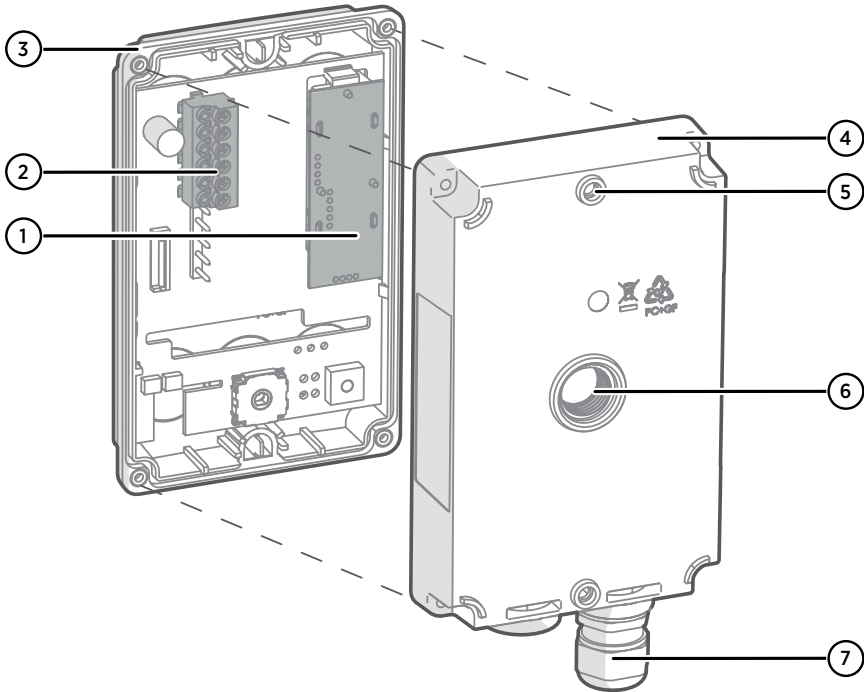

Figure 4 GMW88 transmitter parts

- 1 GM10 carbon dioxide measurement module
- 2 Screw terminals. The wiring information is printed on a label on the mounting base.
- 3 Transmitter cover with captive screws (4 pcs)
- 4 Mounting base
- 5 Screw holes for mounting on top and bottom of mounting base (2 screws, Ø 3.5 mm)
- 6 Alternative lead-through for wiring through the back (break seal, transfer cable gland here and seal cable gland hole on bottom of transmitter)
- 7 Cable gland for leading the input/output cable (Ø 4 ... 8 mm) inside the enclosure

**More information**

- [Installing GMW87 and GMW88 \(page 26\)](#)
- [Dimensions \(page 47\)](#)

## 2.2 Display

GMW80 series transmitters with the letter **D** in the model name (for example, GMW83D) are equipped with a display.

## 2.2.1 Startup screens

When a GMW80 series transmitter with a display is powered on, it shows a sequence of information screens. The screens are shown for a few seconds each.

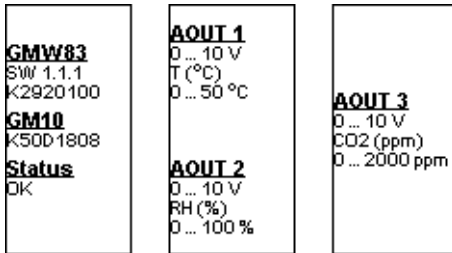

Figure 5 Example startup screens

The first screen shows the following information:

- Transmitter model, software version, and serial number.
- Serial number of the connected GM10 CO<sub>2</sub> measurement module. If the module is disconnected, no serial number is shown.
- Transmitter status: OK or ERROR. If the status is ERROR, the cause of the error will be shown on the measurement screen after the startup is completed.

The following screen(s) show the configuration of the active analog outputs:

- Output type (for example, 0 ... 10 V).
- Output parameter and unit (for example, CO<sub>2</sub> (ppm)).
- Output scaling (for example, 0 ... 2000 ppm).

## 2.2.2 Measurement screen

After the startup screens the transmitter shows the measurement screen. It shows the measured parameters and an air quality indicator based on the current CO<sub>2</sub> level.

- **Good** air quality: 0 ... 800 ppm CO<sub>2</sub>
- **Fair** air quality: 800 ... 1200 ppm CO<sub>2</sub>
- **Poor** air quality: >1200 ppm CO<sub>2</sub>

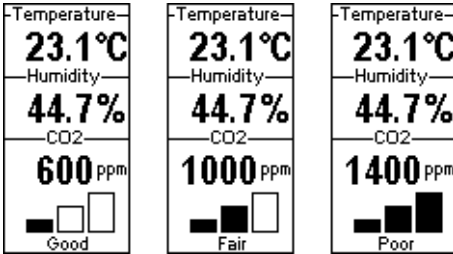

Figure 6 Example measurement screens

Note that temperature measurement data is displayed in Celsius scale only.

### 2.2.3 Error messages

If there is a problem with measurement, affected readings are replaced with stars. The alarm indicator and an error message will also appear on the screen. If more than one error is active, the display will cycle through the errors, showing each error for a few seconds.

For a list of possible errors and their causes, see [Solving typical problems \(page 39\)](#).

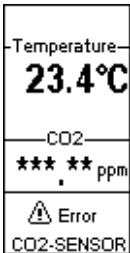

Figure 7 Example error message on display



## 2.3 Relay

Transmitter model GMW84S has one SPST-NO relay (max. 50 VDC / 50 VAC, 500 mA) that is activated when the measured CO<sub>2</sub> level rises above the setpoint. When the relay is active (contact is closed), a green LED is lit on the transmitter cover.

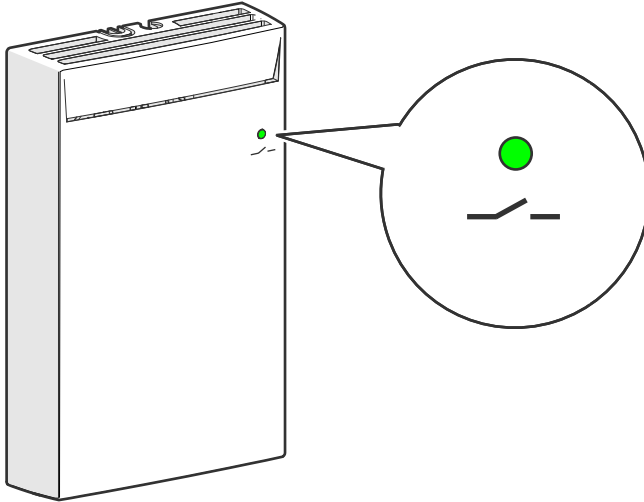

Figure 8 Relay indicator LED on GMW84S

Relay setpoint is set using a rotary switch on the component board. Use a small flat head screwdriver to turn the switch. The switch has ten positions with predefined setpoints.



Figure 9 Rotary switch

Table 4 Relay setpoints

Switch position	Setpoint in ppm CO <sub>2</sub>
0	600 ppm (default)
1	700 ppm
2	800 ppm

Switch position	Setpoint in ppm CO <sub>2</sub>
3	900 ppm
4	1000 ppm
5	1200 ppm
6	1400 ppm
7	1600 ppm
8	1800 ppm
9	2000 ppm

A hysteresis of 50 ppm is applied to prevent the relay from switching back and forth when the measured value is near the setpoint value. The relay is activated/deactivated when the measured CO<sub>2</sub> value passes the setpoint, plus/minus 50 ppm.



For example, consider a transmitter that has the relay setpoint set to 1000 ppm CO<sub>2</sub>. As the measured CO<sub>2</sub> value rises, the relay is activated at 1051 ppm. The relay remains activated until the measured value falls to 949 ppm.

## 2.4 CO<sub>2</sub> level indicator LEDs

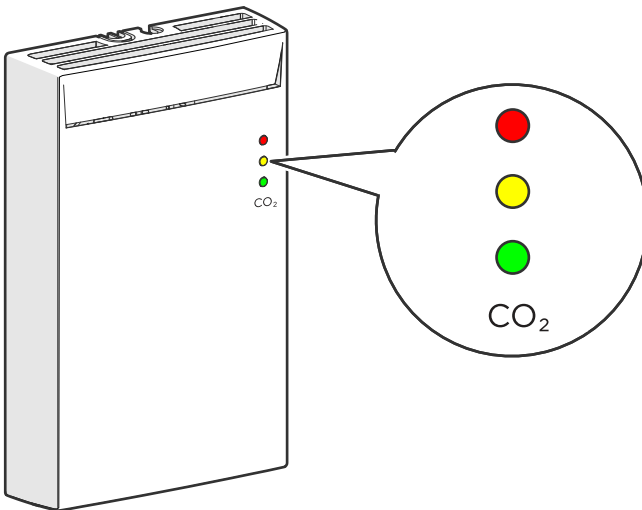

Figure 10 CO<sub>2</sub> level indicator LEDs on model GMW83A

Transmitter model GMW83A has indicator LEDs for the measured CO<sub>2</sub> level on the front cover. The LEDs provide a visual indication of the measured CO<sub>2</sub> level to the occupant of the monitored space.

The LEDs are lit as follows:

- Red LED (top): lit between 1200 ... 2000 ppm CO<sub>2</sub>, blinking > 2000 ppm CO<sub>2</sub>.
- Yellow LED (center): lit between 800 ... 1200 ppm CO<sub>2</sub>.
- Green LED (bottom): lit between 0 ... 800 ppm CO<sub>2</sub>.

## 2.5 Analog output overrange behavior

Analog outputs of the GMW80 series transmitters have a defined behavior when the values measured by the transmitter are outside the scaled analog output range.

- At the top end of the output range, the output is clipped to the maximum value of the output. This means that even if the measured parameter rises, the value does not change anymore.
- At the low end of the output range, the output stays at the minimum value when the measured parameter falls below the scaled range.
- The output is eventually set to the error state if the measured parameter is far enough from the scaled output range. The exact limits for this behavior are parameter dependent; see the figures below.

For more information on the error state, see [Error state \(page 42\)](#).

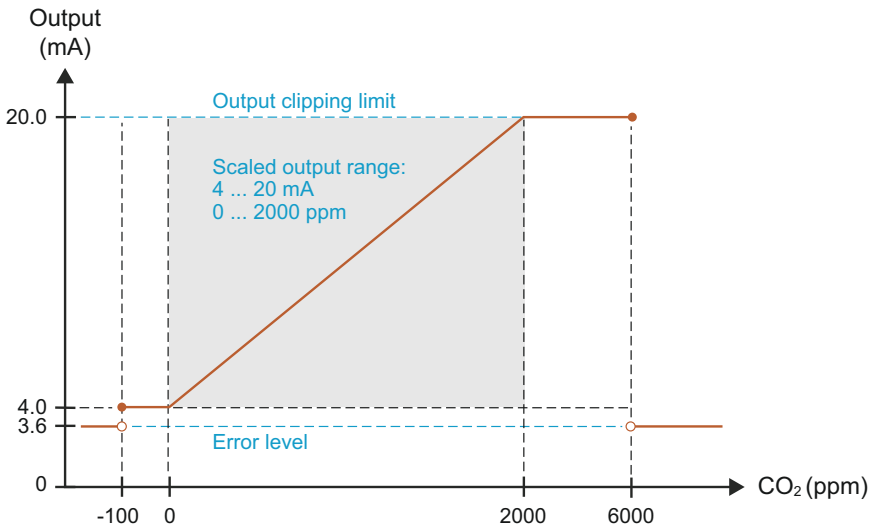

Figure 11 Overage behavior of CO<sub>2</sub> measurement with 4 ... 20 mA output

Negative ppm values cannot physically exist but the behavior of the output is defined to account for cases where a low CO<sub>2</sub> reading, combined with sensor drift, could cause a negative result.

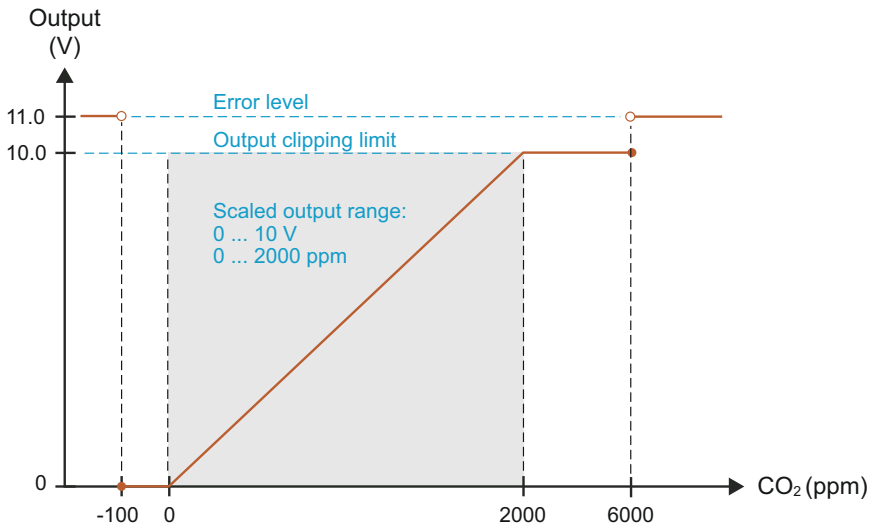

Figure 12 Overrange behavior of CO<sub>2</sub> measurement with 0 ... 10 V output

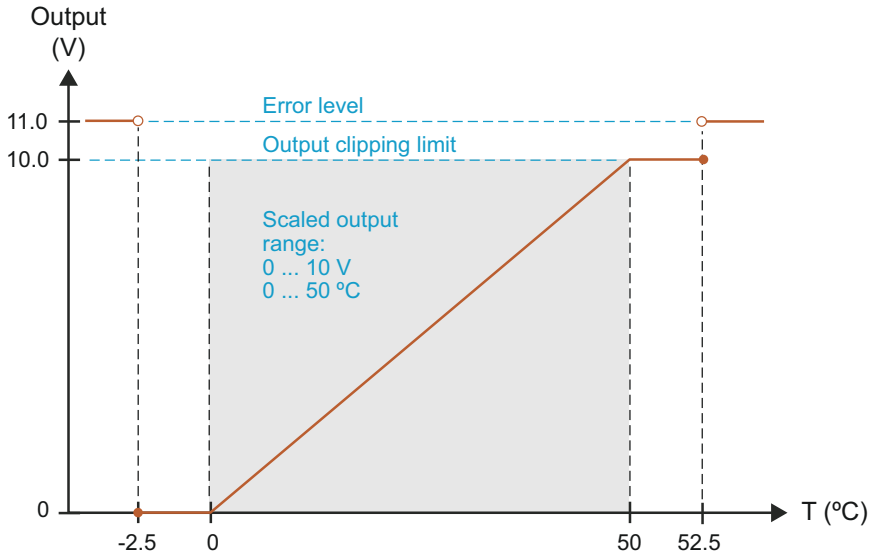

Figure 13 Overrange behavior of active temperature measurement

Passive temperature measurement (reading the Pt1000 resistor) is not affected by the overrange behavior or the error state.

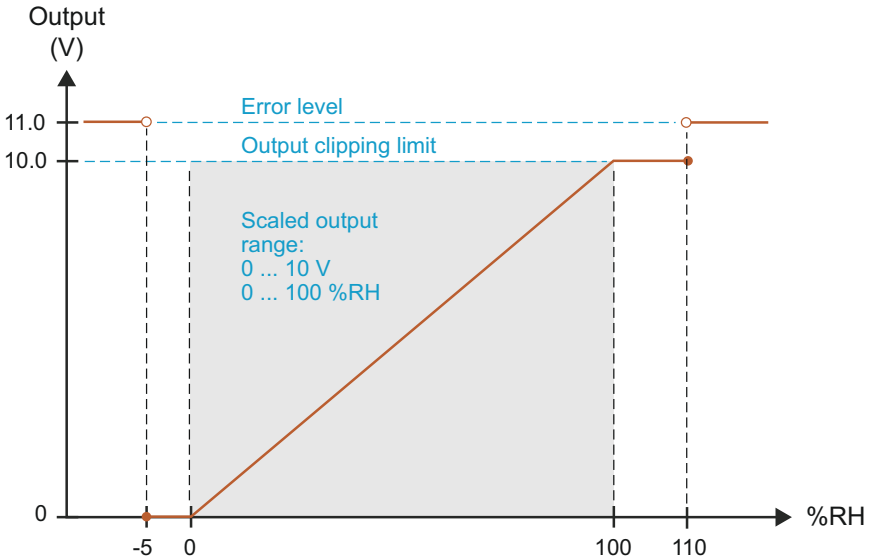

Figure 14 Overrange behavior of relative humidity measurement

The transmitter can measure humidities in excess of 100 %RH if the sensor element becomes wet due to condensation.

## 2.6 Safety

The GMW80 series transmitter delivered to you has been tested for safety and approved as shipped from the factory. Note the following precautions:



**WARNING!** Make sure that you prepare or connect only de-energized wires.



**CAUTION!** Do not modify the unit or use it in ways not described in the documentation. Improper modification or use may lead to safety hazards, equipment damage, failure to perform according to specification, or decreased equipment lifetime.



**CAUTION!** Electrostatic Discharge (ESD) can cause immediate or latent damage to electronic circuits. Avoid touching exposed component contacts during installation and maintenance.

## 2.7 Regulatory compliance

GMW80 series complies with the following regulations:

- RoHS Directive (2011/65/EU)
- EMC Directive (2014/30/EU)
- European Union CE marking

The conformity is declared with using the following standards:

- EN 50581: Technical documentation for the assessment of electrical and electronic products with respect to the restriction of hazardous substances.
- EN 61326-1: Electrical equipment for measurement, control, and laboratory use – EMC requirements – Immunity test requirements for equipment intended to be used in an industrial electromagnetic environment.
- EN 55032: Information technology equipment – Radio disturbance characteristics – Limits and methods of measurement.

## 3. Installation

### 3.1 Selecting location

Select a location that represents well the area of interest. Interior walls and columns are typically suitable locations. The installation height should be 1.2 ... 1.8 m (4 ... 6 ft).

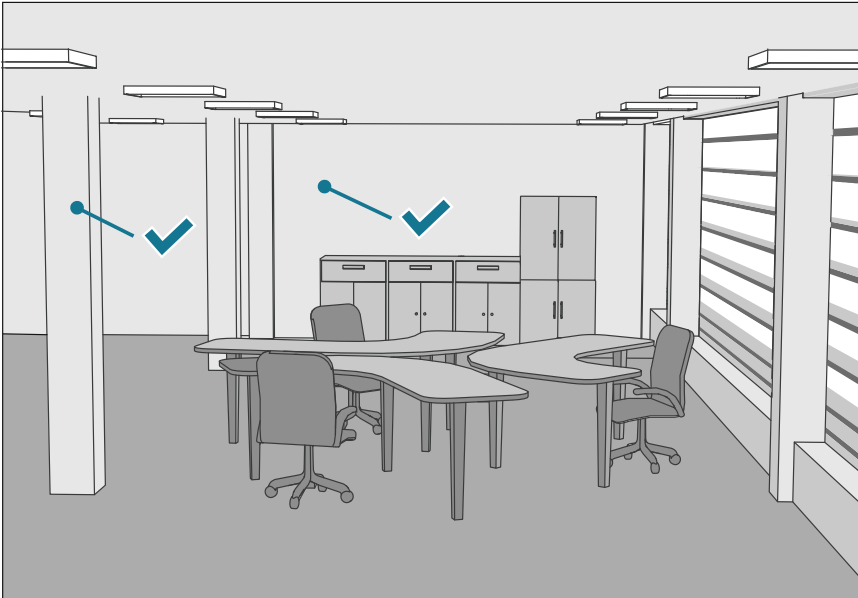

Figure 15 Examples of good installation locations



Seal the cable opening when bringing a cable through the wall. The hole will supply air from outside the room into the transmitter and affect the measurement readings. For example, fresh concrete binds CO<sub>2</sub> and may cause low readings, especially in new buildings.

Avoid installing in the following locations:

- Near doors or windows.
- Near heat and moisture sources.
- In direct sunlight.
- In locations that are blocked by furniture.
- Close to the discharge of supply air ducts.
- On the floor or the ceiling.



- On points that experience excessive vibration.

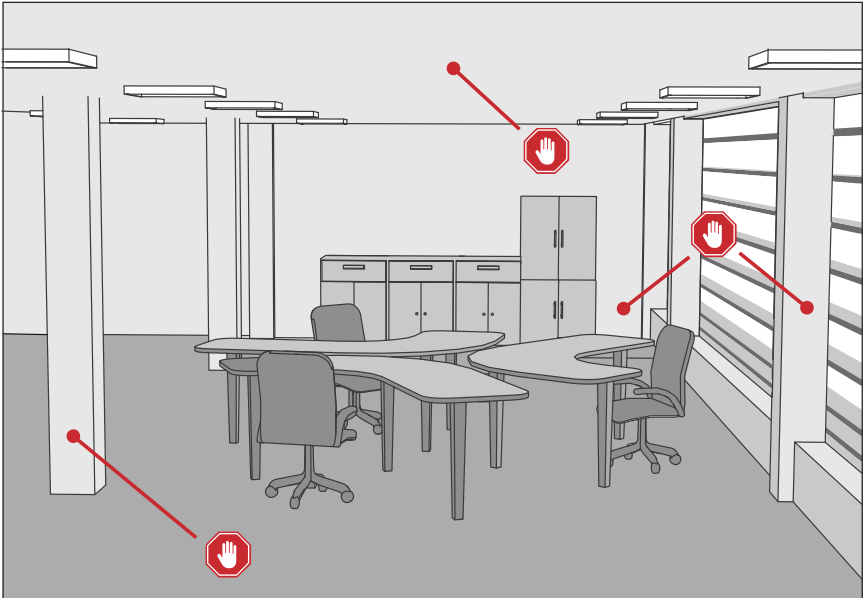
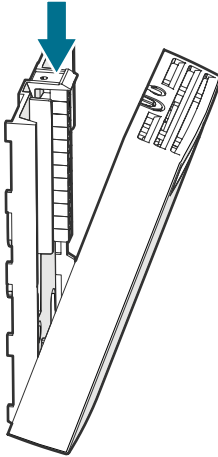

Figure 16 Examples of unsuitable installation locations

## 3.2 Opening and closing the transmitter

GMW80 series transmitters are delivered from the factory with a pull tab that makes it easy to open the transmitter for installation. Note that the GMW87 and GMW88 models are opened and closed with 4 screws instead of an opening tab. See [GMW87 and GMW88 transmitter parts](#) (page 10).

- ▶ 1. To open the transmitter after it has been installed:
  - a. Loosen the locking screw if it has been installed.
  - b. Use a flat screwdriver to push down the tab that holds the transmitter cover and mounting base together, and pull the top of the transmitter cover away from the mounting base.



**CAUTION!** Be careful when opening the transmitter:

- Pushing down too hard can break off the opening tab.
- Inserting the screwdriver too far into the transmitter enclosure may damage transmitter components.

2. To close the transmitter:
  - a. Align the bottom of the transmitter cover with the bottom of the mounting base.
  - b. Tilt the top of the transmitter cover forward until the tab catches with an audible snap. Note that closing the transmitter starts it up if power is supplied to the screw terminals.
  - c. Pull on the cover gently to make sure it is properly closed and not loose.
  - d. Attach the locking screw if desired.

### 3.3 Installing the mounting base

GMW80 series transmitters are designed to be installed on a mounting box or directly to a wall surface.

- ▶ 1. Make sure the orientation arrow on the mounting base points up. Proper orientation is important: air must flow through the vents on the bottom and top.

- Use the mounting holes to attach the mounting base securely. Use at least two screws (not included). The mounting holes are suitable for the most common European, American, and Asian mounting boxes. The mounting base can be twisted on to pre-mounted screws.



**CAUTION!** To avoid damaging the component board when you close the enclosure, make sure the screw heads do not project out of the mounting holes.

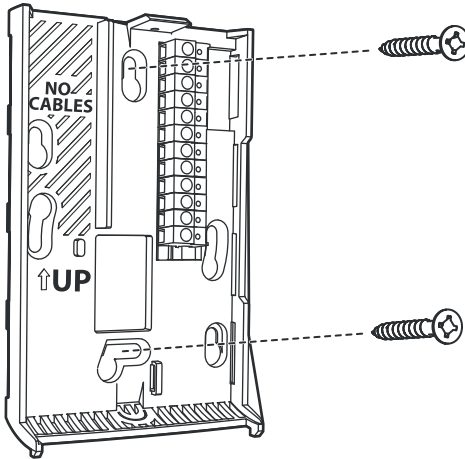

**CAUTION!** Mounting bases are tailored to the individual transmitter at the factory. If you attach several mounting bases before connecting the transmitters, store the transmitters in their original shipping boxes, so that you can match the serial number on the mounting base to the serial number on the shipping box.



The mounting base of the GMW87 and GMW88 models differs from other GMW80 series models. See [Installing GMW87 and GMW88 \(page 26\)](#).

### 3.4 Installing GMW87 and GMW88

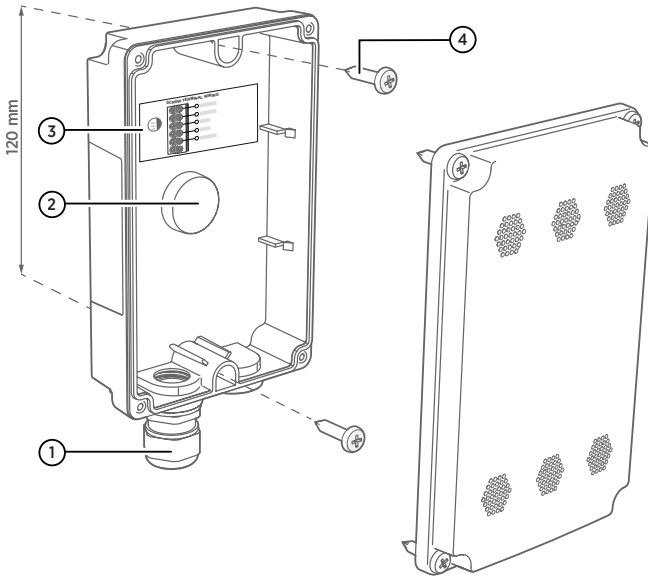

Figure 17 Mounting GMW87 and GMW88

- 1 Cable gland for leading the input/output cable ( $\varnothing$  4 ... 8 mm) inside the enclosure
- 2 Alternative lead-through for wiring through the back (break seal and transfer cable gland to the threads on this lead-through)
- 3 Wiring instructions label
- 4 Mounting screws (2 pcs,  $\varnothing$  3.5 mm, head  $\varnothing \leq 8$  mm)



For the location of the screw terminal block and the GM10 module, see [GMW87 and GMW88 transmitter parts \(page 10\)](#).

- ▶ 1. Open the transmitter cover (4 screws) and use 2 mounting screws ( $\varnothing$  3.5 mm) to attach the mounting base to the installation surface. Point the cable gland straight down.
2. Route the input/output cable through the cable gland.



If you use the alternative lead-through on the back of the transmitter, seal the hole on the bottom of the transmitter after removing the cable gland.

3. For ease of installation, you can disconnect the screw terminal block by pulling it out from the component board.
4. Attach wiring to the screw terminals as shown on the wiring instructions label. See also [Wiring GMW87 \(page 33\)](#) and [Wiring GMW88 \(page 33\)](#).
5. If you disconnected the screw terminal block, plug it back in. Make sure it is positioned correctly.
6. Push down gently on the GM10 module. The module should be straight and firmly connected.
7. Tighten the cable gland and close the transmitter cover (4 screws).

## 3.5 Wiring



**CAUTION!** With passive Pt1000 sensors the length of the cables affects the accuracy of the measurement reading, since the connection is susceptible to electrical interference. Vaisala recommends using shielded twisted pair cables, with the shield grounded. When using a shielded cable, do not connect the shield to the transmitter.

Connect the wiring to the screw terminals on the mounting base. The terminal assignments are marked next to the screw terminals. Do not connect wiring to unmarked terminals.

Note that the analog signal ground terminal is internally connected to the power supply ground terminal.

Maximum wire size is 2 mm<sup>2</sup> (AWG14). Route the cable through the hole in the mounting base if possible.



The GMW87 and GMW88 transmitters are wired either through a cable gland on the bottom of the transmitter or an alternative lead-through on the back of the transmitter. See [GMW87 and GMW88 transmitter parts \(page 10\)](#).

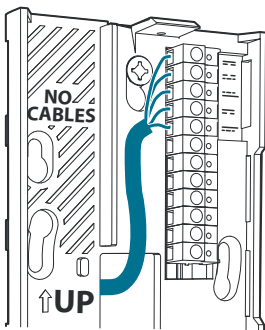

Figure 18 Routing the cable from behind (GMW83, GMW84, and GMW86 models)



**WARNING!** Connect only de-energized wires.



**CAUTION!** Do not route the cable through the area marked **NO CABLES** on the mounting base. That space is taken up by the CO<sub>2</sub> measurement module when the transmitter cover is attached.

You can also bring the cable to the housing from above or below, but you have to break off the small plastic tab that covers the hole on top or bottom of the housing.

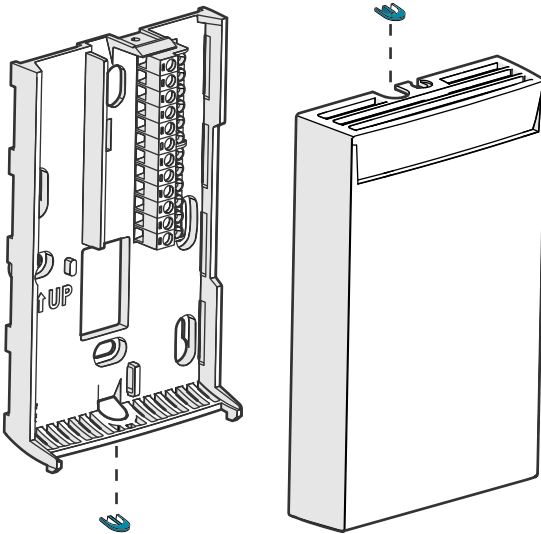

Figure 19 Locations of the breakaway tabs

When wiring from below, you can secure the cable with a cable tie to provide strain relief.

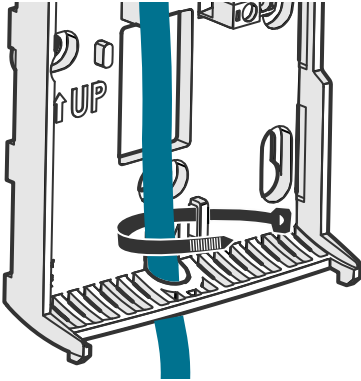

Figure 20 Wiring from below with cable tie strain relief

After completing the wiring, connect the transmitter body over the mounting base. Note that mounting bases are model-specific.

### 3.5.1 Wiring GMW83, GMW83D, and GMW83A

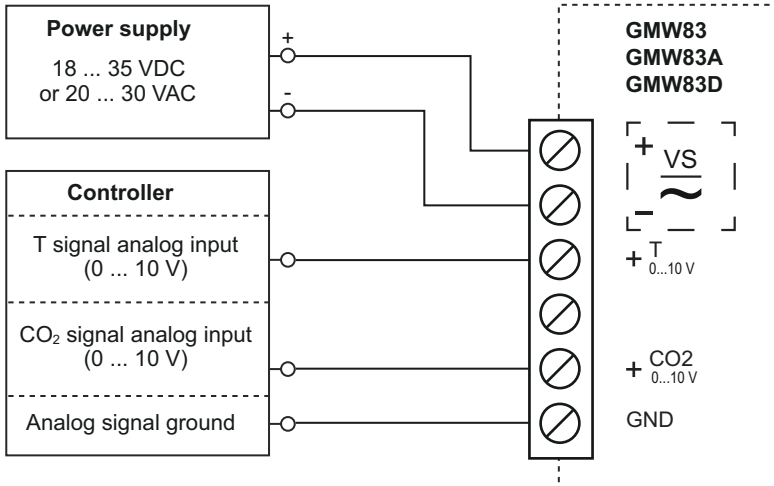

Figure 21 Wiring for GMW83, GMW83D, and GMW83A

### 3.5.2 Wiring GMW83RP and GMW83DRP

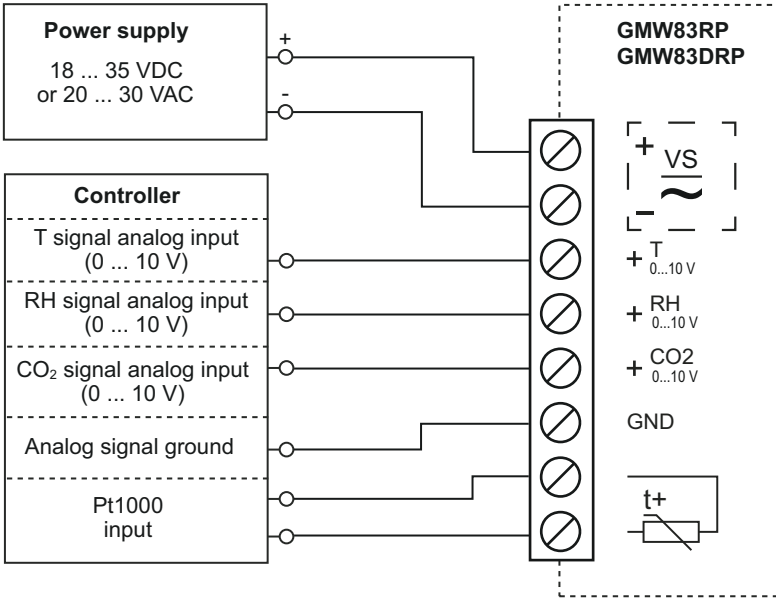

Figure 22 Wiring for GMW83RP and GMW83DRP

### 3.5.3 Wiring GMW84

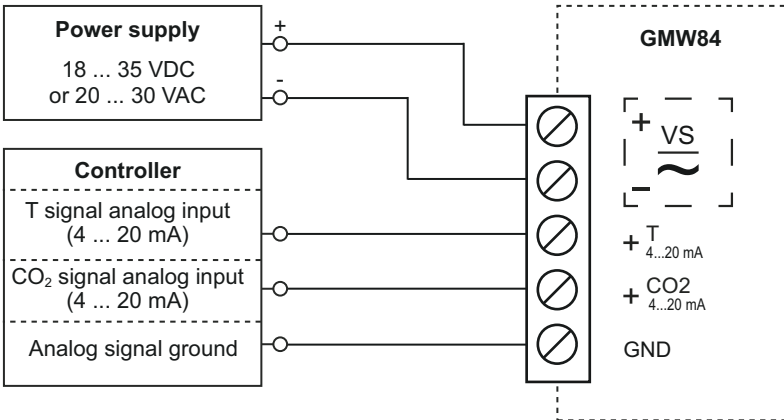

Figure 23 Wiring for GMW84



### 3.5.4 Wiring GMW84S

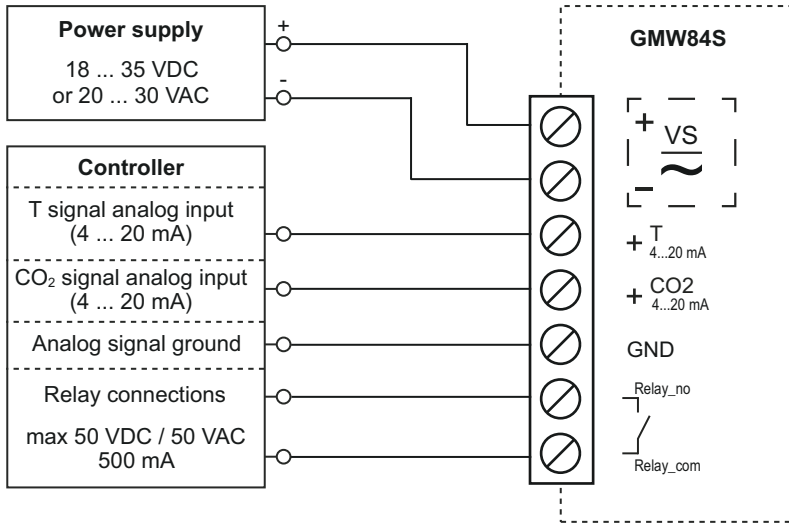

Figure 24 Wiring for GMW84S

To change the setpoint of the relay, turn the rotary switch on the component board. See [Relay \(page 15\)](#).

### 3.5.5 Wiring GMW86P

GMW86P has two outputs for the CO<sub>2</sub> signal: 4 ... 20 mA and 0 ... 10 V. You can use both outputs simultaneously but typically only one of them is needed. Note that they share a common minus terminal.

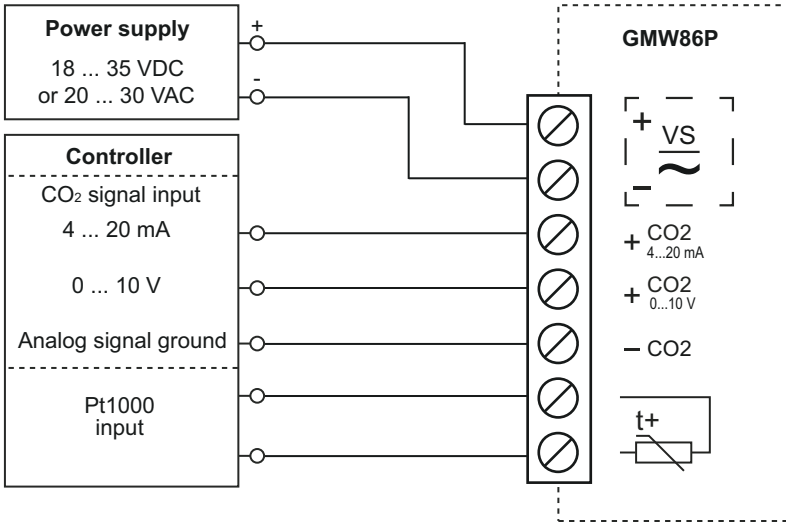

Figure 25 Wiring for GMW86P

### 3.5.6 Wiring GMW87

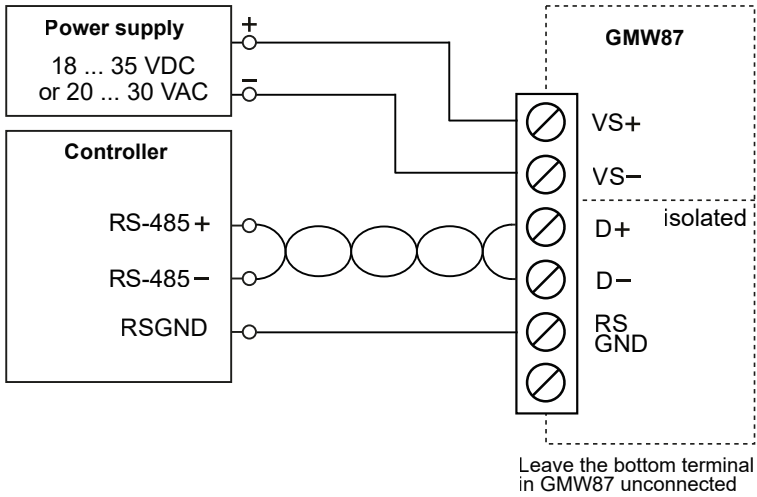

Figure 26 Wiring for GMW87

### 3.5.7 Wiring GMW88

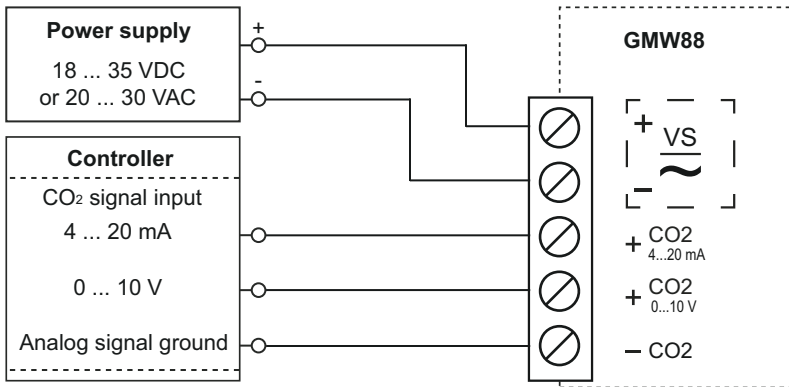

Figure 27 Wiring for GMW88

# 4. Modbus communication

The Modbus variant used in GMW87 is Modbus RTU. For a list of the Modbus registers available in GMW87, see [Modbus registers \(page 50\)](#).

You can use up to 8 transmitters on the same RS-485 line. You must configure each transmitter on the line to have a different Modbus address.

**i** Before taking the transmitter into use, check that the Modbus device address, bit rate setting, and parity setting match the settings in your system. The number of stop bits is not significant. The device supports automatically both 1 and 2 stop bits.

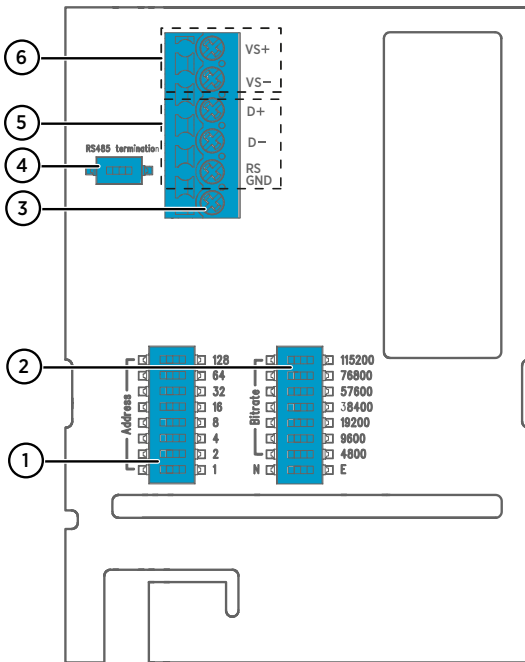

Figure 28 GMW87 component board with DIP switches and screw terminals

- 1 DIP switches for setting the GMW87 Modbus device address
- 2 DIP switches for selecting Modbus communication bit rate and parity (N/E)
- 3 Screw terminal not used in GMW87
- 4 DIP switch for 120 Ω RS-485 bus termination. Switch RS-485 bus termination **ON** only on the last device of the wiring if there is no separate terminator on the bus.
- 5 RS-485 (Modbus) screw terminals
- 6 Power supply input (18 ... 35 VDC or 20 ... 30 VAC) screw terminals

Make selections with the DIP switches by sliding the DIP switch to the right (**ON**). Keep the other DIP switches on the left position (**OFF**).

## Setting Modbus device address with DIP switches

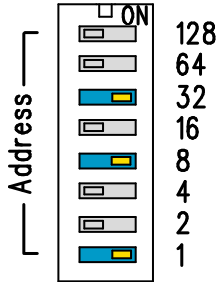

Figure 29 Modbus device address DIP switch example

DIP switches 32, 8, and 1 set to ON

The Modbus device address is encoded in eight bit binary form, with each numbered switch representing a single bit. This example shows address 41 selected: DIP switches 32, 8, and 1 (decimal: 41, binary: 00101001) are set to **ON**.

## Modbus device address ranges

The Modbus device address range for the transmitter is 1 ... 247. Up to 255 is possible, but non-standard.

If no address is selected (0), the device is off-line and will not respond to any Modbus requests.

## 5. Maintenance

### 5.1 Cleaning

The body of the transmitter can be cleaned by wiping with a moistened lint-free cloth. Do not use cleaning agents or solvents, or blow pressurized air into the transmitter housing.



If you suspect the CO<sub>2</sub> measurement module is dirty, do not attempt to open it. Instead, replace it with a new part. For item codes of spare parts, see [Spare parts and accessories \(page 46\)](#).

### 5.2 Replacing the CO<sub>2</sub> measurement module (GM10)



- GM10 spare part module (Vaisala item code GM10SP80)
- Flat head screwdriver (for opening the transmitter)

To replace the module:

- ▶ 1. Disconnect the transmitter body from the mounting base.
2. Locate the GM10 module on the transmitter. The module is a separate component board with a golden cuvette that contains the CARBOCAP® sensor. The module is connected to the main transmitter board with a connector, and held in place by a plastic clip on the other side. See [Figure 2 \(page 10\)](#).
3. Disconnect the module by carefully lifting the module from the connector side.

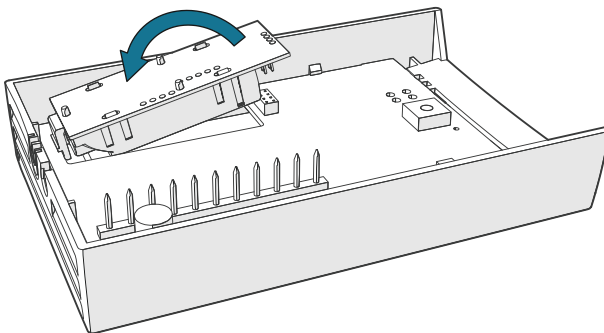

Figure 30 Disconnecting the GM10 module

4. Take the new GM10 module and place it in the hole for the module so that the plastic clip meets the component board. Then lower the connector end of the module.
5. Push down on the module to secure the connector.
6. Reconnect the transmitter to the mounting base.
7. Check the output of the transmitter (or the display if included on the model) to verify that the CO<sub>2</sub> measurement is working normally and is not in the error state. For more information on the error state, see [Error state \(page 42\)](#).

## 5.3 Replacing the INTERCAP humidity sensor



- INTERCAP® sensor (Vaisala item code 15778HM)
- Flat head screwdriver (for opening the transmitter)



**CAUTION!** To avoid contaminating or damaging the sensor:

- Handle the sensor by its plastic frame.
- Do not touch the sensor surface in the middle.
- Wear lint-free ESD gloves.

To replace the sensor:

- ▶ 1. Disconnect the transmitter body from the mounting base.
2. Locate the INTERCAP® sensor on the component board. See [Figure 2 \(page 10\)](#).
3. Disconnect the old INTERCAP® sensor by pulling it straight out of its socket.

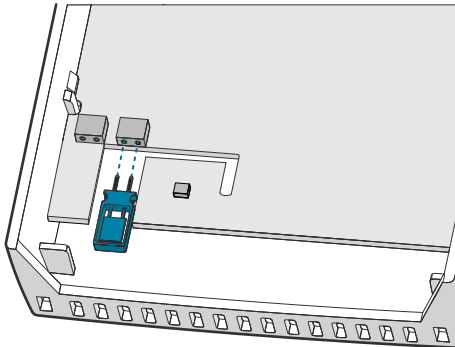

4. Insert the new INTERCAP® sensor in the socket.
5. Reconnect the transmitter to the mounting base.

6. Check the output of the transmitter (or the display if included on the model) to verify that the humidity measurement is working normally and the transmitter is not in the error state. For more information on the error state, see [Error state \(page 42\)](#).



## 6. Troubleshooting

### 6.1 Solving typical problems

If you experience problems with GMW80 series transmitters, first see the following tables (for analog output and Modbus models) concerning the behavior and error indications of the transmitter. If you cannot locate the source of the error and return the transmitter to operational state, contact Vaisala. See [Technical support \(page 55\)](#).

Table 5 Troubleshooting table, transmitters with analog output

Problem or message	Possible cause	Solution
Analog output reading is unchanging and appears incorrect.	Transmitter has set the analog output to the error level (3.6 mA or 11 V) because the transmitter is in the error state.	Determine what has caused the error state and remove the cause.  For a description of the error state and its possible causes, see <a href="#">Error state (page 42)</a> .
Temperature reading is too high.	Transmitter is installed in an unsuitable location, for example, near a heat source or in sunlight.	Relocate transmitter. See <a href="#">Selecting location (page 22)</a> .
	Transmitter is installed in improper orientation.	Reinstall transmitter with the arrow on the mounting base pointing up.
	Unsuitable operating environment.	Verify that the operating environment is within specified operating limits.
CO <sub>2</sub> reading is too high.	Source of CO <sub>2</sub> near the transmitter.	<ul style="list-style-type: none"> <li>Use a portable instrument to verify the CO<sub>2</sub> reading at the installation location. Avoid breathing on the instruments while checking.</li> <li>Check for sources of CO<sub>2</sub> in the measured area, such as people working right next to the transmitter.</li> </ul>
	CO <sub>2</sub> measurement module must be replaced.	See <a href="#">Replacing the CO<sub>2</sub> measurement module (GM10) (page 36)</a> .

Problem or message	Possible cause	Solution
CO <sub>2</sub> reading is too low.	The measured area contains materials that bind CO <sub>2</sub> (such as fresh concrete), producing a low-CO <sub>2</sub> environment.	<ul style="list-style-type: none"> <li>• Use a portable instrument to verify the CO<sub>2</sub> reading at the installation location. Avoid breathing on the instruments while checking.</li> <li>• Check if the transmitter is installed on a mounting box that supplies air from inside the wall into the transmitter. If yes, seal the opening that supplies the air.</li> </ul>
	CO <sub>2</sub> measurement module must be replaced.	See <a href="#">Replacing the CO 2 measurement module (GM10) (page 36)</a> .
Relay is always activated.	Relay setpoint set too low.	Adjust the relay setpoint. See <a href="#">Relay (page 15)</a> .
Error text on display: <b>CO2-SENSOR</b>	GM10 module disconnected.	<p>Open the transmitter and check if the GM10 module is installed securely. See <a href="#">Figure 2 (page 10)</a>.</p> <ul style="list-style-type: none"> <li>• If the module is loose or entirely disconnected, reinstall it as instructed in <a href="#">Replacing the CO 2 measurement module (GM10) (page 36)</a>.</li> <li>• If the GM10 module appears to be installed but the problem persists, disconnect and reconnect the module carefully.</li> </ul>
	CO <sub>2</sub> measurement module must be replaced.	Replace the GM10 module with a verified working module.
	CO <sub>2</sub> reading over 6000 ppm.	<ul style="list-style-type: none"> <li>• Use a portable instrument to verify the CO<sub>2</sub> reading at the installation location. Avoid breathing on the instruments while checking.</li> <li>• Check for sources of CO<sub>2</sub> in the measured area, such as people working right next to the transmitter.</li> </ul>

Problem or message	Possible cause	Solution
Error text on display: <b>RH-SENSOR</b>	Humidity sensor disconnected.	Open the transmitter and check the condition of the humidity sensor. See <a href="#">Figure 2 (page 10)</a> .  <ul style="list-style-type: none"> <li>• If the sensor is missing or damaged, replace it. See <a href="#">Replacing the INTERCAP humidity sensor (page 37)</a>.</li> <li>• If the sensor is wet, wait for it to dry or dry it very gently with clean instrument air.</li> </ul>
	Humidity sensor damaged.	
	Humidity sensor wet.	
Error text on display: <b>T-SENSOR</b>	Temperature reading is outside the scaled output range.	<ul style="list-style-type: none"> <li>• Verify the ambient temperature with a portable instrument.</li> <li>• See <a href="#">Analog output overrange behavior (page 17)</a>.</li> </ul>
	Temperature sensor damaged.	Open the transmitter and check if the active temperature sensor on the component board has been damaged. See <a href="#">Figure 2 (page 10)</a> .
Error text on display: <b>INTERNAL</b>	Problem with transmitter software.	<ul style="list-style-type: none"> <li>• Restart the transmitter.</li> <li>• If the error persists, contact Vaisala support.</li> </ul>

Table 6 Troubleshooting table, transmitter model GMW87

Problem	Solution
The device is not responding	<ul style="list-style-type: none"> <li>• Power-cycle the transmitter by disconnecting the screw terminal block</li> <li>• Check power supply voltage</li> <li>• Check wiring, including RS-485 bus polarity</li> <li>• Check that RS GND is connected between the transmitter and the receiver</li> <li>• Compare the DIP switch settings to your Modbus host settings</li> <li>• Check that RS-485 termination is enabled only on the last device of the wiring</li> <li>• Alternatively, try operation without RS-485 termination at all</li> </ul>
Unexpected value in Modbus response	<ul style="list-style-type: none"> <li>• Change register number and/or data encoding settings in your Modbus host system</li> </ul>
No measurement result and/or non-zero status code returned	<ul style="list-style-type: none"> <li>• Device is warming up, try again after 20 seconds</li> <li>• Power-cycle the transmitter by disconnecting the screw terminal block</li> <li>• Check that the GM10 module is properly attached</li> <li>• Contact Vaisala for a replacement GM10 module</li> </ul>

## 6.2 Error state

If the transmitter detects a serious hardware or software error, or the measured reading is well outside the scaled range, the analog outputs are set into a defined error level instead of the measured result. The error level depends on the output type:

- For 4 ... 20 mA output, the error level is **3.6 mA**.
- For 0 ... 10 V output, the error level is **11 V**.

If the cause of the error is removed, the transmitter resumes normal operation of analog outputs. Some errors may require a reset of the transmitter to recover.

If the error state is caused by a measurement result being well outside the scaled output range, only affected channels are set to the error state. For more information, see [Analog output overrange behavior \(page 17\)](#).



Examples of situations that may cause the error state:

- The transmitter measures over 6000 ppm CO<sub>2</sub>.
- The CO<sub>2</sub> measurement module (GM10) is disconnected.

## 7. Technical data

### 7.1 Specifications

Table 7 GMW80 models

Model	Measurements	Output
GMW86P	CO <sub>2</sub> +T	Current and voltage output, Pt1000
GMW83RP <sup>1)</sup>	CO <sub>2</sub> +RH+T	Voltage outputs, Pt1000
GMW83DRP <sup>1)</sup>	CO <sub>2</sub> +RH+T	Voltage outputs, Pt1000, Display with metric scale output
GMW83	CO <sub>2</sub> +T	Voltage outputs
GMW83A	CO <sub>2</sub> +T	Voltage outputs, CO <sub>2</sub> indicator LEDs
GMW83D	CO <sub>2</sub> +T	Voltage outputs, Display with metric scale output
GMW84	CO <sub>2</sub> +T	Current output
GMW84S	CO <sub>2</sub> +T	Current output, Relay
GMW87	CO <sub>2</sub>	RS-485 Modbus RTU output
GMW88	CO <sub>2</sub>	Current and voltage output

<sup>1)</sup> Models with calibration certificate available (GMW83RPC/GMW83DRPC).

Table 8 GMW80 measurement performance

Property	Value/Description
<b>Carbon dioxide</b>	
Measurement range	0 ... 2000 ppm 0 ... 5000 ppm (GMW87)
Accuracy:	
at +20 ... +30 °C (+68 ... +86 °F)	±(30 ppm +3 % of reading)
at +10 ... +20 °C (+50 ... +68 °F) and +30 ... +40 °C (+86 ... +104 °F)	±(35 ppm +3.7 % of reading)
at +0 ... +10 °C (+32 ... +50 °F) and +40 ... +50 °C (+104 ... +122 °F)	±(40 ppm +4.8 % of reading)
Stability in typical HVAC applications	±(15 ppm + 2 % of reading) over 5 years
Warm-up time	1 min 10 min for full specification

Property	Value/Description
Response time (63 %)	60 s 7 min (GMW87 and GMW88)
Carbon dioxide sensor	Vaisala CARBOCAP® GM10
<b>Temperature</b>	
Measurement range	0 ... +50 °C (+32 ... +122 °F)
Temperature sensor	On P models: Pt1000 RTD Class F0.15 IEC 60751 For analog outputs: Digital temperature sensor
Accuracy (GMW83 and GMW84):	
at +10 ... +30 °C (+50 ... +86 °F)	±0.5 °C (0.9 °F)
at +0 ... +10 °C (+32 ... +50 °F) and +30 ... 50 °C (+86 ... +122 °F)	±1 °C (1.8 °F)
<b>Humidity</b>	
Measurement range	0 ... 95 %RH
Accuracy at temperature range +10 ... +30 °C (+50 ... +86 °F):	
0 ... 80 %RH	±3 %RH
80 ... 95 %RH	±5 %RH
Accuracy at temperature ranges 0 ... +10 °C (+32 ... +50 °F) and +30 ... +50 °C (+86 ... +122 °F):	
0 ... 95 %RH	±7 %RH
Stability in typical HVAC applications	±2 %RH over 2 years
Product lifetime	> 15 years

Table 9 GMW80 compliance

Property	Value/Description
EMC compatibility	IEC/EN/BS 61326-1, industrial environment
Compliance marks	CE, RCM, WEEE

Table 10 GMW80 operating environment

Property	Value/Description
Operating temperature	0 ... +50 °C (+32 ... +122 °F)
Operating humidity	0 ... 95 %RH Dew point < 30 °C (+86 °F)

Property	Value/Description
Storage temperature	Models without display: -40 ... +70 °C (-40 ... +158 °F) Models with display: -30 ... +70 °C (-22 ... +158 °F)

Table 11 GMW80 inputs and outputs

Property	Value/Description
Supply voltage	18 ... 35 VDC 24 VAC $\pm$ 20 % 50/60 Hz
Max. current consumption at 18 VDC	45 mA 70 mA (GMW84 models)
Max. power consumption at 30 VAC	0.7 W (GMW83 models) 1 W (GMW86 models, GMW87, and GMW88) 1.2 W (GMW84 models)
Digital output (RS-485) (in GMW87 only)	Isolated, supports Modbus RTU protocol <ul style="list-style-type: none"> <li>• Modbus RTU address range: <ul style="list-style-type: none"> <li>• 1 ... 247 (up to 255 possible, non-standard)</li> </ul> </li> <li>• Bit rates: <ul style="list-style-type: none"> <li>• 4800, 9600, 19200, 38400, 57600, 76800, 115200</li> </ul> </li> <li>• Parity: <ul style="list-style-type: none"> <li>• None or Even</li> </ul> </li> <li>• Supports automatically both 1 and 2 stop bits</li> </ul>
Outputs	4 ... 20 mA and/or 0 ... 10 V <sup>1)</sup>
Current loop resistance (4 ... 20 mA)	0 ... 600 $\Omega$
Voltage output load resistance	Min. 10 k $\Omega$
CO <sub>2</sub> output scale	0 ... 2000 ppm
Temperature output scale	0 ... +50 °C (+32 ... +122 °F)
Humidity output scale	0 ... 100 %RH
Passive temperature sensor (P models)	Pt1000 RTD
Temperature setpoint (T models)	10 k $\Omega$ potentiometer
Relay (S models)	1 pc, SPST-NO Max. 50 VDC / 50 VAC, 500 mA

Property	Value/Description
CO <sub>2</sub> indicator LED levels (A model)	Flashing red: > 2000 ppm Red: 1200 ... 2000 ppm Yellow: 800 ... 1200 ppm Green: < 800 ppm

1) Analog outputs are not available in model GMW87.

Table 12 GMW80 mechanical specifications

Property	Value/Description
IP rating	IP30 IP64 (GMW87 and GMW88)
Housing material	ABS/PC UL-V0 approved PC (GMW87 and GMW88)
Housing color	White (RAL9003)
Output connector	Screw terminal
Max. wire size	2 mm <sup>2</sup> (AWG14)
Weight	Plain and LED version: 114 g (4.02 oz) Display version: 124 g (4.37 oz) GMW87 and GMW88: 160 g (5.64 oz)

## 7.2 Spare parts and accessories



Information on spare parts, accessories, and calibration products is available online at [www.vaisala.com](http://www.vaisala.com) and [store.vaisala.com](http://store.vaisala.com).

Item	Item code
CO <sub>2</sub> module	GM10SP80
INTERCAP® sensor	15778HM



## 7.3 Dimensions

All dimensions are in millimeters (mm).

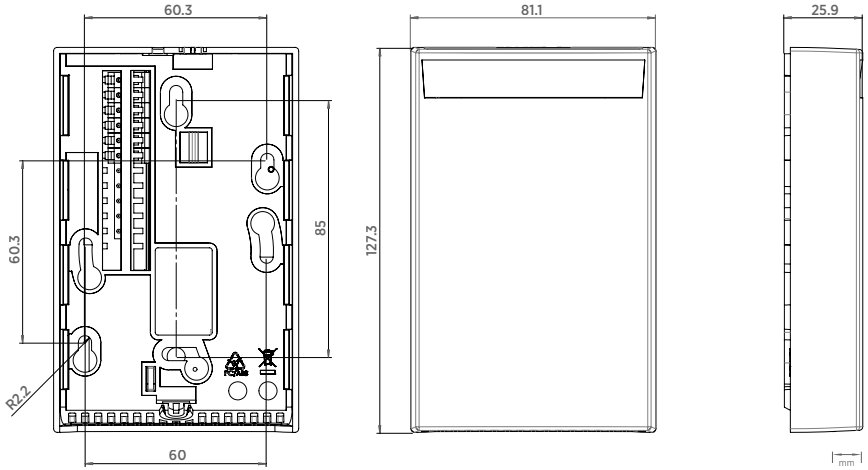

Figure 31 Dimensions for GMW83, GMW83A, GMW83RP, GMW84, GMW84S, and GMW86P

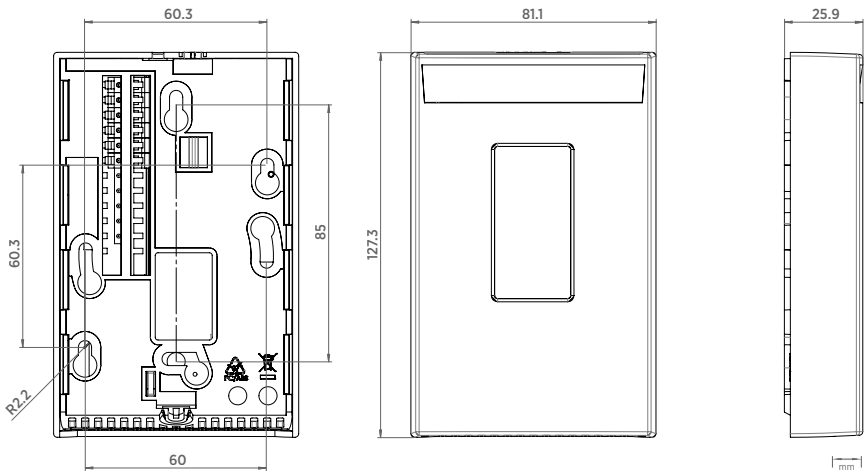

Figure 32 Dimensions for GMW83D and GMW83DRP

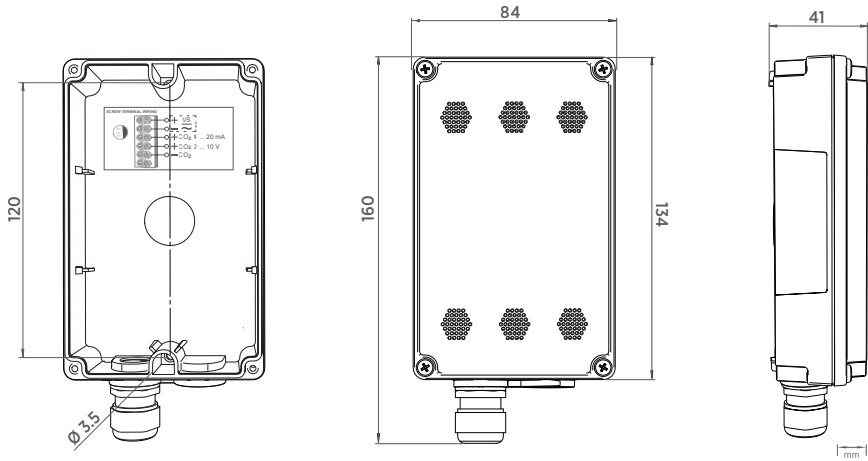

Figure 33 Dimensions for GMW87 and GMW88

# Appendix A. Modbus reference

## A.1 Function codes

Table 13 Modbus function codes

Function code (decimal)	Function code (hexadecimal)	Name
03	03 <sub>hex</sub>	Read Holding Registers
43/14	2B <sub>hex</sub> / 0E <sub>hex</sub>	Read Device Identification

## A.2 Data encoding

In the data registers, the numeric values are available in one or two formats with separate register addresses: 32-bit IEEE floating point format and/or 16-bit signed integer format.

### A.2.1 32-bit floating point format

Registers using **32-bit float** data format are encoded using the **binary32** encoding defined in IEEE 754. The format is also known as "single-precision floating point format".

The least significant 16 bits of a floating point number are placed at the Modbus register listed in the table, while the most significant 16 bits are placed in the register with number/ address + 1, as specified in Open Modbus TCP Specification, Release 1.0. This is also known as "little-endian" or "Modicon" word order.

Despite the specification, some Modbus masters may expect a "big-endian" word order (most significant word first). In such case, you must select "word-swapped" floating point format in your Modbus master for the Modbus registers of the device.



A complete 32-bit floating point or integer value should be read in a single Modbus transaction.



Reading the measurement data registers with incorrect floating point format setting may occasionally result in correct-looking values. It is highly recommended to verify that you have configured the floating point format correctly on your Modbus host system by reading a floating point value from a test value register.

## A.2.2 16-bit integer format

Table 14 Interpretation of 16-bit signed integer values

Value	Description
0000 <sub>hex</sub> ... 7FFE <sub>hex</sub>	Value in range 0 ... 32766
8002 <sub>hex</sub> ... FFFF <sub>hex</sub>	Value in range -32766 ... -1 (2's complement)
8000 <sub>hex</sub>	Value is not available

The 16-bit integer value for measured temperature in Table 15 (page 50) is scaled to include the necessary decimals.

## A.3 Modbus registers



**CAUTION!** Registers are numbered in decimal, starting from 1. Register addresses in actual Modbus messages (Modbus Protocol Data Unit (PDU)) are in hexadecimal and start from zero. Subtract 1 from the register number presented in this manual to get the address used in the Modbus message (for example, register number 1 corresponds to address 0<sub>hex</sub> in the actual Modbus message).

Accessing unavailable (temporarily missing) measurement data does not generate a Modbus exception. “Unavailable” value (a quiet NaN for floating point data or 8000<sub>hex</sub> for integer data) is returned instead. An exception is generated only for any access outside the applicable register ranges.

### A.3.1 Measurement data registers

Table 15 Modbus measurement data registers (read-only)

Register number	Address	Register description	Data format	Unit
1	0000 <sub>hex</sub>	Measured CO <sub>2</sub> value	32-bit float	ppm
5	0004 <sub>hex</sub>	Measured temperature <sup>1)</sup>	32-bit float	°C
257	0100 <sub>hex</sub>	Measured CO <sub>2</sub> value	16-bit integer	ppm
259	0102 <sub>hex</sub>	Measured temperature (T * 10) <sup>1)</sup>	16-bit integer	°C

1) Device internal temperature measurement. Measurement accuracy not specified.

## A.3.2 Status registers

Table 16 Modbus status registers (read-only)

Register number	Address	Register description	Data format	Notes
513	0200 <sub>hex</sub>	Device status	16-bit integer	<b>0000</b> <sub>hex</sub> : Status OK; if other values are returned, see <a href="#">Table 6 (page 41)</a> in <a href="#">Solving typical problems (page 39)</a> .
514	0201 <sub>hex</sub>	Error code	32-bit integer	Used by Vaisala Technical Support when solving device problems
519	0206 <sub>hex</sub>	Temperature measurement status <sup>1)</sup>	16-bit integer	<b>0000</b> <sub>hex</sub> : Status OK <b>0004</b> <sub>hex</sub> : Under range <b>0008</b> <sub>hex</sub> : Over range <b>0080</b> <sub>hex</sub> : Sensor failure <b>0100</b> <sub>hex</sub> : Measurement not ready <sup>2)</sup>
520	0207 <sub>hex</sub>	CO <sub>2</sub> measurement status		

1) Device internal temperature measurement. Measurement accuracy not specified.

2) Applicable to CO<sub>2</sub> measurement only.

## A.3.3 Test value registers

Read the known test values from the test registers to verify the functionality of your Modbus implementation.

Table 17 Modbus test registers (read-only)

Register number	Register address	Register description	Data format	Test value
7937	1F00 <sub>hex</sub>	Signed integer test	16-bit integer	-12345
7938	1F01 <sub>hex</sub>	Floating point test	32-bit float	-123.45
7940	1F03 <sub>hex</sub>	Text string test	text	Text string: "-123.45"

## A.4 Device identification objects

Table 18 Device identification objects

Object ID	Object ID (hexadecimal)	Object name	Example contents
0	00 <sub>hex</sub>	VendorName	"Vaisala"
1	01 <sub>hex</sub>	ProductCode	"GMW80"
2	02 <sub>hex</sub>	MajorMinorVersion	Software version (for example, "1.4.0")
3	03 <sub>hex</sub>	VendorUrl	"https://www.vaisala.com/"
4	04 <sub>hex</sub>	ProductName	"Vaisala CARBOCAP(R) Carbon Dioxide Transmitter GMW80"
128	80 <sub>hex</sub>	SerialNumber <sup>1)</sup>	Transmitter serial number, e.g. "J1140501"

1) *Vaisala-specific device information object.*

## A.5 Modbus communication example

### Reading CO<sub>2</sub> concentration value



The device address used in the following example is 240 (F0<sub>hex</sub>). The values returned by the device differ depending on the ambient conditions. Your device might not return exactly the same values.

Request		Response	
Bytes on the line	Description	Bytes on the line	Description
(silence for 3.5 bytes)	Start of Modbus RTU frame	(silence for 3.5 bytes)	Start of Modbus RTU frame
F0 <sub>hex</sub>	Transmitter address	F0 <sub>hex</sub>	Transmitter address
03 <sub>hex</sub>	Function (Read Holding Registers)	03 <sub>hex</sub>	Function (Read Holding Registers)
00 <sub>hex</sub>	Register address	04 <sub>hex</sub>	Number of data bytes
00 <sub>hex</sub>		E6 <sub>hex</sub>	Value of first register (least significant word)
00 <sub>hex</sub>	Number of 16-bit registers to read (2)	3A <sub>hex</sub>	
02 <sub>hex</sub>		44 <sub>hex</sub>	
D1 <sub>hex</sub>	Modbus RTU checksum	17 <sub>hex</sub>	Modbus RTU checksum
2A <sub>hex</sub>		7E <sub>hex</sub>	
(silence for 3.5 bytes)	End of Modbus RTU frame	B7 <sub>hex</sub>	
		(silence for 3.5 bytes)	End of Modbus RTU frame

Communication description	
Register number	1 (1-based Modbus register number) = address 0000 <sub>hex</sub> (0-based address used in actual communication).
Data format	Two 16-bit Modbus registers interpreted as IEEE 754 binary32 floating point value, least significant word first.
Returned value	4417E63A <sub>hex</sub> , which is binary32 representation of 607.6 (ppm CO <sub>2</sub> ).





## Maintenance and calibration services



Vaisala offers comprehensive customer care throughout the life cycle of our measurement instruments and systems. Our factory services are provided worldwide with fast deliveries. For more information, see [www.vaisala.com/calibration](http://www.vaisala.com/calibration).

- Vaisala Online Store at [store.vaisala.com](http://store.vaisala.com) is available for most countries. You can browse the offering by product model and order the right accessories, spare parts, or maintenance and calibration services.
- To contact your local maintenance and calibration expert, see [www.vaisala.com/contactus](http://www.vaisala.com/contactus).

## Warranty

For standard warranty terms and conditions, see [www.vaisala.com/warranty](http://www.vaisala.com/warranty).

Please observe that any such warranty may not be valid in case of damage due to normal wear and tear, exceptional operating conditions, negligent handling or installation, or unauthorized modifications. Please see the applicable supply contract or Conditions of Sale for details of the warranty for each product.

## Technical support



Contact Vaisala technical support at [helpdesk@vaisala.com](mailto:helpdesk@vaisala.com). Provide at least the following supporting information as applicable:

- Product name, model, and serial number
- Software/Firmware version
- Name and location of the installation site
- Name and contact information of a technical person who can provide further information on the problem

For more information, see [www.vaisala.com/support](http://www.vaisala.com/support).

## Recycling



Recycle all applicable material.



Follow the statutory regulations for disposing of the product and packaging.





# VAISALA



kenelec  
scientific  
measuring up

Distributed by:

Kenelec Scientific Pty Ltd  
1300 73 22 33  
sales@kenelec.com.au  
www.kenelec.com.au

[www.vaisala.com](http://www.vaisala.com)

