



# HMP5 Relative Humidity and Temperature Probe

## For High Temperatures



### Features

- RH accuracy up to  $\pm 0.8\%$  RH
- Temperature accuracy up to  $\pm 0.1\text{ }^{\circ}\text{C}$  ( $\pm 0.18\text{ }^{\circ}\text{F}$ )
- Temperature measurement range  $-70 \dots +180\text{ }^{\circ}\text{C}$  ( $-94 \dots +356\text{ }^{\circ}\text{F}$ )
- Operating temperature range for probe body  $-40 \dots +80\text{ }^{\circ}\text{C}$  ( $-40 \dots +176\text{ }^{\circ}\text{F}$ )
- Sensor purge provides superior chemical resistance
- Modbus RTU over RS-485
- 250-mm (9.84 in) probe allows easy process installation through insulation
- Compatible with Indigo transmitters and Insight PC software
- Traceable calibration certificate: 6 points for humidity, 1 point for temperature

Vaisala HUMICAP® Humidity and Temperature Probe HMP5 is designed for high-temperature applications such as baking ovens, pasta dryers, and industrial drying kilns, where measurement performance and chemical tolerance are essential.

### Proven Vaisala HUMICAP® Performance

Vaisala is the original innovator of the thin-film capacitive humidity measurement technology, which has now become the industry standard in humidity measurement.

HUMICAP® technology results from Vaisala's 40-year experience in industrial humidity measurement, providing the best stability, fast response time, and low hysteresis in a wide range of applications.

### Chemical Purge Minimizes Effects of Contaminants

In environments with high concentrations of chemicals and cleaning agents, the chemical purge option helps to maintain measurement accuracy between calibration intervals.

The chemical purge involves heating the sensor to remove harmful chemicals. The function can be initiated manually or programmed to occur at set intervals.

### Flexible Connectivity

The probe is compatible with Vaisala Indigo series of transmitters, and it can be used as a standalone digital Modbus RTU transmitter over RS-485 serial bus. For easy-to-use access to field calibration, device analytics, and configuration functionality, the probe can be connected to Vaisala Insight software for Windows®: see [www.vaisala.com/insight](http://www.vaisala.com/insight).

### Vaisala Indigo Product Family

Indigo transmitters offer a variety of connectivity options through analog signals or digital outputs, configurable relays, and wireless (WLAN) configuration interface, providing a suitable solution for all industrial humidity measurements. The cable length between the probe and transmitter can be extended to up to 30 meters. For more information, see [www.vaisala.com/indigo](http://www.vaisala.com/indigo).

# Technical Data

## Measurement Performance

### Relative Humidity

Measurement range	0 ... 100 %RH
Accuracy at +23 °C (+73.4 °F) <sup>1)</sup>	±0.8 %RH (0 ... 90 %RH)
Factory calibration uncertainty <sup>2)</sup>	±0.5 %RH (0 ... 40 %RH) ±0.8 %RH (40 ... 95 %RH)
T <sub>63</sub> response time	15 s
Sensor options	HUMICAP® R2 HUMICAP® R2C <sup>3)</sup>

### Temperature

Measurement range	-70 ... +180 °C (-94 ... +356 °F)
Accuracy at +23 °C (+73.4 °F) <sup>1)</sup>	±0.1 °C (±0.18 °F)
Factory calibration uncertainty <sup>2)</sup>	±0.1 °C (±0.18 °F) at +23 °C (+73.4 °F)
Sensor	Pt100 RTD Class F0.1 IEC 60751

- 1) Defined against calibration reference. Including non-linearity, hysteresis, and repeatability.  
 2) Defined as ±2 standard deviation limits. Small variations possible; see calibration certificate.  
 3) Chemical purge feature available with this sensor

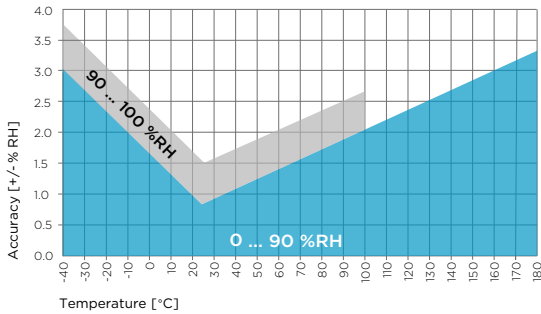

HMP5 Humidity Measurement Accuracy as a Function of Temperature

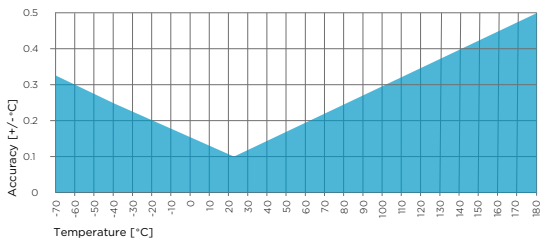

HMP5 Temperature Measurement Accuracy over Full Range

## Accessories

Mounting flange	210696
USB PC connection cable <sup>1)</sup>	242659

1) Vaisala Insight software for Windows available at [www.vaisala.com/insight](http://www.vaisala.com/insight)

## Operating Environment

Operating temperature for probe body	-40 ... +80 °C (-40 ... +176 °F)
Operating temperature for probe head	-70 ... +180 °C (-94 ... +356 °F)
Operating environment	Suitable for outdoor use
IP rating of probe body	IP66
EMC compliance	EN61326-1, Industrial environment

## Inputs and Outputs

Operating voltage	15 ... 30 VDC
Current consumption	10 mA typical, 500 mA max.
Digital output	RS-485, non-isolated
Protocols	Modbus RTU

### Output Parameters

Relative humidity, temperature, dew point temperature, wet-bulb temperature, absolute humidity, mixing ratio, water concentration, water mass fraction, water vapor pressure, enthalpy

## Mechanical Specifications

Connector	M12 5-pin A-coded male
Weight	436 g (15.37 oz)
<b>Materials</b>	
Probe	AISI316L
Probe body	AISI316L
Cable jacket	FEP

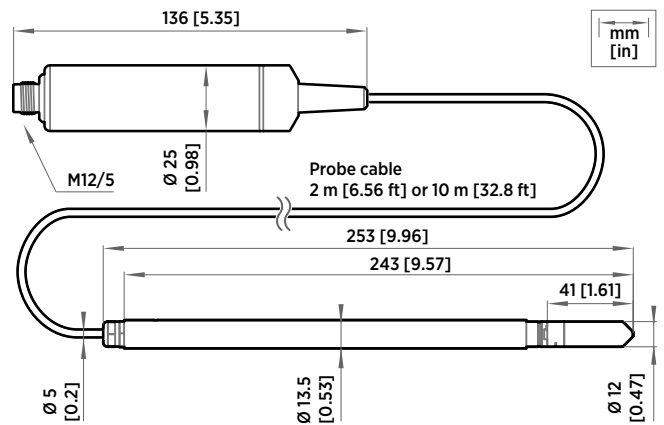

HMP5 Probe Dimensions



[www.vaisala.com](http://www.vaisala.com)

Published by Vaisala | B211684EN-C © Vaisala Oyj 2019

All rights reserved. Any logos and/or product names are trademarks of Vaisala or its individual partners. Any reproduction, transfer, distribution or storage of information contained in this document is strictly prohibited. All specifications – technical included – are subject to change without notice.



Distributed by: Kenelec Scientific Pty Ltd | 1300 73 22 33 | [sales@kenelec.com.au](mailto:sales@kenelec.com.au) | [www.kenelec.com.au](http://www.kenelec.com.au)