



RPS-24VDC Remote Power Supply Operation Manual

Rev B | 2016.11

www.critical-environment.com



Conforms to: EMC Directive 2004/108/EC
EN 50270:2006, Type 1, EN61010

Conforms to: FCC. This device complies with Part 15 of the FCC Rules. Operation is subject to the following two conditions: (1) This device may not cause harmful interference, and (2) this device must accept any interference received, including interference that may cause undesired operation.

Standard Enclosure Dimensions

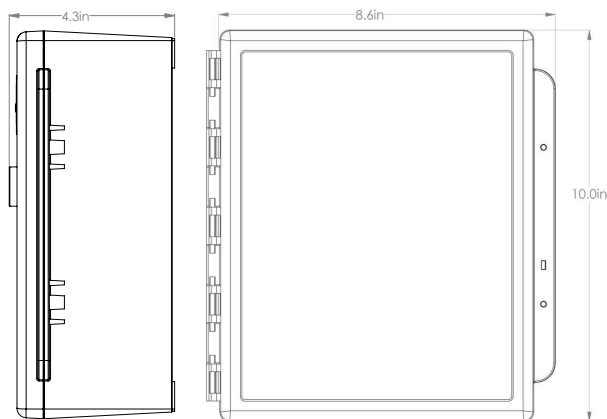

~5~

INTRODUCTION

The RPS-24VDC is a remote power supply for large fixed system applications and/or long wire runs. It converts 90 - 240 VAC power to 24 VDC power, providing a renewed amount of power to compensate for voltage drops. Projects requiring a large number of gas detectors or consist of very long wire runs require a remote power supply to boost the voltage to the last transmitter on the network run and to reinforce the voltage provided by the Controller to the first line of transmitters.

The RPS-24VDC comes in a standard water / dust tight, corrosion resistant ABS / polycarbonate enclosure with a hinged, secured door.

Ideal for large applications to create an efficient distribution network of specialized gas detection devices that can communicate over a large distance.

Key Features

- » Supplies power to a large gas detection system
- » Boosts power on long wire runs that present a voltage loss condition
- » Standard, dust / water tight, corrosion resistant enclosure (drip proof)

If after reading through this manual, you have any questions, please do not hesitate to contact our service department for technical support.

~2~

Critical Environment Technologies Canada Inc.

Unit 145, 7391 Vantage Way, Delta, BC V4G 1M3

Toll Free: +1.877.940.8741

Telephone: 604.940.8741

service@cetci.com

Fax: 604.940.8745

www.critical-environment.com

This product must be installed and inspected by a qualified electrician or factory trained technician. This instrument has not been designed to be intrinsically safe. For your safety, **do not** use it in classified hazardous areas (explosion-rated environments).

INSTRUMENT SPECIFICATIONS

Technical Specifications

MECHANICAL

Enclosure	ABS / Polycarbonate. Copper coated interior to reduce RF interference.
Weight	1.4 kg (3.0 lbs)
Size	254 mm x 218 mm x 109 mm (10.0" x 8.6" x 4.3")

~3~

ELECTRICAL

Power Requirements	90 - 240 VAC, 50 - 60 Hz, Line Voltage
Output	24 VDC, 75 W
Wiring	4-wire shielded in conduit network wiring between the devices
Fuses	Thermal, resetting

ENVIRONMENTAL

Operating Temperature	-20°C to 40°C (-4°F to 104°F)
Humidity	12 to 90% non-condensing

CERTIFICATION

Model: RPS-24VDC

S/N: RPSVDC1603B00001

Rating: 90-240 VAC, 50-60 Hz, 75 W, Class 2



CERTIFIED FOR ELECTRIC SHOCK & ELECTRICAL FIRE HAZARD ONLY. LA CERTIFICATION ACNOR COUVRE UNIQUEMENT LES RISQUES DE CHOC ELECTRIQUE ET D'INCENDIE D'ORIGINE ELECTRIQUE.

Conforms to: CSA-C22.2 No. 205-12
UL508 (Edition 17):2007

~4~

Exterior Enclosure - Front



NUMBER	FEATURE	FUNCTION
1	Door Hinge	Secures door
2	Door Screw	Secures door
3	Padlock Opening	For security padlock

~6~

Interior System Layout

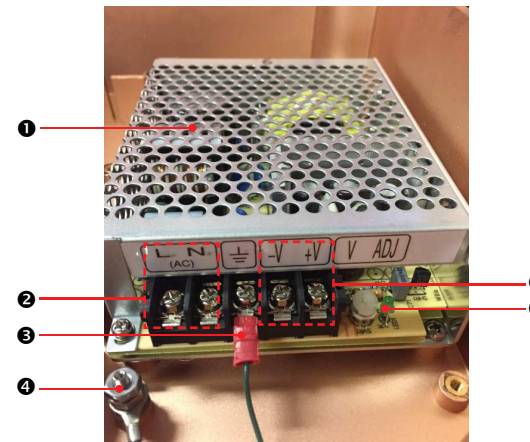

NUMBER	FEATURE	FUNCTION
1	Metal Cage	Protection from high voltage area
2	AC Input	90 - 240 VAC, 50 - 60 Hz Line voltage
3	Ground Terminal	Earth/safety ground connection
4	Earth Ground	Earth/safety ground connection

~7~

Interior Enclosure - Base

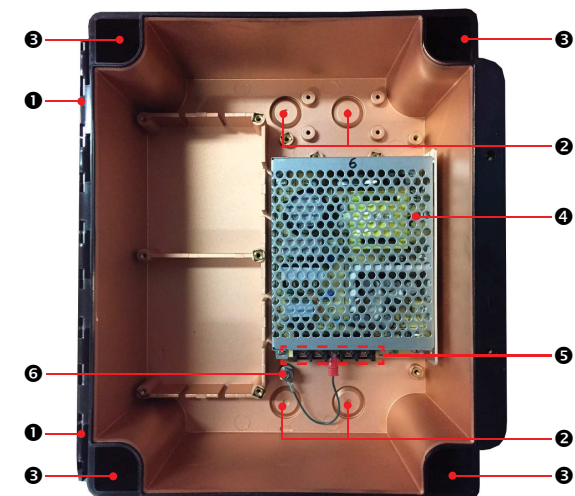

~8~

5	DC Output	24 VDC, 75 W
6	Adjustment	24 VDC adjustment

NUMBER	FEATURE
①	Door Hinge
②	1/2" Conduit Entry Knockout
③	Mounting Holes
④	Metal protective cage
⑤	Input and output wiring connections
⑥	Earth Ground

INSTALLATION

The RPS-24VDC should be installed on a flat vertical surface using the four 4.4 mm (0.175") diameter mounting holes provided to maintain water tight status. There are also four areas that can be drilled out for mounting to a double gang electrical box.

There are six conduit entry points for the standard mounting setup (against a flat surface). Three entry points are located along the top of the enclosure and three are located along the bottom. These points must be drilled out as needed. **Do not use a conduit connector that has more than 12.7 mm (1/2 in) of thread length.**

~9~

NOTE: When mounting the enclosure, allow enough room to allow the end user to open the door fully to access the wiring terminal.

The RPS-24VDC is intended for indoor use and should be protected from extreme weather conditions. The RPS-24VDC requires no assembly and virtually no maintenance other than ensuring that excess water or dust is not somehow entering the enclosure and physically damaging the circuit board or internal components. There are no serviceable or replaceable elements or components in this device.

WIRING CONNECTIONS

All wiring should be run within properly grounded (earth or safety) conduit. Signal output and supply should be in shielded cable. The cable shield should be connected to earth ground.

Wiring Power Connections

Warning High Voltage. Disconnect all power before servicing. There may be multiple power sources. Power supply must have a building installed circuit breaker /switch that is suitably located and easy to access when servicing is required

~10~

Wiring Between Two Digital Transmitters

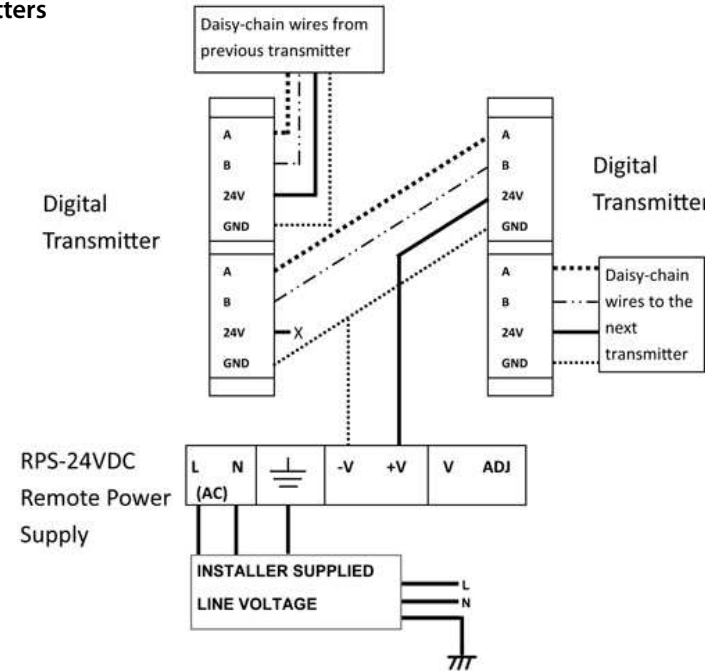

Double check wiring connections prior to powering the RPS-24VDC. Damage from incorrect wiring connections or from incorrect voltage supply applied is not covered under warranty.

External power to the RPS-24VDC must be supplied by a 90 - 240 VAC power supply or a Class 2 (or better) transformer and connected to the AC Input wiring terminal. The wiring should be 4-conductor shielded 16 awg stranded and run within properly grounded (earth or safety) conduit. Building code requires low voltage wiring not to be within the same conduit as line voltage wiring.

NOTE: Observe polarity when connecting DC load to the output of the power supply.

NOTE: WARRANTY VOID IF SOLID-CORE WIRE IS USED AT THE WIRING TERMINAL STRIP. When using solid core wiring for distribution (in the conduit), use stranded wire pigtailed 18 AWG within the enclosure to connect to the circuit board. The rigidity of solid-core wire can pull a soldered terminal strip completely off a circuit board and this will not be covered under warranty.



© 2016 Critical Environment Technologies Canada Inc.
Data subject to change without notice.

~11~

Wiring To LNK-Xt Network Extender

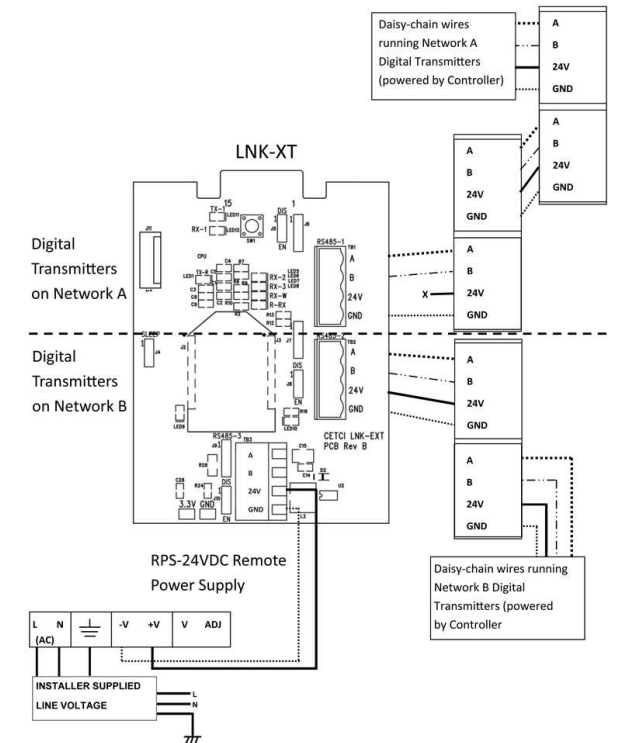

Distributed by:
Kenelec Scientific Pty Ltd
1300 73 22 33
sales@kenelec.com.au
www.kenelec.com.au