

MODEL TF-SERIES FLOW STATION

INSTALLATION INSTRUCTIONS

WARNING

The Model TF-Series Flow Stations must be wired to 24 VAC only. Wiring the unit to 110 VAC will cause serious damage to the unit and void the warranty.

Figure 1. TF-Series Thermal Flow Station

TF-Series Flow Station Placement

The following paragraphs detail the procedure for determining optimum placement of the TF-Series Flow Station in typical installation applications.



CAUTION

Installation of the TF-Series Flow Station with straight duct lengths equal to or greater than indicated in the Minimum Placement Guidelines below is critical for proper performance of the airflow measurement station.

Minimum Placement Guidelines

Placement of the TF-Series Flow Station is critical for proper operation and accuracy of the airflow measurement station. Figure 2 shows minimum placement requirements for the TF-Series Flow Station in typical applications. Probe placement is expressed in multiples of 'Simple Equivalent Duct Diameter - "D," which is determined as follows:

$$D = (\text{duct width} + \text{duct height}) / 2$$

1. Using the illustration in Figure 2 that most closely matches the installation, multiply the calculated "D" value from above by the value indicated in the application illustration. This is the calculated location for the TF-Series Flow Station.
2. Mark the duct location and install the TF-Series Flow Station at the calculated location.

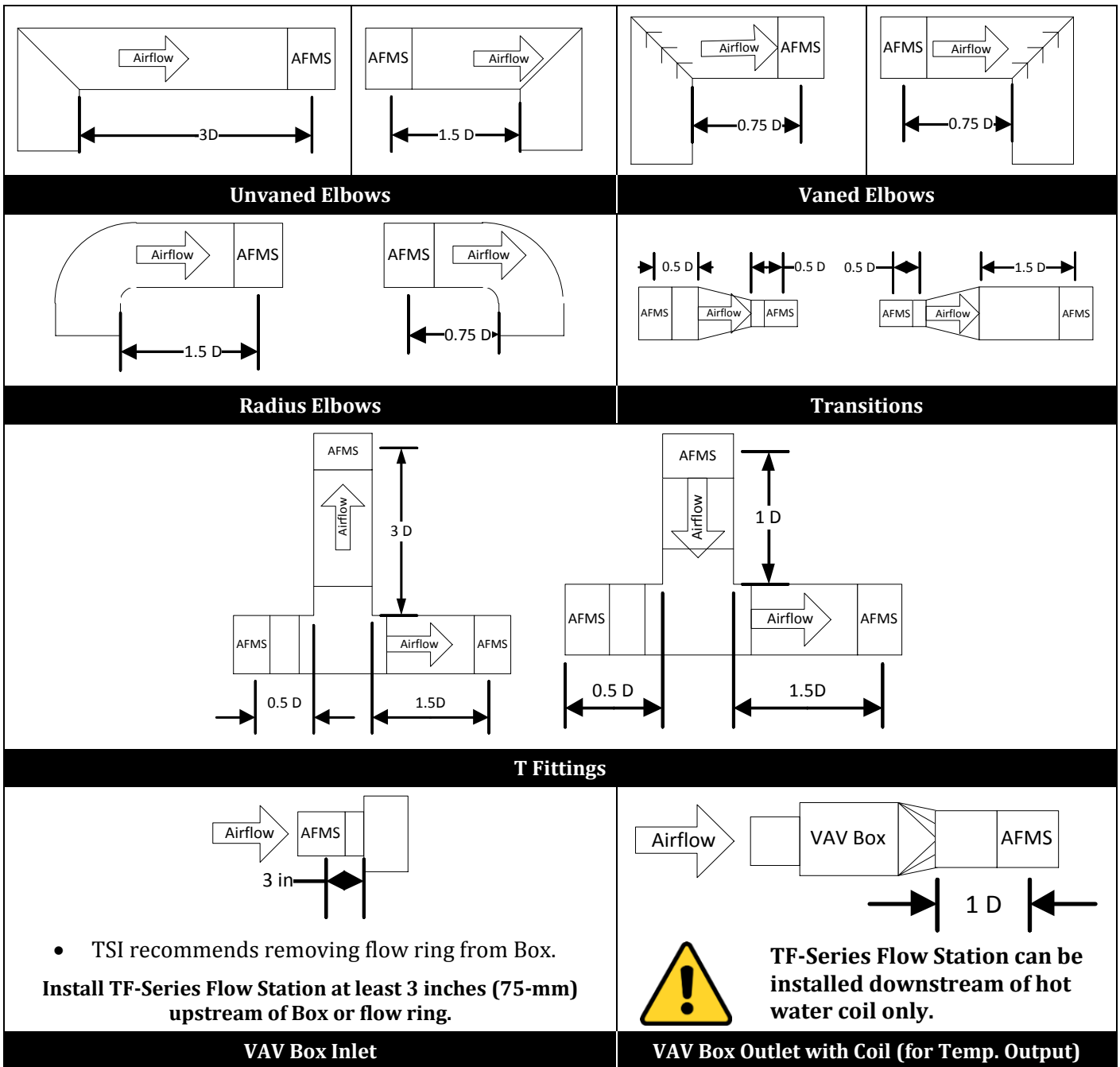

Figure 2. TF-Series Flow Station Minimum Placement Requirements Guide

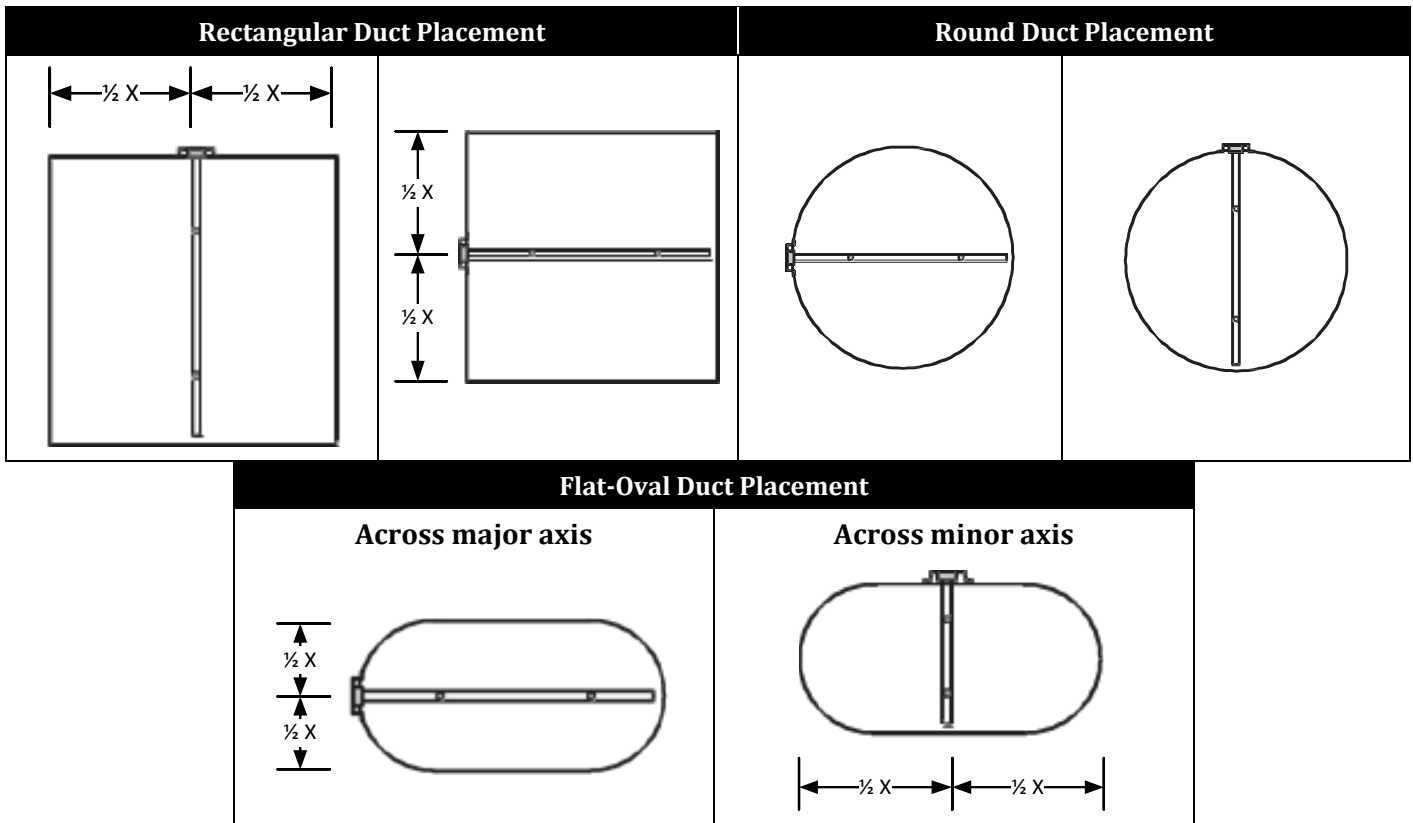

Figure 3. TF-Series Installation Flow Station Applications and Orientation

TF-Series Flow Station Installation

The TF-Series Flow Station is designed for use indoors in ducts up to 16 inches and in VAV terminal box applications TF-Series airflow measurement station sensor probes are designed for insertion mounting through one side of the duct or VAV box. Mount the instrument in an accessible location to permit set up. Locate the instrument so that the attached instrument cable will reach the TSI controller or customer-provided junction box.



CAUTION

The installed location of the TF-Series Flow Station is critical for proper performance. Refer to the previous [Minimum Placement Guidelines](#) section of this document to determine the recommended location for the TF-Series Flow Station.



CAUTION

Ensure that adequate clearance exists to permit insertion of the probe, and to allow clearance for the instrument enclosure.



CAUTION

External duct insulation that interferes with mounting should be temporarily removed prior to installation. Mounting requires a 0.875 inches (22.2 mm) hole on the insertion side of the duct.

1. Determine where the TF-Series airflow measuring station is to be located as indicated on the engineer's plans.
2. Carefully open the TF-Series Flow Station package and inspect for damage. If damage is noted, immediately file a claim with carrier.

3. Locate and mark the point on the duct or VAV box where the probe will be inserted using the previous [Minimum Placement Guidelines](#) section of this document. Refer to Figure 3 and Figure 4 for TF-Series Flow Station dimensions and probe orientation.
4. Using a 0.875 inch (22.2 mm) hole saw, drill the insertion side hole marked in the previous step.
5. Place the probe through the mounting hole, making sure that the gasket is seated firmly against the integral mounting bracket. Ensure that the edge of the TF-Series Flow Station mounting bracket is parallel to the edge of the duct or VAV terminal box, and that the airflow arrow printed on it is oriented in the direction of actual airflow. Ensure that the gasket is firmly seated against the bracket, and then fasten the mounting bracket at the four mounting holes using appropriate sheet metal screws.
6. Route the TF-Series Flow Station instrument cable to the TSI monitor or controller. Refer to the following sections of this document for instrument set up and operation.

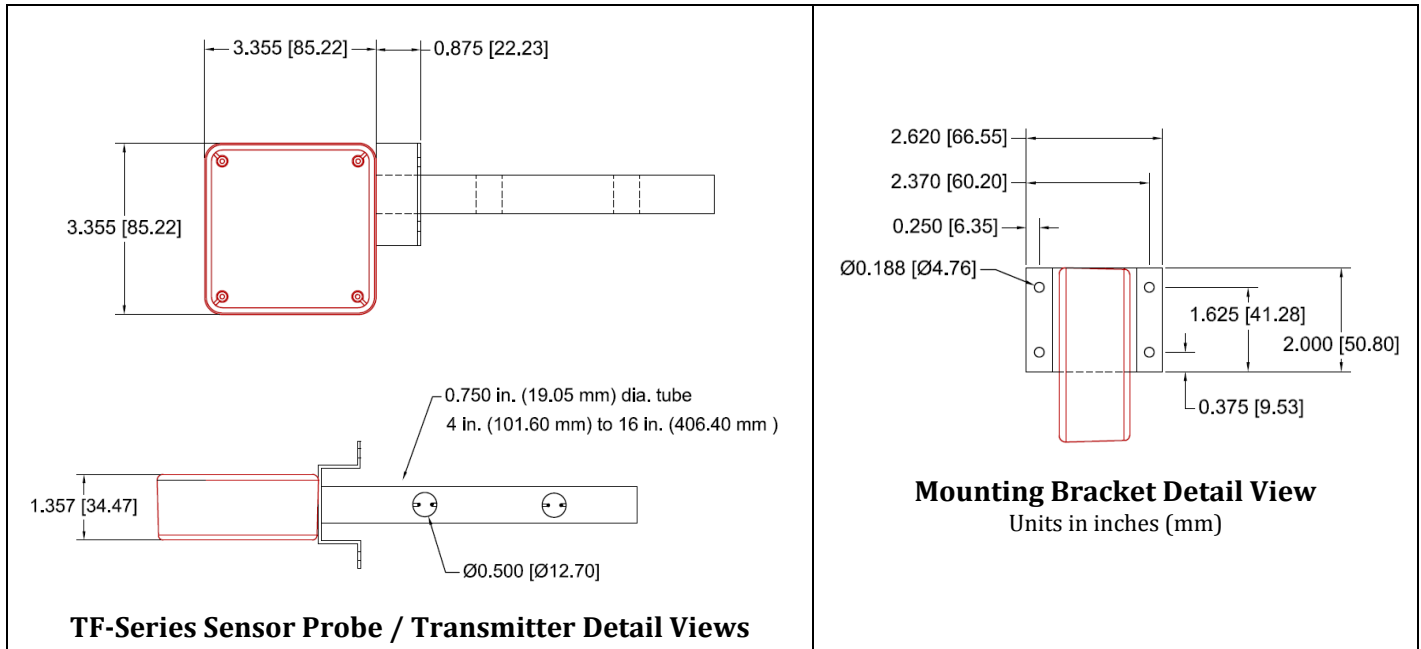

Figure 4. TF-Series Flow Station Installation Dimensions

TF-Series Flow Station—Preparation for Use

Preparation for use consists of connecting 24 VAC power and analog signal output wires from the TF-Series Flow Station to the TSI monitor or controller, and if required, setting the TF-Series Flow Station analog output switch options (measurement mode, output signal type and full scale range options).

TF-Series Flow Station Interconnections

The TF-Series Flow Station is equipped with a plenum rated 18 AWG interconnecting cable for power and analog output(s). Connect 24 VAC power and analog output(s) to TSI monitor or controller as outlined in the following paragraphs. Refer to Figure 5.

TF-Series Analog Output Connections



CAUTION

24 VAC power must be deactivated before making connections to the instrument.



CAUTION

The 24 VAC input ground (GND) connection is shared with the analog output signal ground. If an isolated output is desired, a dedicated isolation transformer is required to power the TF-Series Flow Station.

The TF-Series provides an analog output to indicate airflow or equivalent velocity pressure, with an optional analog output to indicate air temperature. The analog outputs are not isolated from the power input. Connect the analog output at the white wire and the signal common at the black wire to the TSI monitor or controller using twisted pair cable as shown in Figure 5.

TF-Series Flow Station 24 VAC Power Connections



CAUTION

24 VAC power must be deactivated before making connections to the instrument.



CAUTION

The 24 VAC input ground (GND) connection is shared with the analog output signal ground. If an isolated output is desired, a dedicated isolation transformer is required to power the TF-Series Flow Station.

The TF-Series Flow Station requires a power source capable of providing 22.8 to 26.4 VAC at 5 VA. Connect 24 VAC power between the red wire and black wires as shown in Figure 6.

Color	Function
Red	24 VAC power
Black	Common TF-Series Flow Station Power/Signal Ground (for 24 VAC and for analog output)
White	Velocity Analog Output Signal
Green	Temperature Analog Output Signal.
NOTE: Only available on model TF-xx-AL-T Flow Stations	



CAUTION

The TF-Series Flow Stations are equipped with a common 24 VAC ground and analog output signal common(s). The analog output(s) must be wired with dedicated common wire(s). Sharing the common wire with the 24 VAC return may cause voltage drop leading to inaccurate readings.

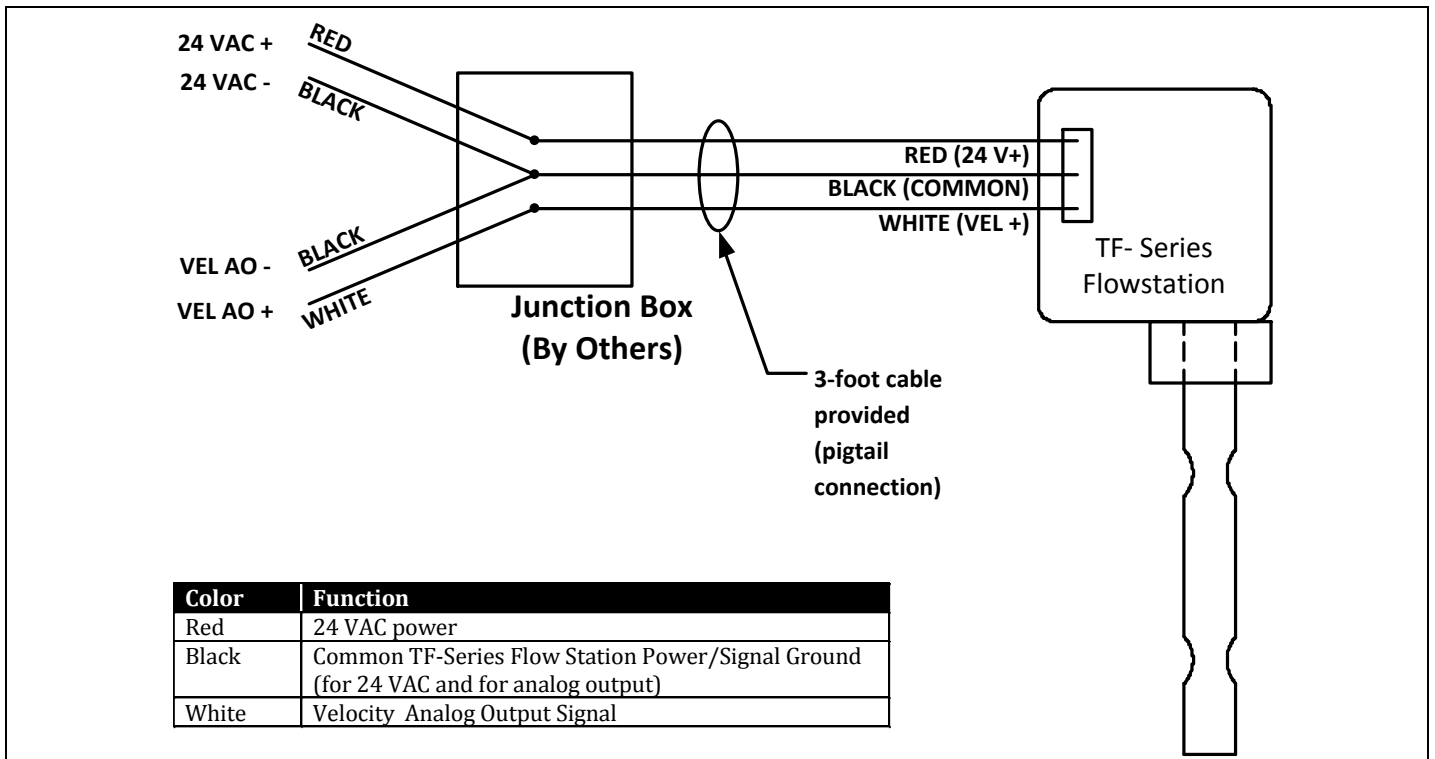

Figure 5. TF-Series Flow Station Wiring

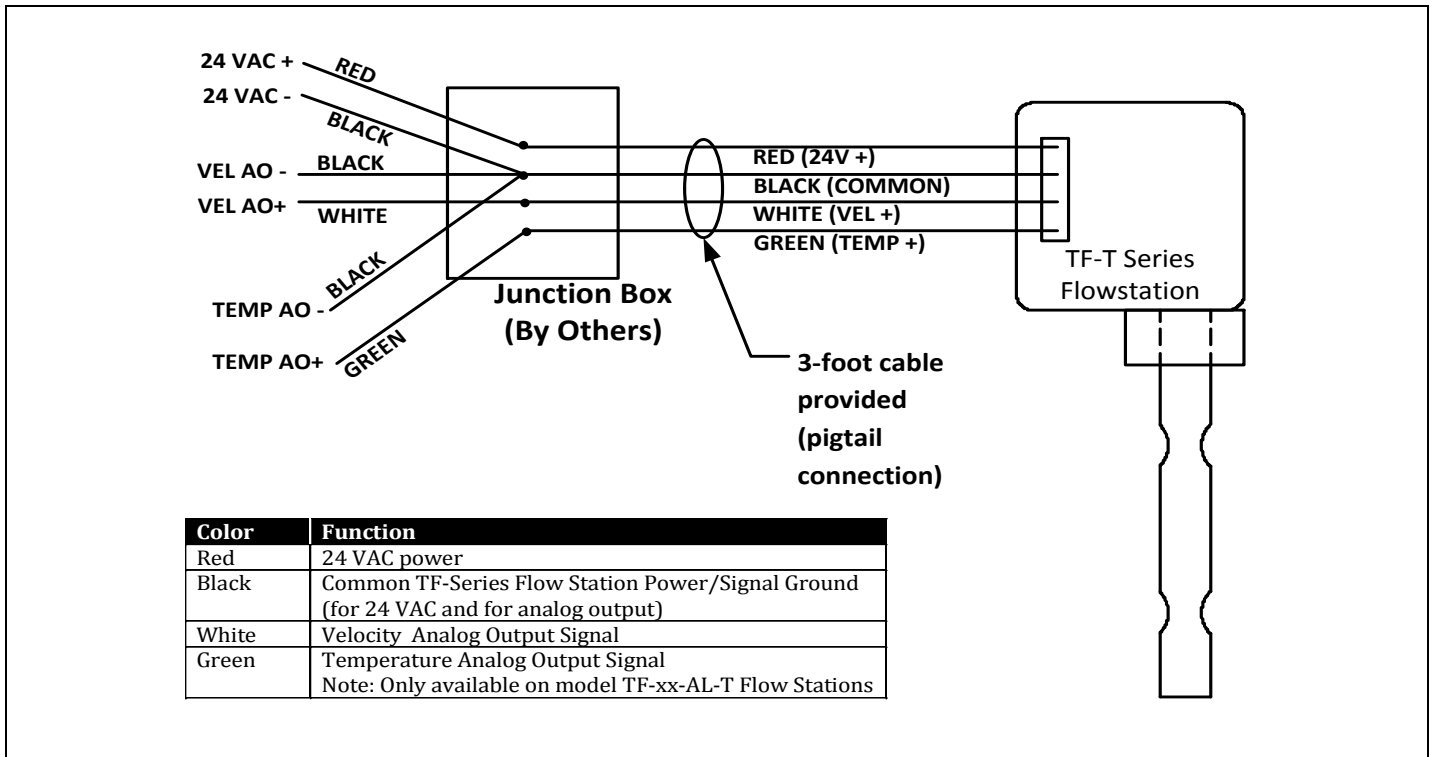

Figure 6. TF-Series Flow Station with Temperature Output Wiring

NOTES:

1. The 24 VAC common and analog output signal commons are non-isolated. Do **not** share power with other non-isolated devices.
2. On multiple TF-Series Flow Station installations ensure that all TF-Series Flow Stations are wired to the same terminals on the 24 VAC power source.
3. Connect cable drains to earth ground at one end of each cable only.

TF-Series Flow Station Analog Output Option Switch Settings

To access the field selectable analog output option switches, remove the four retaining screws at each corner of the TF-Series Flow Station enclosure cover. The option selector switches are part of a four-switch DIP package labeled CONFIG. Figure 7 shows the TF-Series circuit board and individual switches for setting TF-Series Flow Station measurement mode, output voltage and output full-scale values. Factory default switch settings are all OFF, resulting in airflow measurement mode, 0 to 10 VDC analog output and 0 to 3,000 FPM full scale range. If desired, these settings can be changed using the CONFIG switch as shown in Figure 6 and as described in the following paragraphs:

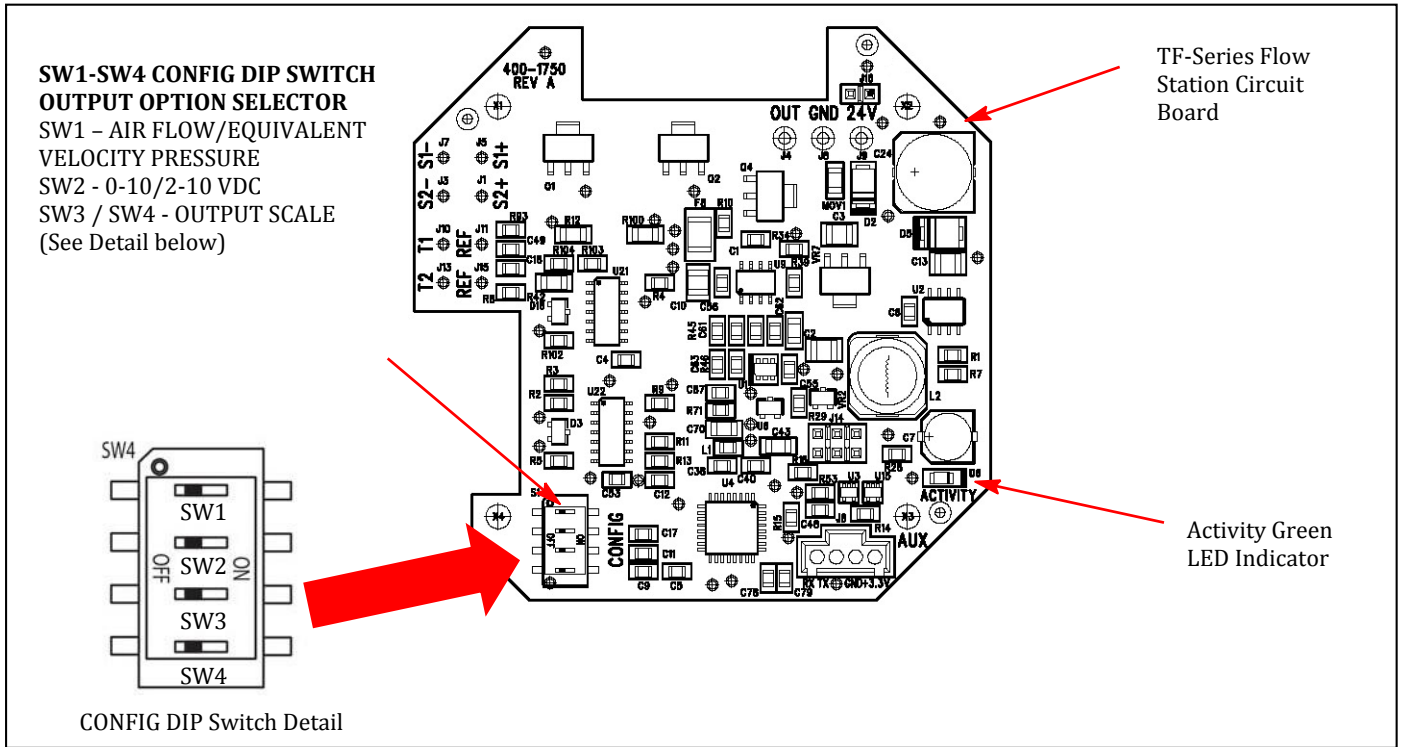

Figure 7. TF-Series Flow Station Circuit Board Detail

Switch 2 Position	Output
OFF (default)	0-10 VDC
ON	2-10 VDC

Switch 1 Position	Switch 3 Position	Switch 4 Position	Full Scale Range
OFF (default)	OFF (default)	OFF (default)	3,000 fpm (15.24 m/s)
OFF	ON	OFF	2,000 fpm (10.16 m/s)
OFF	OFF	ON	1,000 fpm (5.08 m/s)
OFF	ON	ON	500 fpm (2.54 m/s)
ON	OFF	OFF	0.5 in H ₂ O (124.5 Pa)
ON	ON	OFF	0.25 in H ₂ O (62.27 Pa)
ON	OFF	ON	0.15 in H ₂ O (37.36 Pa)
ON	ON	ON	0.05 in H ₂ O (12.45 Pa)

TF-Series Flow Station Initial Start Up / Normal Operation

The following procedure is intended for initial start-up of the TF-Series Flow Station. Following the initial set up, no further user activity is required during normal operation.

1. Remove the cover to the electronics enclosure by removing the four screws on the cover.
2. Make sure that the 24 VAC circuit breaker used to power the TF-Series Flow Station is turned OFF until all wiring is complete!
3. Confirm 24 VAC connection from the power source to the TF-Series Flow Station 24 VAC wire (red wire) as outlined in the TF-Series Flow Station 24 VAC Power Connections section of this document.
4. Confirm common ground 24 VAC and signal ground connection from the power source to the TF-Series Flow Station at the black wire.
5. Confirm TF-Series Flow Station analog signal output connection at the white wire, to the analog input of the BAS as outlined in [TF-Series Analog Output Connections](#) section of this document. Note that the ground of the BAS must be at the same voltage reference as the ground of the TF-Series Flow Station and the power source.
6. Set the desired analog output options using CONFIG switches SW1 to SW4 as outlined in the [TF-Series Flow Station Analog Output Option Switch Settings](#) section of this document.
7. Activate the 24 VAC power source to power on the TF-Series Flow Station.
8. Check to confirm that the TSI controller or BAS is receiving the analog output signal indicating instrument airflow or equivalent velocity pressure.
9. Following a brief instrument initialization, the green Activity LED will continuously flash ON for 1 second, then OFF for 1 second. This indicates normal operation. In the event of a sensor fault, the LED will continuously flash ON for 2 seconds, and OFF for 2 seconds.

Converting the Output Signal from Linear to Volumetric Flow—FPM to CFM

The TF-Series Flow Station analog output airflow (FPM) can easily be converted to an equivalent volumetric flow (CFM) by multiplying the indicated flow velocity by the free area at the sensor installation location (in square feet). For example, assuming an installation in a 12-inch round duct, using the 0 to 10 VDC scale and the 3,000 FPM full scale output range options, an output of 5 VDC from the TF-Series Flow Station indicates a flow velocity of 1,500 FPM. (5 VDC is one-half of the 0 to 10 VDC output, corresponding to one-half of the 0 to 3,000 FPM scale, which equals 1,500 FPM). The TF-Series Flow Station installed duct location area in this example is calculated at 0.785 ft² (using $\pi \times$ the duct radius², or 3.14 x 0.5 ft²). Multiplying the indicated instrument output of 1,500 FPM by 0.785 ft² yields an equivalent volumetric flow of 1,177.5 CFM.

Maintenance

In most HVAC environments, periodic maintenance and calibration is not required or recommended*.

*Depending on the application, it may be necessary to periodically inspect and clean sensors using compressed air or a small brush. Factory performance returns immediately after cleaning. Recalibration is NOT required. Periodic inspection of the sensors is advised, and accessibility must be considered in these applications.



Distributed by:
Kenelec Scientific Pty Ltd
1300 73 22 33
sales@kenelec.com.au
www.kenelec.com.au

TSI Incorporated – Visit our website www.tsi.com for more information.

USA Tel: +1 800 874 2811
UK Tel: +44 149 4 459200
France Tel: +33 1 41 19 21 99

Germany Tel: +49 241 523030
India Tel: +91 80 67877200

China Tel: +86 10 8219 7688
Singapore Tel: +65 6595 6388

P/N 6008233 Rev. C ©2018 TSI Incorporated Printed in U.S.A.

