

# User Guide

Vaisala VaiNet Wireless Data Logger

**RFL100**

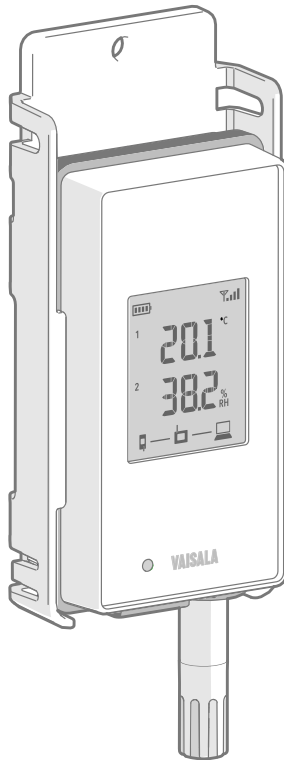

**VAISALA**

## PUBLISHED BY

Vaisala Oyj  
Vanha Nurmijärventie 21, FI-01670 Vantaa, Finland  
P.O. Box 26, FI-00421 Helsinki, Finland  
+358 9 8949 1

Visit our Internet pages at [www.vaisala.com](http://www.vaisala.com).

© Vaisala Oyj 2019

No part of this document may be reproduced, published or publicly displayed in any form or by any means, electronic or mechanical (including photocopying), nor may its contents be modified, translated, adapted, sold or disclosed to a third party without prior written permission of the copyright holder. Translated documents and translated portions of multilingual documents are based on the original English versions. In ambiguous cases, the English versions are applicable, not the translations.

The contents of this document are subject to change without prior notice.

Local rules and regulations may vary and they shall take precedence over the information contained in this document. Vaisala makes no representations on this document's compliance with the local rules and regulations applicable at any given time, and hereby disclaims any and all responsibilities related thereto.

This document does not create any legally binding obligations for Vaisala towards customers or end

users. All legally binding obligations and agreements are included exclusively in the applicable supply contract or the General Conditions of Sale and General Conditions of Service of Vaisala.

This product contains software developed by Vaisala or third parties. Use of the software is governed by license terms and conditions included in the applicable supply contract or, in the absence of separate license terms and conditions, by the General License Conditions of Vaisala Group.

This product may contain open source software (OSS) components. In the event this product contains OSS components, then such OSS is governed by the terms and conditions of the applicable OSS licenses, and you are bound by the terms and conditions of such licenses in connection with your use and distribution of the OSS in this product. Applicable OSS licenses are included in the product itself or provided to you on any other applicable media, depending on each individual product and the product items delivered to you.

## Table of Contents

<b>1.</b>	<b>About This Document</b> .....	5
1.1	Version Information.....	5
1.2	Related Manuals.....	5
1.3	Documentation Conventions.....	6
1.4	Trademarks.....	6
<b>2.</b>	<b>Product Overview</b> .....	7
2.1	RFL100 Overview.....	7
2.1.1	Probe Interface.....	8
2.2	RFL100 Parts.....	9
2.3	RFL100 Batteries.....	11
2.3.1	Battery Level Indicator.....	11
2.4	Alarm Indicators.....	12
2.4.1	Alarm Examples.....	13
2.5	Service Port.....	14
2.5.1	Files and Folders in USB Filesystem.....	15
2.6	Data Transfer in a VaiNet Network.....	15
2.7	Regulatory Compliance.....	16
2.7.1	FCC Compliance Statement.....	16
2.7.2	ISED Compliance Statement.....	17
2.7.3	EU Declaration of Conformity.....	17
2.7.4	UAE Compliance.....	19
2.8	Safety.....	19
2.9	Symbols in RFL100 Product Markings.....	20
2.10	ESD Protection.....	20
<b>3.</b>	<b>Installation</b> .....	21
3.1	Setting Up RFL100 Data Logger.....	21
3.2	Mounting RFL100.....	22
3.2.1	Mounting HMP110 Probes.....	24
3.2.2	Mounting HMP115 Probes.....	24
3.2.3	Mounting TMP115 Probes.....	25
3.3	Connection Indicators.....	25
3.3.1	Connection Examples.....	27
<b>4.</b>	<b>Operation</b> .....	28
4.1	Remote Management.....	28
4.2	Releasing RFL100 from viewLinc Monitoring System.....	29
4.2.1	Releasing Using Release Button.....	30
4.2.2	Releasing Remotely Using viewLinc.....	30
4.3	Speeding Up Radio Scanning Temporarily.....	31
4.4	Vaisala Insight Software.....	32
4.4.1	Connecting Probe to Insight Software.....	33

- 5. Maintenance.....34**
- 5.1 Cleaning RFL100..... 34
- 5.2 Changing the Probe Filter..... 34
- 5.3 Replacing the Probe..... 35
- 5.4 Calibration and Adjustment..... 38
  - 5.4.1 Calibration and Adjustment Environments..... 38
  - 5.4.2 Field Checking Using a Reference Instrument..... 39
  - 5.4.3 Calibration and Adjustment Using HM40..... 39
  - 5.4.4 Calibration and Adjustment Using MI70..... 44
  - 5.4.5 Adjusting Measurement Using Insight Software..... 46
- 5.5 Changing RFL100 Batteries..... 47
- 5.6 Changing RFL100 Clock Battery..... 48
- 5.7 Updating RFL100 Firmware..... 48
  
- 6. Troubleshooting.....50**
- 6.1 Problem Situations..... 50
- 6.2 Error Codes..... 51
- 6.3 Verifying Operation of RFL100..... 52
- 6.4 Downloading Data Using Service Port..... 52
- 6.5 Performing a Factory Reset..... 53
  
- 7. Technical Data.....54**
- 7.1 RFL100 Technical Specification..... 54
- 7.2 RFL100 Compatible Probes Technical Specification..... 56
- 7.3 Spare Parts and Accessories..... 59
- 7.4 Dimension Drawings..... 61
  
- Technical Support..... 65**
  
- Warranty..... 65**
  
- Recycling..... 65**

## List of Figures

Figure 1	Connecting RFL100 to the viewLinc Monitoring System.....	7
Figure 2	Front and Display.....	9
Figure 3	Under the Silicone Plug.....	9
Figure 4	Rear and Inside.....	10
Figure 5	Mounting Bracket.....	10
Figure 6	Alarm Indicators on RFL100 Display.....	12
Figure 7	RFL100 with High Alarm Active on Channel 1.....	13
Figure 8	RFL100 with High-High Alarm Active on Channel 1.....	14
Figure 9	RFL100 Mounting Methods.....	22
Figure 10	HMP110 Probe.....	24
Figure 11	HMP115 Probe.....	24
Figure 12	TMP115 Probe.....	25
Figure 13	RFL100 Remote Management using viewLinc Enterprise Server.....	28
Figure 14	RFL100 Properties in viewLinc.....	29
Figure 15	HMP115 Probe in Vaisala Insight Software.....	32
Figure 16	Connecting Probe to Insight.....	33
Figure 17	Adjusting Relative Humidity Measurement in Insight.....	46
Figure 18	RFL100 Dimensions with Mounting Bracket.....	61
Figure 19	RFL100 Dimensions without Mounting Bracket.....	61
Figure 20	RFL100 Mounting Bracket Dimensions.....	62
Figure 21	HMP110 Probe Dimensions.....	62
Figure 22	HMP115 Probe Dimensions.....	62
Figure 23	TMP115 Probe Dimensions.....	63

## List of Tables

Table 1	Document Versions (English).....	5
Table 2	Related Manuals.....	5
Table 3	Battery Level Indicator.....	11
Table 4	Alarm Symbols.....	12
Table 5	Specifications for a USB Power Supply.....	14
Table 6	Files and Folders in USB Filesystem.....	15
Table 7	Symbols Used in RFL100 Product Markings.....	20
Table 8	Symbols.....	25
Table 9	Connection States.....	26
Table 10	Troubleshooting Table.....	50
Table 11	RFL100 Error Codes.....	51
Table 12	Wireless.....	54
Table 13	Memory.....	54
Table 14	Operating Environment.....	55
Table 15	General.....	55
Table 16	Mechanical Specifications.....	55
Table 17	HMP110/T Probe Measurement Performance.....	56
Table 18	HMP115/T Probe Measurement Performance.....	57
Table 19	TMP115 Probe Measurement Performance.....	58
Table 20	HMP110 Probe Mechanical Specifications.....	58
Table 21	HMP115/T Probe Mechanical Specifications.....	59
Table 22	TMP115 Probe Mechanical Specifications.....	59
Table 23	RFL100 Spare Parts and Accessories.....	59
Table 24	HMP110/T Probe Spare Parts and Accessories.....	60
Table 25	HMP115/T Probe Spare Parts and Accessories.....	60
Table 26	TMP115 Probe Spare Parts and Accessories.....	60

# 1. About This Document

## 1.1 Version Information

This document provides instructions for installing, using, and maintaining the RFL100 Data Logger.

Table 1 Document Versions (English)

Document Code	Date	Description
M211861EN-C	February 2019	This document. Added TMP115 probe model. Updated Technical Data chapter and the following sections: <ul style="list-style-type: none"> <li>• <a href="#">Battery Level Indicator (page 11)</a></li> <li>• <a href="#">Calibration and Adjustment Using HM40 (page 39)</a></li> <li>• <a href="#">Updating RFL100 Firmware (page 48)</a></li> </ul> Added sections: <ul style="list-style-type: none"> <li>• <a href="#">Files and Folders in USB Filesystem (page 15)</a></li> <li>• <a href="#">Replacing the Probe (page 35)</a></li> <li>• <a href="#">Vaisala Insight Software (page 32)</a></li> <li>• <a href="#">Adjusting Measurement Using Insight Software (page 46)</a></li> <li>• <a href="#">Performing a Factory Reset (page 53)</a></li> </ul>
M211861EN-B	July 2018	Previous version. Added sections <a href="#">Probe Interface (page 8)</a> and <a href="#">Releasing RFL100 from viewLinc Monitoring System (page 29)</a> .
M211861EN-A	May 2018	First version.

## 1.2 Related Manuals

Table 2 Related Manuals

Document Code	Name
M211822EN	<i>RFL100 Data Logger Quick Guide</i>
M211821EN	<i>API0 Access Point Quick Guide</i>
M211860EN	<i>API0 Access Point User Guide</i>
M211820EN	<i>viewLinc Monitoring System Setup Guide</i>
M211975EN	<i>viewLinc Enterprise Server User Guide</i>

## 1.3 Documentation Conventions



**WARNING! Warning** alerts you to a serious hazard. If you do not read and follow instructions carefully at this point, there is a risk of injury or even death.



**CAUTION! Caution** warns you of a potential hazard. If you do not read and follow instructions carefully at this point, the product could be damaged or important data could be lost.



**Note** highlights important information on using the product.



**Tip** gives information for using the product more efficiently.



Lists tools needed to perform the task.



Indicates that you need to take some notes during the task.

## 1.4 Trademarks

Vaisala® and HUMICAP® are registered trademarks of Vaisala Oyj.

The LoRa™ name and associated logo are trademarks of Semtech Corporation or its subsidiaries.

All other product or company names that may be mentioned in this publication are trade names, trademarks, or registered trademarks of their respective owners.



## 2. Product Overview

### 2.1 RFL100 Overview

Vaisala RFL100 Data Logger is a completely wireless, battery powered data logger. It supports several types of Vaisala humidity and temperature measurement probes. RFL100 is intended as a data collection point in a Vaisala viewLinc Monitoring System.

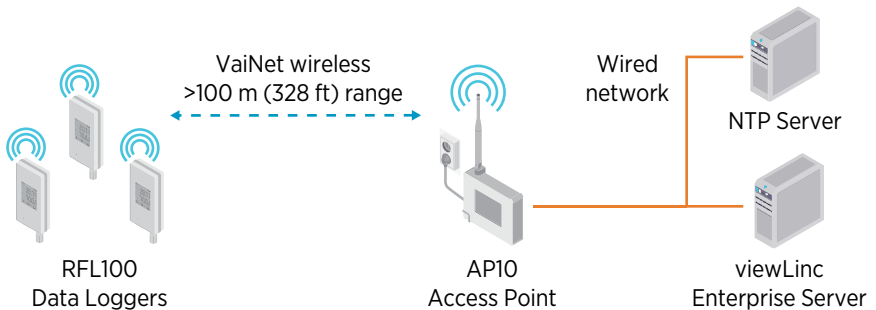

Figure 1 Connecting RFL100 to the viewLinc Monitoring System

The wireless connection of RFL100 requires a Vaisala AP10 Access Point. AP10 can connect up to 32 loggers to the viewLinc Monitoring System, and you can have up to 8 access points in range of each other. In a typical indoor space, install the AP10 within 100 meters (328 ft) of the RFL100. In an open space with line-of-sight and no interfering structures, the range can be over 500 m (1640 ft). The wireless connection operates on 868 MHz or 915 MHz frequency band depending on the model.

RFL100 is optimized for low power operation. It reads the probe once a minute, and transmits measurement data to the access point every four minutes. Because the radio link is not continuous, remote management actions and system joining status may take some time to be updated on the display of the data logger.



Before you start installing RFL100 Data Loggers, install the viewLinc Enterprise Server and at least one AP10 Access Point within range of RFL100. This way RFL100 can immediately discover your access point and join your system. For more information on viewLinc Monitoring System installation, see *viewLinc Setup Guide (M211820EN)*.

#### More Information

- [RFL100 Technical Specification \(page 54\)](#)

## 2.1.1 Probe Interface

The interface between RFL100 and its detachable probe is digital. RFL100 reads the measurement results from the probe and stores them in its own memory using the following resolution:

- RH is stored with resolution of 0.1 %RH
- T is stored with resolution of 0.05 K

Storing the measurement samples using this optimized resolution allows smaller storage size and faster transfer speed. The same resolution is used when the samples are sent and stored to viewLinc Enterprise Server.



Local display of RFL100 shows the latest measurements using one decimal place. This does not affect the internal resolution of temperature measurement in any way.

The detachable probe also contains its own identifying information (such as serial number) and information about its latest calibration (calibration date and information text string). RFL100 makes this information available to viewLinc. If the probe is replaced or the calibration information is changed, the information in viewLinc is automatically updated.

## 2.2 RFL100 Parts

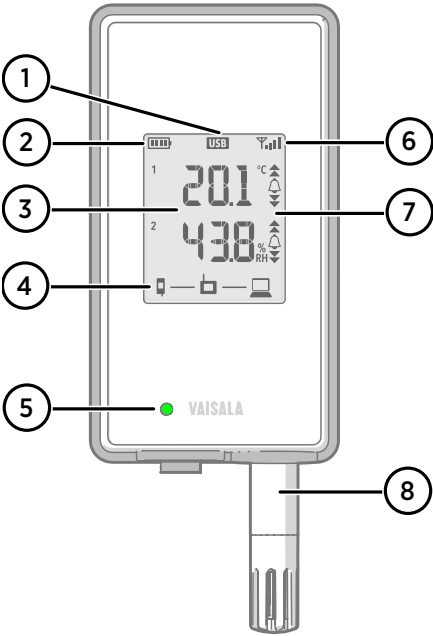

Figure 2 Front and Display

- 1 Service port connection indicator
- 2 Battery level indicator
- 3 Currently measured values
- 4 Connection indicators
- 5 Status LED. Blinks green for normal operation, red for error or alarm.
- 6 Signal strength of access point connection
- 7 Alarm indicators. Alarms are configured in viewLinc Enterprise Server software.
- 8 Detachable probe or probe cable

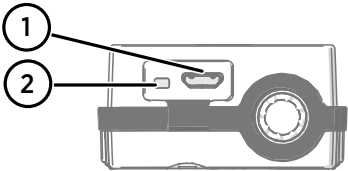

Figure 3 Under the Silicone Plug

- 1 Service port (Micro-USB)
- 2 **Refresh** button. Push to enable a faster wireless scanning interval for one hour. Also wakes up the display if it has been turned off remotely, and shows firmware version and currently connected VaiNet channel.

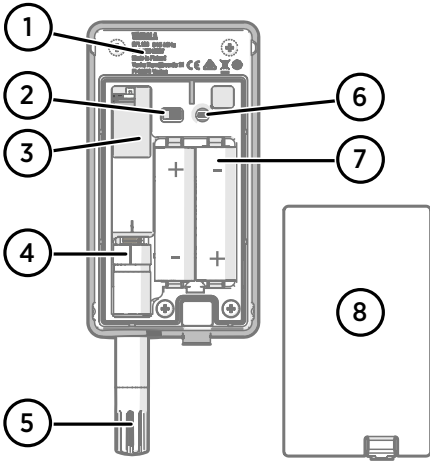

Figure 4 Rear and Inside

- 1 Type label
- 2 On/off switch
- 3 Clock battery
- 4 Probe orientation mark. When connecting the probe, line up the markings on the probe and above the connector before pushing the probe to the connector.
- 5 Humidity and/or temperature sensors under the filter
- 6 **Release** button. Push to release RFL100 from its current viewLinc system, and allow it to connect to any viewLinc system.
- 7 Main batteries. Use only non-rechargeable, AA size, 1.5 V alkaline (LR6) or lithium (FR6) batteries.
- 8 Battery cover

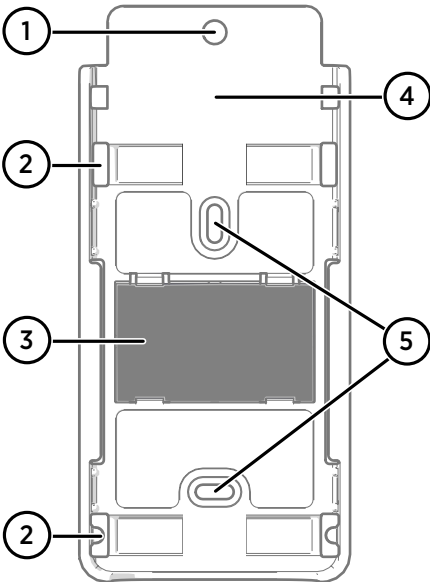

Figure 5 Mounting Bracket

- 1 6 mm (0.23 inch) hole for hook mounting
- 2 Holes for mounting with zip ties
- 3 Strong magnet (in magnetic mounting bracket only). **Handle with care.**
- 4 Suitable area for attaching labels
- 5 3.80 mm (0.15 inch) holes for screw mounting

## 2.3 RFL100 Batteries

### Main Batteries

RFL100 Data Logger is powered by two AA size primary (non-rechargeable) batteries with 1.5 V nominal voltage. Operation of the data logger always requires that compatible batteries with sufficient voltage are in place. When replacing batteries, always use new batteries, not partially discharged ones. Minimum battery voltage for operation is 2.15 V in series.

Compatible battery types are:

- 1.5 V alkaline batteries, designation IEC-LR6, ANSI 15A. Standard choice for most applications.
- 1.5 V lithium batteries, designation IEC-FR14505 (FR6), ANSI 15-LF. Typically higher capacity, better in cold temperatures.



**CAUTION!** Do not use batteries with a nominal voltage higher than 1.5 V.



Use of rechargeable batteries is not recommended. RFL100 will not charge batteries even if the service port is connected to a power supply.



### Clock Battery



RFL100 also has a separate 3 V lithium battery (type CR1/3N button cell) to keep the real-time clock powered when the device is otherwise turned off. This battery is good for 10 years, and should only be replaced if the data logger display shows the low clock battery error code **Err 200**.

#### 2.3.1 Battery Level Indicator

Battery level indicator displays an estimate of the capacity remaining in the main batteries of the data logger. It is based on typical behavior of alkaline batteries in this application.

Table 3 Battery Level Indicator

Symbol on Display	Description
	Full batteries.
	One quarter of battery capacity used.
	Half of the battery capacity used.

Symbol on Display	Description
	Low battery alarm is activated by viewLinc at this level. Remaining battery capacity is typically enough for 2 ... 4 weeks of normal operation. Replace batteries.
	Battery voltage is too low to support radio communication. Data logging continues locally for 2 ... 4 weeks until battery voltage is too low. The last bar of the battery symbol is flashing and error code <b>Err 103</b> is shown on the display. Replace batteries immediately.
	Battery voltage is too low for operation. Data logging is stopped. Only the empty battery symbol is shown on the display. Replace batteries to resume normal operation.

## 2.4 Alarm Indicators

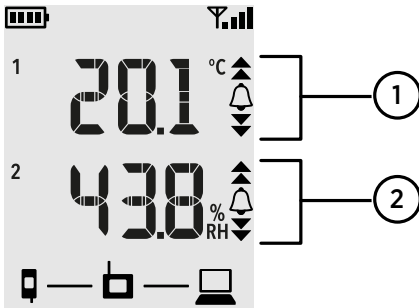







Figure 6 Alarm Indicators on RFL100 Display

- 1 Alarm indicators for channel 1
- 2 Alarm indicators for channel 2

Table 4 Alarm Symbols

Symbol on Display	Description
	High-high threshold alarm active.
	High threshold alarm active.
	Alarm bell symbol that is always shown when any threshold alarm is active on this channel.
	Low threshold alarm active.

Symbol on Display	Description
	Low-low threshold alarm active.

RFL100 can show active threshold alarms on its local display. When a threshold alarm is active on RFL100, the appropriate alarm indicators will be shown on the display. Additionally, the LED will flash red for high-high and low-low threshold alarms.

Threshold alarms cannot be configured locally on the RFL100 itself; they are configured using viewLinc Enterprise Server software. When applying a threshold alarm template to a Location, you can choose to show the alarms on the data logger that is linked to the location. To show the alarms, enable the **Send to device** setting, and then enable **Alarm on Device** for each threshold that you want to generate an alarm on the RFL100.

On the RFL100, only one set of thresholds can be active at a time for one channel. The latest set that is pushed to the device replaces the previous one. The **Send to device** setting of any previously sent threshold alarm is automatically set to **No**.

 RFL100 does not implement the **Alarm Delay** and **Alarm off margin** settings of viewLinc threshold alarms. Local alarm status on RFL100 changes as soon as the measured values cross the thresholds.

### 2.4.1 Alarm Examples



Figure 7 RFL100 with High Alarm Active on Channel 1



Figure 8 RFL100 with High-High Alarm Active on Channel 1

## 2.5 Service Port

The service port of the data logger provides a local interface for performing service actions that cannot be done over the air, such as updating the device firmware. The service actions are based on file transfer using Media Transfer Protocol (MTP), so no special software is needed. The service port connector is a standard micro-USB connector.

The service port can be used to supply operating power to the data logger. Use a power supply that fulfills the requirements listed in [Table 5 \(page 14\)](#).

Table 5 Specifications for a USB Power Supply

Property	Specification
Output voltage	5 VDC
Output current	min. 100 mA
Output connector	Micro-USB
Certifications and approvals	<ul style="list-style-type: none"> <li>• Certified to IEC 60950-1 or IEC 62368-1</li> <li>• Approved for use in your country</li> </ul>

Batteries with a sufficient voltage must always be in place inside the data logger, even when supplying external power through the service port.



**CAUTION!** When using an external power supply, the main batteries will be drained very slowly. As alkaline batteries may leak when left in place for a long time, always use compatible 1.5 V lithium batteries instead of alkaline batteries when using an external power supply.



## 2.5.1 Files and Folders in USB Filesystem

Following files and folders are present in the USB filesystem of the data logger. Vaisala support may request files from the data logger to help with solving your support request.

Except for the `\Data\Update\` folder that is used to load the firmware update file, the filesystem is read-only.

Table 6 Files and Folders in USB Filesystem

File or Folder	Content
<code>\Data\Licenses.zip</code>	Contains the licenses and notices for open source software used in this product.
<code>\Data\Configuration\Diagnostics.txt</code>	Summary of error code activations.
<code>\Data\Configuration\Parameters.json</code>	Configuration parameters of the data logger.
<code>\Data\Configuration\State.json</code>	Current time and state flags of the data logger.
<code>\Data\Configuration\Version.json</code>	Product code and firmware version of the data logger.
<code>\Data\Log\EventLog.txt</code>	Event history for the data logger.
<code>\Data\Log\Log_1h.txt</code>	Measurement data from the past hour.
<code>\Data\Log\Log_24h.txt</code>	Measurement data from the past 24 hours.
<code>\Data\Log\Log_30d.txt</code>	Measurement data from the past 30 days.
<code>\Data\Update\</code>	Folder for firmware update. Copy the firmware update file here to start the update.

## 2.6 Data Transfer in a VaiNet Network

VaiNet protocol and VaiNet devices are designed for power-efficient operation. To save energy VaiNet network transfers data at set intervals, which may be apparent to the user as longer data transfer times before the data is available on viewLinc Monitoring System.

## Intermittent Radio Connections

Access points take turns communicating in a two-minute cycle, and connected data loggers send their measurement data to their connected access point every four minutes. This introduces the following scenarios:

- Data loggers that are not currently connected (new devices or ones that have fallen out of radio contact) scan for available access points for a complete cycle before they can decide what is the optimal access point for them. Connection attempts typically take at least a couple of minutes. Additionally, some joining scenarios may take multiple attempts. For example, when filling a single access point up to its full capacity of 32 data loggers, it may take an hour for the last data logger to successfully connect to the access point.
- Access points request missing data and issue management commands to data loggers within their communication window. Transferring a full month's worth of measurement data from 32 data loggers using one access point takes several hours.

## Data Logger Scanning Interval

Scanning for available access points consumes power. To prevent repeated scanning from draining their batteries, RFL100 Data Loggers shut down their radio temporarily if they can find no access points to join. They will resume scanning after a waiting interval that gets progressively longer if they keep failing to find an access point. The maximum interval is 8 hours and 30 minutes.

This means that when access points become available after an outage, it may take several hours for data loggers to discover them. This is why you should always keep your access points powered up, and why you should start your network installation by installing the viewLinc Enterprise Server and access points first.



You can manually wake up the radio of an RFL100 Data Logger by pressing its **Refresh** button. The button is located next to the service port under the silicone plug.

## 2.7 Regulatory Compliance

### 2.7.1 FCC Compliance Statement

This equipment has been tested and found to comply with the limits for a Class A digital device, pursuant to part 15 of the FCC Rules. These limits are designed to provide reasonable protection against harmful interference when the equipment is operated in a commercial environment. This equipment generates, uses, and can radiate radio frequency energy and, if not installed and used in accordance with the instruction manual, may cause harmful interference to radio communications. Operation of this equipment in a residential area is likely to cause harmful interference in which case the user will be required to correct the interference at his own expense.



**WARNING!** Changes or modifications to this equipment not expressly approved by the party responsible for compliance could void the user's authority to operate the equipment.



**WARNING!** This device complies with part 15 of the FCC Rules. Operation is subject to the following two conditions: (1) This device may not cause harmful interference, and (2) this device must accept any interference received, including interference that may cause undesired operation.

## 2.7.2 ISED Compliance Statement

This device complies with Industry Canada licence-exempt RSS standard(s). Operation is subject to the following two conditions:

1. This device may not cause interference; and
2. This device must accept any interference, including interference that may cause undesired operation of the device.

This device has a PCB integrated inverted F-antenna with a gain of 1 dBi.

Le présent appareil est conforme aux CNR d'Industrie Canada applicables aux appareils radio exempts de licence. L'exploitation est autorisée aux deux conditions suivantes:

1. l'appareil ne doit pas produire de brouillage, et
2. l'utilisateur de l'appareil doit accepter tout brouillage radioélectrique subi, même si le brouillage est susceptible d'en compromettre le fonctionnement.

Le présent appareil dispose d'une antenne F inversée intégrée à la carte avec un gain de 1 dBi.



**CAUTION!** This device requires a separation distance of at least 20 cm. This distance must be maintained between the user and the device when the device is operating.



**CAUTION!** Cet appareil nécessite une distance de séparation d'au moins 20 cm. Cette distance doit être maintenue entre l'utilisateur et l'appareil lorsque l'appareil est en fonctionnement.

## 2.7.3 EU Declaration of Conformity

**BG:** С настоящото Vaisala Oyj декларира, че този тип радиосъоръжение RFL100 е в съответствие с Директива 2014/53/ЕС. Цялостният текст на ЕС декларацията за съответствие може да се намери на следния интернет адрес: [www.vaisala.com/declarationofconformity](http://www.vaisala.com/declarationofconformity)

**CS:** Tímto Vaisala Oyj prohlašuje, že typ rádiového zařízení RFL100 je v souladu se směrnicí 2014/53/EU. Úplné znění EU prohlášení o shodě je k dispozici na této internetové adrese: [www.vaisala.com/declarationofconformity](http://www.vaisala.com/declarationofconformity)

**DA:** Hermed erklærer Vaisala Oyj , at radioudstyrstypen RFL100 er i overensstemmelse med direktiv 2014/53/EU. EU-overensstemmelseserklæringens fulde tekst kan findes på følgende internetadresse: [www.vaisala.com/declarationofconformity](http://www.vaisala.com/declarationofconformity)

**DE:** Hiermit erklärt Vaisala Oyj , dass der Funkanlagentyp RFL100 der Richtlinie 2014/53/EU entspricht. Der vollständige Text der EU-Konformitätserklärung ist unter der folgenden Internetadresse verfügbar: [www.vaisala.com/declarationofconformity](http://www.vaisala.com/declarationofconformity)

**EL:** Με την παρούσα ο/η Vaisala Oyj , δηλώνει ότι ο ραδιοεξοπλισμός RFL100 πληροί την οδηγία 2014/53/ΕΕ. Το πλήρες κείμενο της δήλωσης συμμόρφωσης ΕΕ διατίθεται στην ακόλουθη ιστοσελίδα στο διαδίκτυο: [www.vaisala.com/declarationofconformity](http://www.vaisala.com/declarationofconformity)

**EN:** Hereby, Vaisala Oyj declares that the radio equipment type RFL100 is in compliance with Directive 2014/53/EU. The full text of the EU declaration of conformity is available at the following internet address: [www.vaisala.com/declarationofconformity](http://www.vaisala.com/declarationofconformity)

**ES:** Por la presente, Vaisala Oyj declara que el tipo de equipo radioeléctrico RFL100 es conforme con la Directiva 2014/53/UE. El texto completo de la declaración UE de conformidad está disponible en la dirección Internet siguiente: [www.vaisala.com/declarationofconformity](http://www.vaisala.com/declarationofconformity)

**ET:** Käesolevaga deklareerib Vaisala Oyj , et käesolev raadioseadme tüüp RFL100 vastab direktiivi 2014/53/EL nõuetele. ELi vastavusdeklaratsiooni täielik tekst on kättesaadav järgmisel internetiaadressil: [www.vaisala.com/declarationofconformity](http://www.vaisala.com/declarationofconformity)

**FI:** Vaisala Oyj vakuuttaa, että radiolaitetyyppi RFL100 on direktiivin 2014/53/EU mukainen. EU-vaatimustenmukaisuusvakuutuksen täysimittainen teksti on saatavilla seuraavassa internetosoitteessa: [www.vaisala.com/declarationofconformity](http://www.vaisala.com/declarationofconformity)

**FR:** Le soussigné, Vaisala Oyj , déclare que l'équipement radioélectrique du type RFL100 est conforme à la directive 2014/53/UE. Le texte complet de la déclaration UE de conformité est disponible à l'adresse internet suivante: [www.vaisala.com/declarationofconformity](http://www.vaisala.com/declarationofconformity)

**HR:** Vaisala Oyj ovime izjavljuje da je radijska oprema tipa RFL100 u skladu s Direktivom 2014/53/EU. Cjeloviti tekst EU izjave o sukladnosti dostupan je na sljedećoj internetskoj adresi: [www.vaisala.com/declarationofconformity](http://www.vaisala.com/declarationofconformity)

**HU:** Vaisala Oyj igazolja, hogy a RFL100 típusú rádióberendezés megfelel a 2014/53/EU irányelvnek. Az EU-megfelelőségi nyilatkozat teljes szövege elérhető a következő internetes címen: [www.vaisala.com/declarationofconformity](http://www.vaisala.com/declarationofconformity)

**IT:** Il fabbricante, Vaisala Oyj , dichiara che il tipo di apparecchiatura radio RFL100 è conforme alla direttiva 2014/53/UE. Il testo completo della dichiarazione di conformità UE è disponibile al seguente indirizzo Internet: [www.vaisala.com/declarationofconformity](http://www.vaisala.com/declarationofconformity)

**LT:** Aš, Vaisala Oyj , patvirtinu, kad radijo įrenginių tipas RFL100 atitinka Direktyvą 2014/53/ES. Visas ES atitikties deklaracijos tekstas prieinamas šiuo interneto adresu: [www.vaisala.com/declarationofconformity](http://www.vaisala.com/declarationofconformity)

**LV:** Ar šo Vaisala Oyj deklarē, ka radioiekārta RFL100 atbilst Direktīvai 2014/53/ES. Pilns ES atbilstības deklarācijas teksts ir pieejams šādā interneta vietnē: [www.vaisala.com/declarationofconformity](http://www.vaisala.com/declarationofconformity)

**MT:** B'dan, Vaisala Oyj , niddikjara li dan it-tip ta' tagħmir tar-radju RFL100 huwa konformi mad-Direttiva 2014/53/UE. It-test kollu tad-dikjarazzjoni ta' konformità tal-UE huwa disponibbli f'dan l-indirizz tal-Internet li ġej: [www.vaisala.com/declarationofconformity](http://www.vaisala.com/declarationofconformity)

**NL:** Hierbij verklaar ik, Vaisala Oyj , dat het type radioapparatuur RFL100 conform is met Richtlijn 2014/53/EU. De volledige tekst van de EU-conformiteitsverklaring kan worden geraadpleegd op het volgende internetadres: [www.vaisala.com/declarationofconformity](http://www.vaisala.com/declarationofconformity)

**PL:** Vaisala Oyj niniejszym oświadcza, że typ urządzenia radiowego RFL100 jest zgodny z dyrektywą 2014/53/UE. Pełny tekst deklaracji zgodności UE jest dostępny pod następującym adresem internetowym: [www.vaisala.com/declarationofconformity](http://www.vaisala.com/declarationofconformity)

**PT:** O(a) abaixo assinado(a) Vaisala Oyj declara que o presente tipo de equipamento de rádio RFL100 está em conformidade com a Diretiva 2014/53/UE. O texto integral da declaração de conformidade está disponível no seguinte endereço de Internet: [www.vaisala.com/declarationofconformity](http://www.vaisala.com/declarationofconformity)

**RO:** Prin prezenta, Vaisala Oyj declară că tipul de echipamente radio RFL100 este în conformitate cu Directiva 2014/53/UE. Textul integral al declarației UE de conformitate este disponibil la următoarea adresă internet: [www.vaisala.com/declarationofconformity](http://www.vaisala.com/declarationofconformity)

**SK:** Vaisala Oyj týmto vyhlasuje, že rádiové zariadenie typu RFL100 je v súlade so smernicou 2014/53/EÚ. Úplné EÚ vyhlásenie o zhode je k dispozícii na tejto internetovej adrese: [www.vaisala.com/declarationofconformity](http://www.vaisala.com/declarationofconformity)

**SL:** Vaisala Oyj potrjuje, da je tip radijske opreme RFL100 skladen z Direktivo 2014/53/EU. Celotno besedilo izjave EU o skladnosti je na voljo na naslednjem spletnem naslovu: [www.vaisala.com/declarationofconformity](http://www.vaisala.com/declarationofconformity)

**SV:** Härmed försäkrar Vaisala Oyj att denna typ av radioutrustning RFL100 överensstämmer med direktiv 2014/53/EU. Den fullständiga texten till EU-försäkran om överensstämmelse finns på följande webbadress: [www.vaisala.com/declarationofconformity](http://www.vaisala.com/declarationofconformity)

## 2.7.4 UAE Compliance

TRA  
Registered No: ER67584/18  
Dealer No: DA78828/18









## 2.8 Safety



**CAUTION!** The optional magnetic mounting bracket of the RFL100 has a strong magnet. Handle it with care and keep it away from devices that are sensitive to magnetic fields (for example, pacemakers, magnetic cards, and mechanical watches.)

## 2.9 Symbols in RFL100 Product Markings

Table 7 Symbols Used in RFL100 Product Markings

Symbol	Description
	Meets the essential requirements of the applicable EC directives
	Symbol of electrical and electronic equipment according to the WEEE directive
	FCC mark
	Environment Friendly Use Period of 10 years
	Read user instructions
	Read user instructions
	Battery orientation symbol
	Regulatory Compliance Mark (RCM)

## 2.10 ESD Protection

Electrostatic Discharge (ESD) can cause immediate or latent damage to electronic circuits. Vaisala products are adequately protected against ESD for their intended use. However, it is possible to damage the product by delivering an electrostatic discharge when touching, removing or inserting any objects inside the equipment housing.

Avoid touching component contacts or connectors when working with the device.

## 3. Installation

### 3.1 Setting Up RFL100 Data Logger

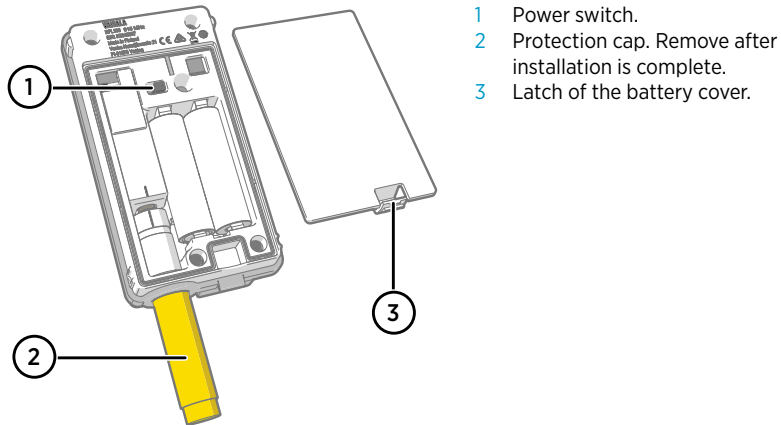

- 1 Power switch.
- 2 Protection cap. Remove after installation is complete.
- 3 Latch of the battery cover.

- ▶ 1. Open the battery cover of the data logger.
2. Move the power switch to the **On** position.
3. Close the battery cover of the data logger. **Push the latch down until you hear a click.** If the cover does not close easily, push the probe (or the probe cable) in and try again.
4. Look at the display and verify that:
  - Battery indicator shows full batteries .
  - Display shows measurement readings instead of dashes or error codes.

If measurement readings are not shown after a few seconds, check that the probe is properly connected. It is possible to disconnect the probe by pulling on the probe with the battery cover open. In that case the display will show error code **Err 202**.



When you turn on the RFL100 it starts to scan for VaiNet access points that are in installation mode. RFL100 will connect to the access point with the best signal strength, and wait to be accepted by the administrator of the viewLinc Enterprise Server.

## 3.2 Mounting RFL100

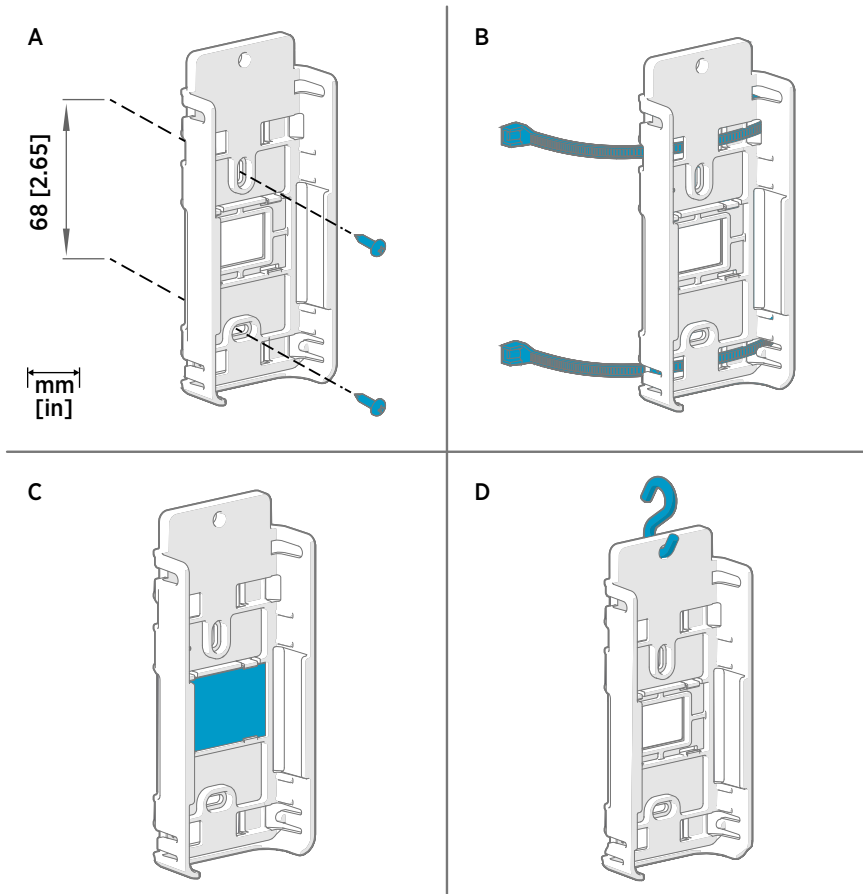

Figure 9 RFL100 Mounting Methods

- A Mounting with screws. Screws and wall plugs are included with the data logger.
- B Mounting with zip ties. Zip ties are included with the data logger.
- C Magnetic mounting (with optional magnetic mounting bracket)
- D Mounting with a hook (hook not included)



- ▶ 1. Select a suitable mounting location. A good location is easily accessible, protected from water and condensation, and remains within the operating temperature range of RFL100:
  - +2 ... +60 °C (+35.6 ... +140 °F) with alkaline batteries
  - -20 ... +60 °C (-4 ... +140 °F) with lithium batteries



If you need to measure a wider temperature range, use a HMP110 or TMP115 probe and connect it using a cable. This way you can leave the data logger in an environment that is suitable to its specification.

2. Attach the mounting bracket using one of the mounting methods shown in [Figure 9](#) (page 22). Orient the bracket vertically so that the probe or probe cable points down after installation. Do not attach RFL100 without the mounting bracket.



**CAUTION!** If you are mounting the data logger higher than 2 m (6 ft) or in a location where it would pose a hazard if dropped, ensure the mounting bracket is securely fixed with screws or zip ties.

3. Slide the logger into the mounting bracket with the probe or probe cable pointing downward.
4. Peel off the protective film from the display and remove the yellow plug from the probe.

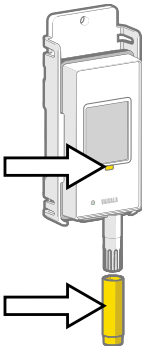

5. If the probe is attached with a cable, mount the probe in the desired measurement location and secure the cable.
6. Recommended: Apply location labels to the mounting bracket and RFL100 according to your installation plan and company policy.

### 3.2.1 Mounting HMP110 Probes

Robust stainless steel probe for humidity and temperature measurement in demanding conditions. Suitable for measurement inside chambers, fridges, and freezers in temperature range  $-40 \dots +80 \text{ }^{\circ}\text{C}$  ( $-40 \dots +176 \text{ }^{\circ}\text{F}$ ). Must be connected using a cable - the probe is not designed to be integrated with RFL100 housing. Probe diameter 12 mm (0.47 in).

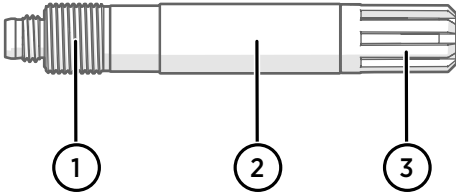

Figure 10 HMP110 Probe

- 1 M12x1 thread for mounting the probe in a through-wall installation using mounting nuts.
- 2 Attach from this area if using mounting clamps or zip ties.
- 3 Sensor protection filter. Do not attach from this area.

### 3.2.2 Mounting HMP115 Probes

Probe for general purpose humidity and temperature measurement. Designed to be integrated with RFL100 housing for minimum footprint, but can be connected using a cable as well. Operating temperature range  $-40 \dots +60 \text{ }^{\circ}\text{C}$  ( $-40 \text{ }^{\circ}\text{F} \dots +140 \text{ }^{\circ}\text{F}$ ).

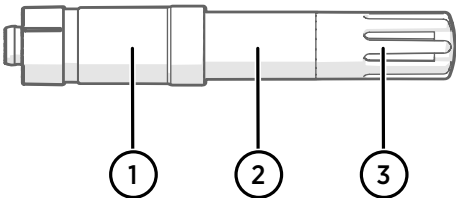

Figure 11 HMP115 Probe

- 1 Plastic sleeve that locks the probe in place when integrated with RFL100. Diameter 14 mm (0.55 in) at this point.
- 2 Attach from this area using mounting clamps or zip ties. Diameter 12 mm (0.47 in) at this point.
- 3 Sensor protection filter. Do not attach from this area.

### 3.2.3 Mounting TMP115 Probes

Wide-range temperature-only probe for measurement in extreme conditions. Probe body can be integrated with RFL100 or connected using a cable. Sensor tip is permanently connected to the probe body with a thin cable. Available as 50 cm (1 ft 7.7 in) and 3 m (9.8 ft) long versions.

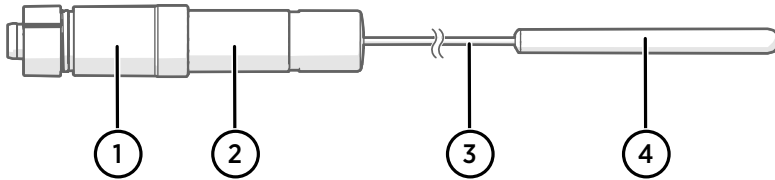

Figure 12 TMP115 Probe

- 1 Plastic sleeve that locks the probe body in place when integrated with RFL100. Diameter 14 mm (0.55 in) at this point.
- 2 Probe body with measurement electronics. Diameter 12 mm (0.47 in) at this point. Operating temperature range -40 ... +60 °C (-40 ... +140 °F).
- 3 Sensor cable. Do not cut or bend into a tight loop.
- 4 Sensor tip, diameter 4.8 mm (0.19 in). Secure using a zip tie or insert into thermal dampener block for added thermal mass. Operating temperature range -196 ... +90 °C (-320.8 ... +194 °F).



**CAUTION!** The operating temperature range of the sensor tip is much wider than that of the probe body. Leave the probe body outside the measured environment if possible, and avoid inserting it in environments that are outside its operating range.



When working with equipment in extremely cold temperatures, use appropriate personal protective equipment such as thermally insulated gloves and clothing. Wear protective eyewear if working with coolants such as liquid nitrogen, and observe safe handling and storage precautions.

## 3.3 Connection Indicators

Table 8 Symbols

Symbol	Description	Symbol	Description
	Data logger		Connection OK













Symbol	Description	Symbol	Description
	Access point		Connection currently unavailable
	viewLinc Enterprise Server		

Table 9 Connection States

Symbols on Display	Description
	Data logger is searching for an access point.
	Data logger has failed to find an access point that is in installation mode. viewLinc server icon is not shown, as the data logger has not been accepted to a viewLinc system yet.
	The data logger has failed to connect to an access point that belongs to its own network.
	Data logger is successfully connected to an access point, but there is no connection between the access point and viewLinc server. Data logger has not been accepted to a viewLinc system yet.
	Data logger is successfully connected to an access point, but there is no connection between the access point and viewLinc server. Data logger has been accepted to a viewLinc system.
	Data logger is successfully connected to an access point, and connection between the access point and viewLinc server is also OK. The viewLinc symbol is flashing to indicate that the data logger is waiting to be accepted to the viewLinc system as a new device.
	Data logger is successfully connected to an access point, and connection between the access point and viewLinc server is also OK. Data logger has been accepted to the viewLinc system.

### 3.3.1 Connection Examples

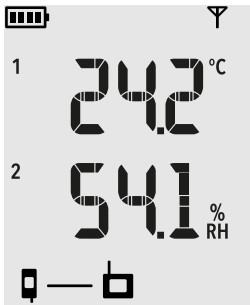

**Looking for an access point to join:** Line between data logger  and access point  symbols is blinking, and signal strength indicator shows no bars.



**Connected to an access point but viewLinc Enterprise Server not discovered yet:** Signal strength indicator  shows the strength of the access point connection.

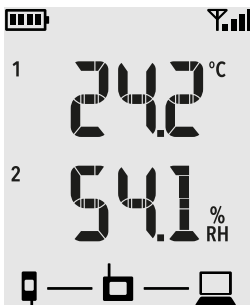

**Full connectivity:** Data logger has discovered a viewLinc Enterprise Server and is connected to it through the access point. You can now log in to the viewLinc Enterprise Server and accept the device to the system.

# 4. Operation

## 4.1 Remote Management

After a RFL100 Data Logger has been accepted to a viewLinc Monitoring System, it can be remotely managed using viewLinc Enterprise Server software. Remote management operations can be performed directly from the **Sites Manager > Hosts and Devices** tree.

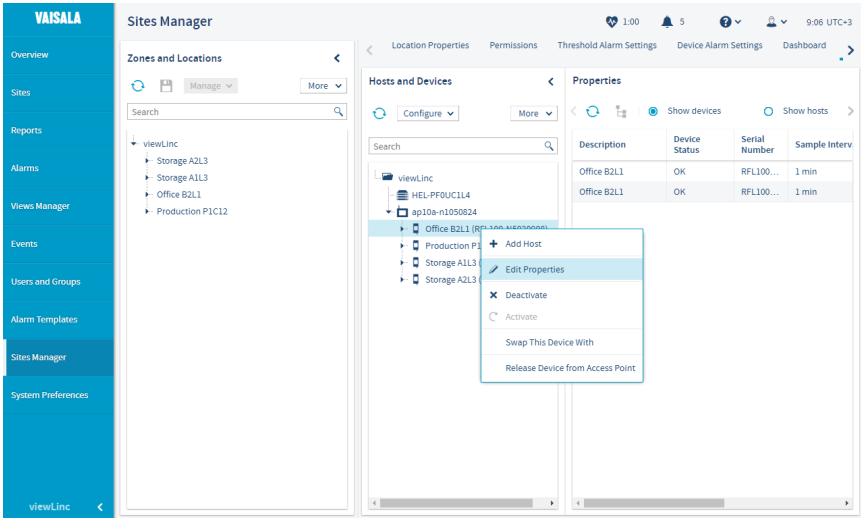

Figure 13 RFL100 Remote Management using viewLinc Enterprise Server

Select **Configure > Edit Properties** to access the remotely configurable settings.

### Edit Device Properties

Property	Value
Host	ap10a-n1050824
Device class	RFL Data Logger
Hardware model	RFL100
Serial number	RFL100-N5020908
Device alias	
Device description	Office B2L1
RFL LED	On
RFL display panel	On
Enable RFL non-metric units	No

When a channel calibration scale is modified, it is recommended that device calibration dates are updated.

#### Probe (N4950739)

Calibration date	12/13/2017
Calibrated by	Vaisala/HEL
Next calibration date	12/13/2018



Figure 14 RFL100 Properties in viewLinc

Local alarms on the RFL100 are also managed remotely, but in a different way. See [Alarm Indicators \(page 12\)](#).



viewLinc automatically issues calibration reminder notifications at 3 months and 1 month before to the due date, and again on the due date.

## 4.2 Releasing RFL100 from viewLinc Monitoring System

After RFL100 Data Logger has been accepted to a viewLinc Monitoring System by a viewLinc Enterprise Server administrator, it will not connect to any other system unless first released from its current system. There are two ways to release the logger:

- Locally by pressing its **Release** button
- Remotely from viewLinc Enterprise Server software



Measurement and data logging is not affected by the release procedure. Existing data will remain unaffected on the data logger. All remotely managed RFL100 settings will be reset to defaults: threshold alarm indicators will be cleared, and display and LED will turn on if they have been remotely turned off.

After RFL100 is released, it will be ready to join any compatible viewLinc Monitoring System after a delay of 4 ... 6 minutes. The connecting access point must be in installation mode.

## 4.2.1 Releasing Using Release Button



- Pen or a small screwdriver

- ▶ 1. Remove the data logger from the mounting bracket.
2. Open the battery cover of the data logger.
3. Press the **Release** button using a pen or a small screwdriver.
4. Verify from the display that the text **NWK REL** appears briefly, and that the connection icon that denotes the viewLinc Enterprise Server  disappears.



5. Close the battery cover of the data logger. **Push the latch down until you hear a click.** If the cover does not close easily, push the probe (or the probe cable) in and try again.
6. Insert the data logger back in the mounting bracket.

## 4.2.2 Releasing Remotely Using viewLinc

- ▶ 1. Log in to the viewLinc Enterprise Server with a user account that has the right to manage devices.
2. Select **Sites Manager > Hosts and Devices**.
3. Select the data logger you want to release from the **Hosts and Devices** tree.
4. Select **Configure > Release Device from Access Point**.



5. Select **Release** to confirm.

## 4.3 Speeding Up Radio Scanning Temporarily



- Pen or a small screwdriver

RFL100 has a small button next to the service port: the **Refresh** button. Pressing this button enables the following for one hour, after which the RFL100 returns to normal behavior:

- Display and LED are turned on if they have been turned off remotely.
- RFL100 starts radio scanning immediately if it has been shut down to save power.
- Firmware version of the RFL100 is shown on the screen, alternating with measurement results.
- If RFL100 is connected to an access point:
  - Signal strength indicator  is updated faster, approximately every 30 seconds.
  - Access point shows the currently connected VaiNet channel, alternating with measurement results and firmware version.

- ▶ 1. Open the plug that covers the service port.
2. Push the small button next to the service port using a pen or a small screwdriver.
3. Verify from the display that the text **INFO ON** appears briefly.
4. Close the plug over the service port.

## 4.4 Vaisala Insight Software



Figure 15 HMP115 Probe in Vaisala Insight Software

Vaisala Insight software is compatible with probes used by RFL100 data logger. With Insight software, you can:

- See probe information and status
- See real-time measurement
- Calibrate and adjust the probe
- Configure probe settings
- Monitor and record 2 measurement parameters up to 48 hours

Download Vaisala Insight software at [www.vaisala.com/insight](http://www.vaisala.com/insight). The supported operating systems are Windows 7 (64-bit), Windows 8.1 (64-bit), and Windows 10 (64-bit).

You need a Vaisala USB cable (order code 219690) to connect the probe to your computer.

### More Information

- [Adjusting Measurement Using Insight Software \(page 46\)](#)

### 4.4.1 Connecting Probe to Insight Software



Figure 16 Connecting Probe to Insight



- Computer with Vaisala Insight software installed
- USB connection cable (order code 219690)

- ▶ 1. Disconnect the probe from the data logger.
2. Open the Insight software.
3. Connect the USB cable to a free USB port on the PC.
4. Connect the probe to the USB cable.
5. Wait for Insight software to detect the probe.

#### More Information

- ▶ [Replacing the Probe \(page 35\)](#)

## 5. Maintenance

### 5.1 Cleaning RFL100



- Lint-free cloth
- Isopropyl alcohol (70 %)



Do not spray anything directly on the RFL100, since that may deposit impurities on the sensor.

- ▶ 1. Remove the data logger from the mounting bracket.
2. Moisten some lint-free cloth with isopropyl alcohol (70%).
3. Wipe the data logger and the mounting bracket.
4. Check the filter on the probe. If the filter becomes contaminated, it is very likely to affect the humidity measurement since residue on the filter will retain some moisture. If the filter is dirty, replace it with a new one. See [Changing the Probe Filter \(page 34\)](#).
5. Insert the data logger back in the mounting bracket.

### 5.2 Changing the Probe Filter



- New filter for the probe

Filter on the probe should be replaced when it is damaged or dirty. You can change the probe filter without disconnecting the probe from the data logger.



**CAUTION!** The sensors are easily damaged when the filter is not in place. Handle the probe carefully.

- ▶ 1. Turn the filter counter-clockwise to loosen it.
2. Remove the filter from the probe. Be careful not to touch the sensors with the filter.
3. Install a new filter on the probe, and tighten it so it is finger-tight. Make sure the filter sits straight and meets the thread properly.

**More Information**

- [Spare Parts and Accessories \(page 59\)](#)

## 5.3 Replacing the Probe

You can easily replace the probe of the RFL100 Data Logger with any compatible probe type. After a probe is replaced, the RFL100 communicates the new device information automatically to viewLinc Enterprise Server. This information includes the serial number and calibration information stored in the probe. Stored data points are automatically associated with the correct probe.

Probe replacement will cause a short break in data logging while RFL100 is turned off. To avoid any interruption to monitoring, use the **Swap Device** feature of viewLinc Enterprise Server to link another device to the monitored Location for the duration of probe replacement. See *viewLinc User Guide (M211975EN)*.



If you replace the probe with a different model that does not have the same measurement channels, make sure any missing channel is not linked to a Location in viewLinc. Adjust the viewLinc configuration as needed.

- ▶ 1. Remove the data logger from the mounting bracket.
2. Open the battery cover of the data logger.
3. Move the power switch to the **Off** position.

4. To replace a fixed probe (directly connected to RFL100 without a cable):

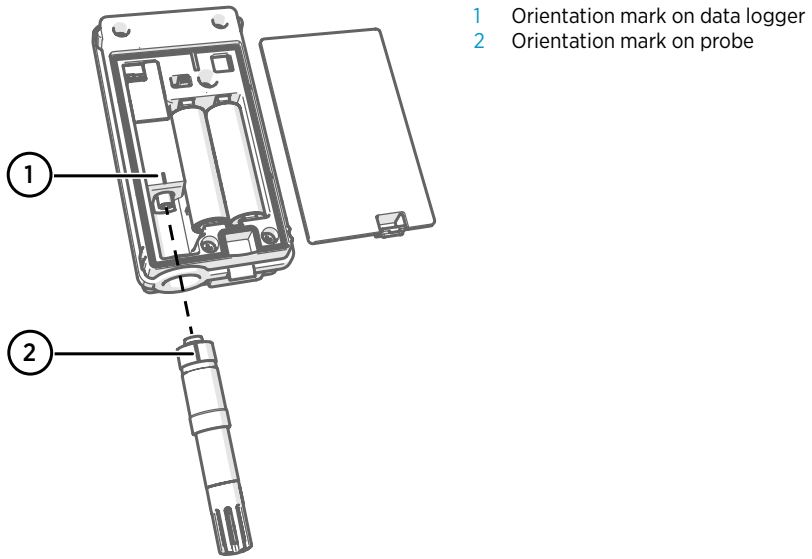

- a. Grip the old probe from above the filter and hold the data logger with your other hand. Pull the probe straight out of the data logger. Do not rotate the probe.
- b. Align the orientation mark on the new probe with the line above the probe connector. Push the probe straight in all the way, do not rotate.

5. To replace a cabled probe:

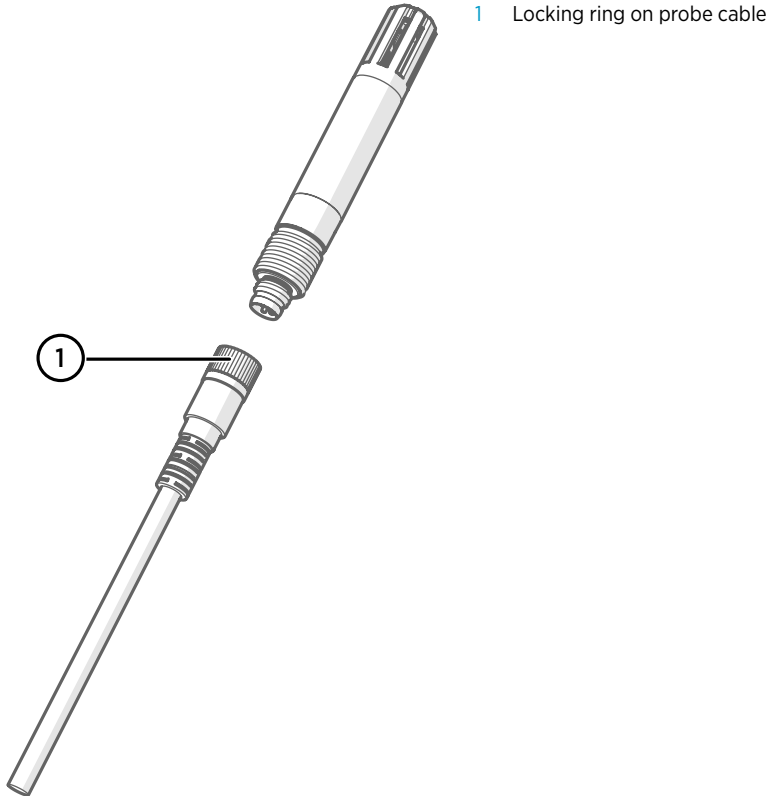

- a. Loosen the locking ring of the connector at the end of the probe cable, and pull the old probe away from the connector.
  - b. Connect the new probe and tighten the locking ring.
6. Move the power switch to the **On** position.
  7. Verify that the display shows measurement readings instead of dashes or error codes.
  8. Close the battery cover of the data logger. **Push the latch down until you hear a click.** If the cover does not close easily, push the probe (or the probe cable) in and try again.
  9. Insert the data logger back in the mounting bracket.

#### More Information

- [Error Codes \(page 51\)](#)

## 5.4 Calibration and Adjustment



If you think the device is not measuring correctly, calibration and adjustment is not the first thing to do. Check the following first:

- Make sure nothing is interfering with the measurement: heat sources, temperature differences, or condensation.
- Check that there is no moisture on the probe. If the sensor has become wet, wait for it to dry.
- Always wait for the measurement to stabilize.



**Calibration** means comparing the measurement output of the device to a known reference, such as a known environment in a calibration chamber or the output of a reference instrument. Correcting the reading of the device so that it measures accurately is referred to as **adjustment**.

Sensors and measurement electronics used by the data logger are fully contained in the replaceable probe. This allows the probe to be calibrated, adjusted, and replaced as needed. Probe serial number and calibration information (calibration date and information text string) are stored in the probe. If the probe is replaced or the calibration information in the probe is updated, RFL100 automatically sends the new information to viewLinc.

The calibration frequency depends on the application and your compliance requirements. Vaisala recommends having the probe calibrated and adjusted once a year by Vaisala Calibration and Repair Services. See [www.vaisala.com/calibration](http://www.vaisala.com/calibration).

Generic procedures for on-site calibration and adjustment are provided in this guide:

- To verify the measurement accuracy of the probe without disconnecting it from the data logger, compare its readings with a calibrated reference instrument. Doing this at the installation location of the data logger is referred to as a field check. See [Field Checking Using a Reference Instrument \(page 39\)](#).
- To calibrate and adjust the probe using a Vaisala handheld meter and humidity and temperature references, see [Calibration and Adjustment Using HM40 \(page 39\)](#) and [Calibration and Adjustment Using MI70 \(page 44\)](#).
- To calibrate and adjust the probe and change its stored calibration information using a computer, connect the probe to Vaisala Insight software. See [Adjusting Measurement Using Insight Software \(page 46\)](#).

### 5.4.1 Calibration and Adjustment Environments

Measurement probes can be **calibrated** in any environment that is within their operating range. For example, output from TMP115 probe can be checked and compared at any temperature in range -196 ... +90 °C (-320.8 ... +194 °F). However, probes should only be **adjusted** in conditions where they have good accuracy. Refer to the accuracy specification of the probe you intend to adjust. Probes will not accept the adjustment if the adjustment points are unsuitable.





When working with equipment in extremely cold temperatures, use appropriate personal protective equipment such as thermally insulated gloves and clothing. Wear protective eyewear if working with coolants such as liquid nitrogen, and observe safe handling and storage precautions.

#### More Information

- [RFL100 Technical Specification \(page 54\)](#)

### 5.4.2 Field Checking Using a Reference Instrument

You can perform a field check of the RFL100 using any humidity and temperature measurement instrument with a display. Typically field checking is done with a recently calibrated portable instrument.

- ▶ 1. Place the probe of the reference instrument (or the entire instrument) in the same environment as the probe of the RFL100. The environment should be as stable as possible.
2. Wait for 30 minutes for humidity and temperature to stabilize. Verify that measurements are no longer changing at the end of the stabilization period.
3. Record the readings from both instruments.

### 5.4.3 Calibration and Adjustment Using HM40



- Vaisala HM40 Hand-Held Humidity and Temperature Meter
- Connection cable for HM40 Hand-Held Meter (Vaisala item HMT120Z300)
- Reference environments for the desired calibration points
- RFL100 data logger with the probe to be calibrated

You can calibrate and adjust the probe of your RFL100 data logger in one or two points using the HM40. For a 2-point calibration, you need two reference environments. For example, LiCl and NaCl salt chambers provide 11% and 75% relative humidity references. Note that when performing a 2-point RH calibration, the first point requires a < 50% RH humidity reference, and the second point must be > 50% RH. The difference between the two humidity references must be at least 30% RH.

- ▶ 1. Disconnect the probe from the data logger.
2. Connect the probe to HM40 hand-held meter using the connection cable.
3. Turn on HM40 and check that measurements from the probe are displayed on the screen.
4. Select **Menu > Settings > Time & Date** and verify that the current time and date are set correctly on the HM40. Correct them if needed. The current date will be automatically set as the calibration date of the probe when adjustment is applied in [step 13](#).
5. Select **Menu > Calibration**.

6. Select the parameter to be calibrated at menu item **[1] Quantity**.

Calibration			
How to Calibrate			
<b>1</b>	<b>Quantity</b> RH [%RH]		
<b>2</b>	<b>Point count</b> 1		
<b>3</b>	<b>Point 1</b> —		
<b>4</b>	<b>Point 2</b> —		
<b>5</b>	<b>Note</b> **VAISA...		
<b>6</b>	<b>Apply</b>		
<table border="0"> <tr> <td><b>Change</b></td> <td><b>Back</b></td> </tr> </table>		<b>Change</b>	<b>Back</b>
<b>Change</b>	<b>Back</b>		

7. Select number of calibration points at menu item **[2] Point count**.

Calibration			
How to Calibrate			
<b>1</b>	<b>Quantity</b> RH [%RH]		
<b>2</b>	<b>Point count</b> 2		
<b>3</b>	<b>Point 1</b> —		
<b>4</b>	<b>Point 2</b> —		
<b>5</b>	<b>Note</b> **VAISA...		
<b>6</b>	<b>Apply</b>		
<table border="0"> <tr> <td><b>Change</b></td> <td><b>Back</b></td> </tr> </table>		<b>Change</b>	<b>Back</b>
<b>Change</b>	<b>Back</b>		

8. Place the probe in the first reference environment (first calibration point). Wait 20 – 40 minutes for the reading to stabilize.

- 9. Select **[3] Point 1 > Set**. The meter now shows the currently measured value of the selected parameter. Set the reference value using the arrow buttons and select **OK**.

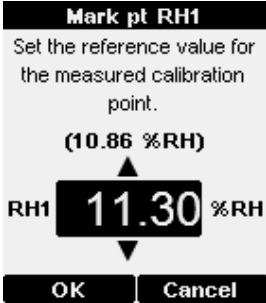

Correction to measurement at point 1 is now shown in the text for menu item **[3] Point 1**. If you are only doing a 1-point calibration, skip to [step 12](#).

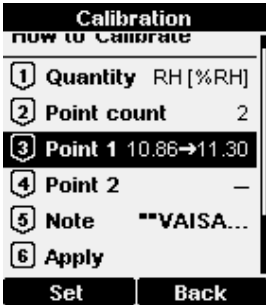

- 10. Place the probe in the second reference environment (second calibration point). Wait 20 – 40 minutes for the reading to stabilize.

11. Select **[4] Point 2 > Set** The meter now shows the currently measured value of the selected parameter. Set the reference value using the arrow buttons and select **OK**.

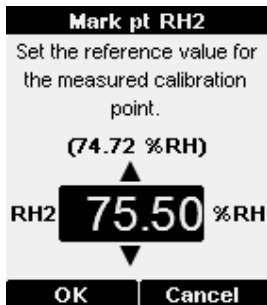

Correction to measurement at point 2 is now shown in the text for the menu item **[4] Point 2**.

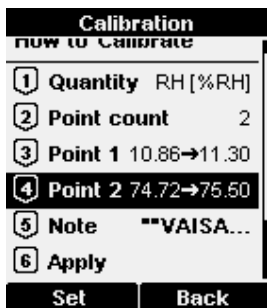

12. Select **[5] Note** to edit the calibration info text that will be stored in the probe when the adjustment is applied in [step 13](#). Edit the text using the select button and arrow keys. When done, select the **OK** character in the bottom right corner. To exit without changing the text, select **Cancel**.



13. Select **[6] Apply** to view the calibration result. Verify the corrections in the confirmation screen and select **Apply** to apply the adjustment to the probe, or **Cancel** to exit without applying the adjustment.

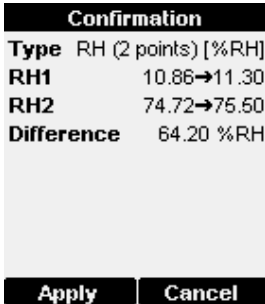

14. Disconnect the probe from the HM40.
15. Connect the probe to the data logger.

**More Information**

- [Replacing the Probe \(page 35\)](#)

## 5.4.4 Calibration and Adjustment Using MI70



- Vaisala MI70 Measurement Indicator
- Connection cable for MI70 Measurement Indicator (Vaisala item 219980SP)
- Reference environments for the desired calibration points
- RFL100 data logger with the probe to be calibrated

Optional:

- MI70-compatible reference probe and connection cable

You can calibrate and adjust the probe of your RFL100 data logger in one or two points using the MI70 indicator. For a 2-point calibration, you need two reference environments. For example, LiCl and NaCl salt chambers provide 11% and 75% relative humidity references. Note that when performing a 2-point RH calibration, the first point requires a < 50% RH humidity reference, and the second point must be > 50% RH. The difference between the two humidity references must be at least 30% RH.

Using the MI70 indicator, you can also do the 1-point calibration so that you compare the reading of the probe to any MI70-compatible Vaisala probe that provides the same measurement parameter.

- ▶ 1. Disconnect the probe from the data logger.
2. Connect the probe to be calibrated to port I of the MI70 measurement indicator using the connection cable.
3. If you want to calibrate by comparing to the reading of a reference probe, connect it to port II of the MI70 indicator.
4. Turn on the MI70 indicator.
5. Start the adjustment sequence from **Main menu > Functions > Adjustments**. If you have two probes connected, make sure to start the adjustment sequence for probe I.
6. MI70 notifies you that automatic power off is disabled during adjustment mode, select **OK** to acknowledge.
7. Select **RH** or **T** parameter for adjustment and select **OK**. This procedure assumes you are adjusting relative humidity, but the same principles apply for temperature adjustment.
8. Insert the probe to be calibrated in the reference environment. If you are calibrating relative humidity using two reference environments, use the dry reference first. If you have a reference probe, insert that in the same environment. If you are comparing against the reading of a reference probe, you can also use the ambient condition as the reference environment, as long as its conditions are stable.
9. Wait for the measurement to stabilize. You can follow the stabilization from the **GRAPH** display. Select **ADJUST** when the reading is stabilized in the reference.

10. To perform the adjustment using one reference environment (1-point adjustment), perform these steps:
  - a. Select **1-point adjustment > SELECT > OK**.
  - b. When the measurement is stable, select **READY**.
  - c. Give the reference RH value by using the arrow buttons and select **OK**.
  - d. To confirm the adjustment, select **YES**. If you select **NO**, you return to the adjustment mode display and no changes are made.
  - e. Continue from [step 13](#).
11. To perform the adjustment using two reference environments (two-point adjustment), perform these steps:
  - a. Select **2-point adjustment > SELECT > OK**.
  - b. When the measurement is stable, select **READY**.
  - c. Give the reference RH value by using the arrow buttons and select **OK**.
  - d. Insert the probe to be calibrated in the second reference environment.
  - e. When the measurement is stable, select **READY**.
  - f. Give the reference RH value by using the arrow buttons and select **OK**.
  - g. To confirm the adjustment, select **YES**. If you select **NO**, you return to the adjustment mode display and no changes are made.
  - h. Continue from [step 13](#).
12. To perform the adjustment using a reference probe, perform these steps:
  - a. Select **To same as RH[II]**.
  - b. To confirm the adjustment, select **YES**. If you select **NO**, you return to the adjustment mode display and no changes are made.
13. Calibration and adjustment is now completed. Select **BACK** to exit the adjustment mode and **EXIT** to return to the basic display.
14. Disconnect the calibrated probe from the MI70 indicator.
15. Reconnect the probe to the data logger.

#### More Information

- [Replacing the Probe \(page 35\)](#)

### 5.4.5 Adjusting Measurement Using Insight Software

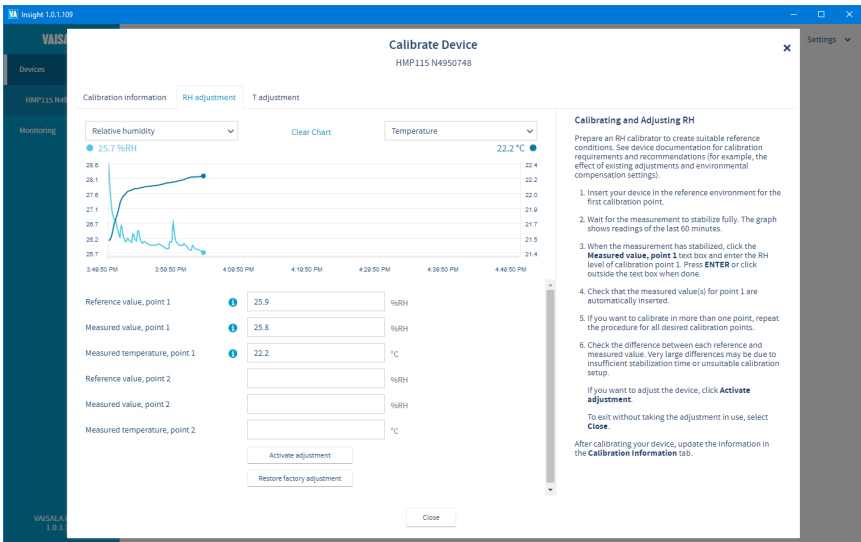



Figure 17 Adjusting Relative Humidity Measurement in Insight

-  • Computer with Windows operating system and Vaisala Insight software installed
- Vaisala USB cable 219690 for connecting the probe
- Reference environment(s) for producing the desired humidity and/or temperature

This procedure can be used to adjust the probe's humidity or temperature measurement. If you want to adjust both, adjust temperature measurement first, then repeat the procedure for humidity.

Because stabilization of temperature and humidity takes time, you should expect the adjustment procedure to take at least 30 minutes for each adjustment point.

- ▶ 1. Disconnect the probe from the data logger.
2. Connect the probe to Insight. See [Connecting Probe to Insight Software \(page 33\)](#).
3. Select  > **Calibrate** > **Yes** to switch the probe to calibration mode.  
In calibration mode, the device will not use functions that may interfere with calibration and adjustment.
4. Select the type of adjustment to perform: **RH adjustment** or **T adjustment**.



5. Define the needed adjustment for the first adjustment point:
  - a. Insert the probe head in the reference environment for the first adjustment point.
  - b. Wait for the measurement to stabilize fully.
  - c. Click the **Reference value, point 1** text box and enter the reference value of the adjustment point. Press **ENTER** or click outside the text box when done.
  - d. The probe automatically enters the measured values for the adjustment point.
6. If you want to adjust in more than one point, repeat [step 5](#) for all desired adjustment points.
7. Select **Activate adjustment > Yes** to store the adjustment in the probe.
8. Check the message that appears at the top of the screen. If the message indicates that the adjustment is activated successfully, your adjustment is stored in the probe.
9. Select the **Calibration Information** tab and update the **Calibration date** and **Calibration text**.
10. Select **Close > Yes** to exit the calibration mode.
11. Disconnect the probe from the USB cable.
12. Connect the probe to the data logger.

#### More Information

- [Vaisala Insight Software \(page 32\)](#)
- [Replacing the Probe \(page 35\)](#)

## 5.5 Changing RFL100 Batteries



- 2 pcs of new AA size 1.5 V batteries: alkaline (type LR6) or lithium (type FR6)

- ▶ 1. Remove the data logger from the mounting bracket.
2. Open the battery cover of the data logger.
3. Move the power switch to the **Off** position.
4. Remove the old AA size batteries from the data logger.
5. Check the battery orientation markings on the data logger and insert the new batteries in the correct orientation.
6. Move the power switch to the **On** position.
7. Close the battery cover of the data logger. **Push the latch down until you hear a click.** If the cover does not close easily, push the probe (or the probe cable) in and try again.
8. Insert the data logger back in the mounting bracket.

## 5.6 Changing RFL100 Clock Battery



- New 3 V lithium battery (type CR1/3N button cell)
- Small flat-head screwdriver

- ▶ 1. Open the battery cover of the data logger.
2. Use a small flat-head screwdriver to lift the top part of the small plastic cover marked **Clock battery (CR1/3N)**, and slide the cover upward until it comes loose.
3. Use the small screwdriver to lift the old clock battery from the battery socket.
4. Take the new clock battery and verify the + and - markings of the battery itself and the clock battery socket. Insert the new clock battery in the clock battery socket.
5. Replace the clock battery cover.
6. Close the battery cover of the data logger. **Push the latch down until you hear a click.** If the cover does not close easily, push the probe (or the probe cable) in and try again.

## 5.7 Updating RFL100 Firmware



Required:

- Computer with a free USB port and an operating system that supports the Media Transfer Protocol (MTP). For example, Windows® 7 and newer.
- USB connection cable (USB 2.0 Type A - Micro-B, Vaisala cable 244961). You can also use a generic cable that has all pins connected (not just power).
- RFL100 firmware update file from Vaisala



**CAUTION!** Updating RFL100 firmware erases the recorded data on the device. Before updating, verify from the viewLinc Enterprise Server that up-to-date data from this device is available. You can also copy the data from the device; see [Downloading Data Using Service Port \(page 52\)](#).

Updating the firmware will not affect the data logger's status in the Vaisala viewLinc Monitoring System. If the device was accepted in the system before the update, it will remain accepted.

- ▶ 1. Before starting the firmware update, read the release notes that are included with the file. The release notes contain a summary of important changes and possible compatibility requirements.
2. Turn the RFL100 on. The currently installed firmware version is shown briefly during start-up. If the firmware version you have downloaded is newer than the installed version, continue with the update.

3. Open the plug that covers the service port and connect the USB cable between your computer and the service port of the RFL100. After the computer detects the RFL100 and installs the appropriate driver, it is available for file transfer.
4. Copy the firmware update file supplied by Vaisala into the `\Data\Update` folder on the RFL100. Select to overwrite the old file when prompted by your computer. If the file is valid, RFL100 begins the update automatically. Do not unplug the cable or turn off the RFL100 during the update.
5. Monitor the update progress on the display of the RFL100. When the update is done, you will see **UPD OK** message on the display.
6. Disconnect the USB cable and close the plug over the service port.

## 6. Troubleshooting

### 6.1 Problem Situations

Table 10 Troubleshooting Table

Problem	Possible Cause	Solution
Display shows one or more error codes.	Various causes.	Check meaning of the error code(s) and proceed accordingly. See <a href="#">Error Codes (page 51)</a> .
You are adding a new RFL100 Data Logger to the system but it is not coming up as a <b>New Device</b> in viewLinc.	RFL100 is not in range of an AP10 that has <b>installation mode</b> turned on, and capacity to add more data loggers (maximum 32 for each AP10).	Turn on installation mode in an AP10 that is within 100 m of the data logger, and has capacity to add more data loggers.
	RFL100 is connected to an AP10 that is not connected to viewLinc.	Verify the following: <ul style="list-style-type: none"> <li>• AP10 is connected to the network and has an IP address.</li> <li>• AP10 is configured to connect to the correct viewLinc Enterprise Server.</li> <li>• viewLinc connection of the AP10 is OK.</li> </ul>
	RFL100 has been previously accepted to a different viewLinc system.	Press the <b>Release</b> button of the RFL100 and verify that the message <b>NWK REL</b> appears on screen. The RFL100 is now ready to join any AP10 that is in installation mode.
	RFL100 has joined an AP10 but has not been accepted to the viewLinc system. The AP10 is no longer in range, but RFL100 cannot change to a different access point as it is pending to be accepted to the system.	

Problem	Possible Cause	Solution
RFL100 turns off by itself.	Display and LED of the RFL100 have been turned off remotely using viewLinc Enterprise Server. All other functions of the data logger remain active.	You can change the setting from the <b>Hosts and Devices</b> tree in viewLinc Enterprise Server.  If you are connecting the RFL100 to a new viewLinc Monitoring System and you want the display and LED back on again, press the <b>Release</b> button of the RFL100 and verify that the message <b>NWK REL</b> appears on screen.
	Main batteries are empty.	Replace the main batteries. See <a href="#">Changing RFL100 Batteries (page 47)</a> .

## 6.2 Error Codes

Table 11 RFL100 Error Codes

Error Code	Cause	Recommended Action
Err 100	User parameter bank checksum failure.	Turn the data logger off and on again. If the error persists, contact Vaisala.
Err 101	Factory parameter bank checksum failure.	Turn the data logger off and on again. If the error persists, contact Vaisala.
Err 102	Real-time clock of the data logger has lost accurate time.	Restore the wireless connection to an AP10 access point. RFL100 will synchronize its clock with the time from the access point.
Err 103	Main battery voltage is critically low. Data logger has stopped radio communication to conserve energy but continues to record measurement data in the local memory.	Replace main batteries. See <a href="#">Changing RFL100 Batteries (page 47)</a> .
Err 104	Incorrect factory configuration parameters.	Turn the data logger off and on again. If the error persists, contact Vaisala.
Err 105	Real-time clock hardware error.	Turn the data logger off and on again. If the error persists, contact Vaisala.
Err 200	Real-time clock battery voltage is low.	Replace the clock battery. See <a href="#">Changing RFL100 Clock Battery (page 48)</a> .

Error Code	Cause	Recommended Action
Err 202	Probe communication failure.	Check that the probe is connected properly.
Err 203	Probe error. Can be caused by probe incompatibility, damage, or a wet humidity sensor.	Inspect the probe and replace it if necessary. If the error has been caused by a wet humidity sensor, wait for it to dry out.
Err 204	Real-time clock temperature compensation problem.	<ol style="list-style-type: none"> <li>1. If error code <b>Err 200</b> is also active, replace the clock battery. See <a href="#">Changing RFL100 Clock Battery (page 48)</a>.</li> <li>2. Turn the data logger off and on again.</li> <li>3. If the error persists, contact Vaisala.</li> </ol>

### 6.3 Verifying Operation of RFL100

- ▶ 1. Open the battery cover of the data logger.
- 2. Move the power switch to the **On** position.
- 3. Look at the display and verify that:
  - Battery indicator shows full batteries .
  - Display shows measurement readings instead of dashes or error codes.

If measurement readings are not shown after a few seconds, check that the probe is properly connected. It is possible to disconnect the probe by pulling on the probe with the battery cover open. In that case the display will show error code **Err 202**.
- 4. Move the power switch to the **Off** position.
- 5. Close the battery cover of the data logger. **Push the latch down until you hear a click.** If the cover does not close easily, push the probe (or the probe cable) in and try again.

### 6.4 Downloading Data Using Service Port



- Computer with a free USB port and an operating system that supports the Media Transfer Protocol (MTP). For example, Windows® 7 and newer.
- USB connection cable (USB 2.0 Type A - Micro-B, Vaisala cable 244961). You can also use a generic cable that has all pins connected (not just power).

- ▶ 1. Open the plug that covers the service port.
- 2. Connect the USB cable between your computer and the service port of the RFL100 Data Logger. When the computer detects the RFL100, it is available for file transfer.
- 3. Navigate to the `\Data\Log` folder on the RFL100.

- Copy the following files from the folder to retrieve the data:

Filename	Content
Log_1h.txt	Measurement data from the past hour.
Log_24h.txt	Measurement data from the past 24 hours.
Log_30d.txt	Measurement data from the past 30 days.

- Disconnect the USB cable and close the plug over the service port.

## 6.5 Performing a Factory Reset



- Pen or a small flat head screwdriver

Factory reset provides a way to attempt recovery from serious operating errors that prevent normal startup or operation. It is not needed as part of normal use of RFL100, and should only be done in cases where it is advised by troubleshooting instructions or Vaisala Support.

Factory reset clears all user settings on the RFL100 much in the same way as pressing the **Release** button. Additionally, factory reset restores some lower level settings that are not user changeable. Factory reset will not clear existing data on the data logger.

- Open the battery cover of the data logger.
- Move the power switch to the **Off** position.
- Hold down the **Release** button using a pen or a small flat-head screwdriver, and move the power switch to the **On** position. Keep holding down the **Release** button during start-up until you see the text **FCT RST** on the display. If you do not see the text appear, turn the data logger off and try again.
- After a successful factory reset, the data logger will continue operating normally. To make sure factory settings are in use, move the power switch to the **Off** position, wait for a few seconds, and turn it back to **On** position. Verify from the display that the data logger starts up normally.
- Close the battery cover of the data logger. **Push the latch down until you hear a click.** If the cover does not close easily, push the probe (or the probe cable) in and try again.

After the factory reset, RFL100 will be ready to join any compatible viewLinc Monitoring System after a delay of 4 ... 6 minutes. The connecting access point must be in installation mode.

## 7. Technical Data

### 7.1 RFL100 Technical Specification

Table 12 Wireless

Property	Specification
Networking standards	Vaisala VaiNet
Modulation	LoRa™ chirp spread spectrum modulation
Output power	14 dBm (25 mW)
Antenna	Internal
Typical range (indoors)	At least 100 m (328 ft)
Range with line-of-sight	Over 500 m (1640 ft)
Frequency bands	868 MHz (Europe) 915 MHz (North America, Australia, and New Zealand)
<b>Safety</b>	
Electrical safety	EN/UL/IEC 61010-1
RF exposure	KDB 447498 (United States) RSS-102 Issue 5 (Canada)
<b>EMC and Radio Standards</b>	
EMC compliance	EN/IEC 61326-1, industrial environment
868 MHz model	ETSI EN 300 220-2 EN 301 489-1 EN 301 489-3
915 MHz model	FCC title 47 part 15.247 (FCC ID: 2AO39-RFL100A) ICE RSS-247 (IC: 23830-RFL100A) AS/NZS 4268

Table 13 Memory

Property	Specification
Sample capacity	30 days (43200 samples per channel)
Memory type	Non-volatile EEPROM



Property	Specification
Memory mode	Ring buffer (FIFO)
Sampling rate	One sample / channel / minute (non-changeable)

Table 14 Operating Environment

Property	Description/Value
Storage temperature	-40 ... +60 °C (-40 ... +140 °F)
Operating humidity	0 ... 100 %RH, non-condensing
<b>Operating Temperature</b> <sup>1)</sup>	
with alkaline batteries	+2 ... +60 °C (+35.6 ... +140 °F)
with lithium batteries	-20 ... +60 °C (-4 ... +140 °F)

1) For both alkaline and lithium, battery temperature operating specifications apply.

Table 15 General

Property	Specification
Compatible probes	HMP115, HMP115T HMP110, HMP110T (cabled only) TMP115
Compatible viewLinc versions	5.0 and above
Batteries	2 × AA sized, 1.5 V (LR6 or FR6)
Clock battery	CR 1/3N (3 V lithium button cell)
Operation time at 20 °C (without external power supply)	18 months
Internal clock accuracy	±30 s/month Synchronizes with Network Time Protocol (NTP) server

Table 16 Mechanical Specifications

Property	Specification
Housing color	White
Mounting methods	Screws, tie-wrap, hook, or magnetic mounting bracket (optional accessory)
Probe interface	4-pin female M8 connector

Property	Specification
Service port	USB 2.0 with Micro-USB connector
IP rating	IP54
<b>Dimensions (H × W × D) with HMP115 Probe</b>	
Without mounting bracket	158 × 62 × 31 mm (6.22 × 2.4 × 1.22 in)
With mounting bracket	186 × 68 × 36.5 mm (7.32 × 2.68 × 1.44 in)
<b>Weight</b>	
With batteries (2 pcs alkaline) and HMP115 probe	190 g (6.7 oz)
With batteries (2 pcs alkaline), HMP115 probe, and magnetic mounting bracket	254 g (8.96 oz)
<b>Materials</b>	
Housing	PC/ABS blend
Display window	PMMA (acrylic)
Sealings	TPE

## 7.2 RFL100 Compatible Probes Technical Specification

Table 17 HMP110/T Probe Measurement Performance

Property	Description/Value
<b>Relative Humidity</b>	
Measurement range	0 ... 100 %RH
<b>Accuracy in Temperature Range 0 ... +40 °C (+32 ... +104 °F) <sup>1)</sup></b>	
0 ... 90 %RH	±1.5 %RH
90 ... 100 %RH	±2.5 %RH
<b>Accuracy in Temperature Range -40 ... 0 °C, +40 ... +80 °C (-40 ... +32 °F, +104 ... +176 °F) <sup>1)</sup></b>	
0 ... 90 %RH	±3.0 %RH
90 ... 100 %RH	±4.0 %RH
<b>Factory Calibration Uncertainty at +20 °C (68 °F) <sup>2)</sup></b>	
0 ... 90 %RH	±1.1 %RH
90 ... 100 %RH	±1.8 %RH
Humidity sensor	Vaisala HUMICAP® 180R

Property	Description/Value
Stability	±2 %RH over 2 years
<b>Temperature</b>	
Measurement range	-40 ... +80 °C (-40 °F ... +176 °F)
<b>Accuracy over Temperature Range</b>	
at 0 ... +40 °C (+32 °F ... +104 °F)	± 0.2 °C (0.36 °F)
at -40 ... 0 °C, +40 ... +80 °C (-40 ... +32 °F, +104 ... +176 °F)	± 0.4 °C (0.72 °F)
Factory calibration uncertainty <sup>2)</sup>	± 0.2 °C (0.36 °F)
Temperature sensor	Pt1000 RTD Class F0.1 IEC 60751

1) Includes non-linearity, hysteresis, and repeatability.

2) Small variations possible; see also calibration certificate.

Table 18 HMP115/T Probe Measurement Performance

Property	Description/Value
<b>Relative Humidity</b>	
Measurement range	0 ... 100 %RH
<b>Accuracy in Temperature Range 0 ... +40 °C (+32 ... +104 °F) <sup>1)</sup></b>	
0 ... 90 %RH	±1.5 %RH
90 ... 100 %RH	±2.5 %RH
<b>Accuracy in Temperature Range -40 ... 0 °C, +40 ... +60 °C (-40 ... +32 °F, +104 ... +140 °F) <sup>1)</sup></b>	
0 ... 90 %RH	±3.0 %RH
90 ... 100 %RH	±4.0 %RH
<b>Factory Calibration Uncertainty at +20 °C (68 °F) <sup>2)</sup></b>	
0 ... 40 %RH	±0.6 %RH
40 ... 75 %RH	±1.0 %RH
Humidity sensor	Vaisala HUMICAP® 180R
Stability	±2 %RH over 2 years
<b>Temperature</b>	
Measurement range	-40 ... +60 °C (-40 °F ... +140 °F)
<b>Accuracy over Temperature Range</b>	

Property	Description/Value
at 0 ... +40 °C (+32 ... +104 °F)	± 0.2 °C (0.36 °F)
at -40 ... 0 °C, +40 ... +60 °C (-40 ... +32 °F, +104 ... +140 °F)	± 0.4 °C (0.72 °F)
Factory calibration uncertainty <sup>2)</sup>	± 0.1 °C (0.18 °F)
Temperature sensor	Pt1000 RTD Class F0.1 IEC 60751

1) Includes non-linearity, hysteresis, and repeatability.

2) Small variations possible; see also calibration certificate.

Table 19 TMP115 Probe Measurement Performance

Property	Description/Value
<b>Temperature</b>	
Measurement range	-196 ... +90 °C (-320.8 ... +194 °F)
<b>Accuracy over Temperature Range <sup>1)</sup></b>	
at -196 ... -90 °C (-320.8 ... -130 °F)	± 2.5 °C (4.5 °F)
at -90 ... -30 °C (-130 ... -22 °F)	± 0.75 °C (1.35 °F)
at -30 ... 0 °C (-22 ... +32 °F)	± 0.5 °C (0.9 °F)
at 0 ... +50 °C (+32 ... +122 °F)	± 0.25 °C (0.45 °F)
at +50 ... +90 °C (+122 ... +194 °F)	± 0.75 °C (1.35 °F)
Factory calibration uncertainty <sup>2)</sup>	± 0.08 °C (0.128 °F)
Temperature sensor	Pt100 RTD Class A IEC 751

1) Includes non-linearity, hysteresis, and repeatability.

2) Small variations possible; see also calibration certificate.

Table 20 HMP110 Probe Mechanical Specifications

Property	Specification
IP rating	IP65
Body thread	M12x1 / 10 mm (0.4 in)
Diameter	12 mm (0.47 in)
Length	78 mm (3.07 in)
<b>Materials</b>	
Probe body	Stainless steel (AISI 316)
Grid filter	Chrome coated ABS plastic

Table 21 HMP115/T Probe Mechanical Specifications

Property	Specification
IP rating	IP54
Diameter	14 mm (0.55 in)
Length	79 mm (3.11 in)
<b>Materials</b>	
Probe body	PC/ABS blend
Grid filter	PC (glass reinforced)
Sleeve	PC/ABS blend

Table 22 TMP115 Probe Mechanical Specifications

Property	Specification
IP rating	IP67 for sensor tip IP65 for probe body
<b>Materials</b>	
Probe body	PC/ABS blend
Cable	FEP
Sensor tip	Stainless steel (AISI 316)
<b>Dimensions</b>	
Probe length including cable and sensor tip	0.5 m (1 ft 7.7 in) or 3 m (9 ft 10.1 in)
Probe body diameter	14 mm (0.55 in)
Sensor tip length	50.8 mm (2 in)
Sensor tip diameter	4.76 mm (0.19 in)

## 7.3 Spare Parts and Accessories

Table 23 RFL100 Spare Parts and Accessories

Description	Vaisala Item Code
Mounting bracket (5 pcs)	DRW244769SP
Magnetic mounting bracket (5 pcs)	ASM211527SP
Battery cover (5 pcs)	DRW244766SP
Mounting kit	245679SP

Description	Vaisala Item Code
<b>Cables</b>	
Probe cable for RFL100, 3 m	CBL210555-3MSP
Probe cable for RFL100, 10 m	CBL210555-10MSP
Flat cable for RFL100, 3 m	CBL210647SP
<b>Probes</b>	
HMP110 probe	HMP110 order form, code: Z00B0C1A0
HMP110T probe	HMP110 order form, code: Z0B01A0
HMP115 probe	HMP115 order form
HMP115T probe	HMP115T order form
TMP115 probe	TMP115 order form

Table 24 HMP110/T Probe Spare Parts and Accessories

Description	Vaisala Item Code
Plastic grid filter	DRW010522SP
Plastic grid with membrane filter	DRW010525SP
Sintered stainless steel filter	HM46670SP
PTFE filter	DRW244938SP
Mounting nuts (2 pcs), hex M12 × 1 Pa 6.6	18350SP
Probe mounting clamps, heavy duty (10 pcs)	226067
Duct installation kit	215619

Table 25 HMP115/T Probe Spare Parts and Accessories

Description	Vaisala Item Code
Plastic grid filter	DRW240185SP
Plastic grid with membrane filter	ASM210856SP
PTFE filter	219452SP

Table 26 TMP115 Probe Spare Parts and Accessories

Description	Vaisala Item Code
Thermal dampener block for 3/16" probes (4.8 mm)	236310SP

## 7.4 Dimension Drawings

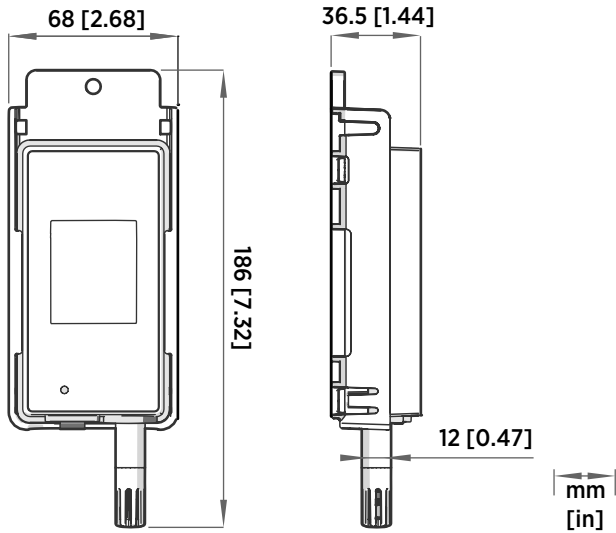

Figure 18 RFL100 Dimensions with Mounting Bracket

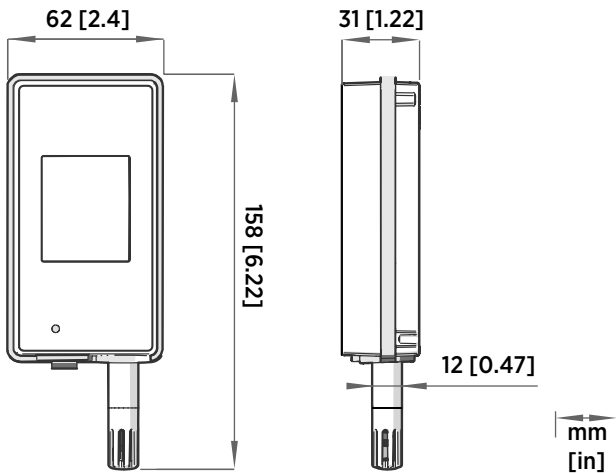

Figure 19 RFL100 Dimensions without Mounting Bracket

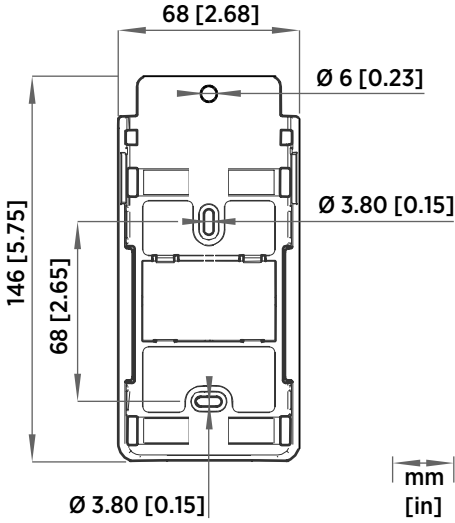

Figure 20 RFL100 Mounting Bracket Dimensions

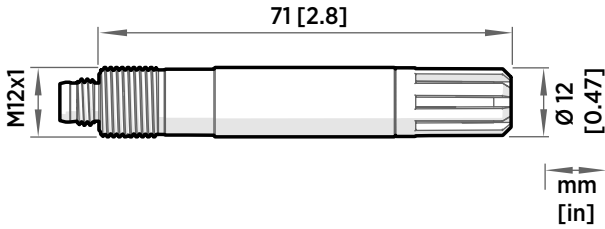

Figure 21 HMP110 Probe Dimensions

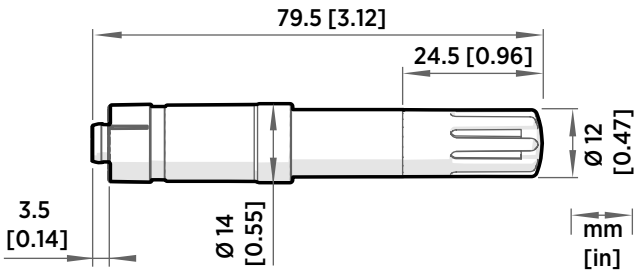

Figure 22 HMP115 Probe Dimensions



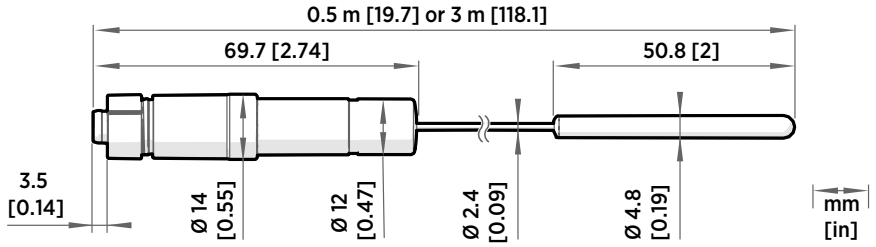

Figure 23 TMP115 Probe Dimensions



## Technical Support



Contact Vaisala technical support at [helpdesk@vaisala.com](mailto:helpdesk@vaisala.com). Provide at least the following supporting information:

- Product name, model, and serial number
- Name and location of the installation site
- Name and contact information of a technical person who can provide further information on the problem

For more information, see [www.vaisala.com/support](http://www.vaisala.com/support).

## Warranty

For standard warranty terms and conditions, see [www.vaisala.com/warranty](http://www.vaisala.com/warranty).

Please observe that any such warranty may not be valid in case of damage due to normal wear and tear, exceptional operating conditions, negligent handling or installation, or unauthorized modifications. Please see the applicable supply contract or Conditions of Sale for details of the warranty for each product.

## Recycling

When preparing to recycle the data logger, open the battery cover and remove the main batteries and the clock battery.



Recycle all applicable material.



Follow the statutory regulations for disposing of the product, batteries, and packaging.





# VAISALA



Distributed by:

Kenelec Scientific Pty Ltd  
1300 73 22 33  
sales@kenelec.com.au  
www.kenelec.com.au

[www.vaisala.com](http://www.vaisala.com)

