

Die deutschsprachige Version kann von www.vaisala.com/PDT101 heruntergeladen werden.

Vous pouvez télécharger la version française sur www.vaisala.com/PDT101.

日本語版は www.vaisala.com/PDT101 からダウンロードできます。

您可以访问 www.vaisala.com/PDT101 下载简体中文翻译。

WARNING - READ BEFORE INSTALLATION

Vaisala Differential Pressure Transmitter PDT101 is a high-performance instrument designed primarily for use in life science and cleanroom applications. PDT101 is not authorized for use as a critical component in life support devices or systems. Consult Vaisala before installing if there are any questions or concerns.

Overpressure: Pressure spikes in excess of the rated overpressure capability of the transmitter may cause irreversible electrical and/or mechanical damage to the transmitter.

Static electrical charges: To avoid damage to the transmitter the operator/installer should follow proper ESD (electrostatic discharge) protection procedures.

TECHNICAL SPECIFICATION

Performance

Measurement range (bidirectional)		±60 Pa or ±0.25 in H ₂ O
Overpressure	Proof pressure	1.0 bar
	Burst pressure	1.7 bar
	Static pressure	1.7 bar
Pressure type		Differential, gauge, vacuum and compound
Accuracy	(incl. non-linearity, hysteresis, repeatability and zero/span calibration settings)	0.4 % span
Long-term stability		≤0.5 % span/year
Response time (10...90 %)		250 ms
Warm-up time		15 s
Compensated temperature range		+2...+54 °C (+35.6...+129.2 °F)
Temperature dependence		±(0.065 Pa + 0.054 % of reading) / °C or ±(0.00015 inH ₂ O + 0.03 % of reading) / °F (reference 21 °C or 70 °F)
Mounting position error (zero adjustable)		≤1 %/g (calibration in vertical position is standard)
Adjustments (front accessible)	Zero (span low)	±5 % span
	Span (span high)	±3 % span

Operating environment

Operating temperature	-18...+70 °C (-0.4...+158 °F)
Storage temperature	-40...+82 °C (-40...+179.6 °F)
Electromagnetic compatibility	EN61326-1, Basic immunity test requirements

Note: If used in an electromagnetic field of 3 V/m, with narrow frequency area of 80 - 120 MHz, it is possible that the current output of PDT101 can deviate max. 0.8% (with accuracy specified 0.4%).

Inputs and outputs

Process connection		1/4" barbed fittings
Output signal	2-wire	4...20 mA
	3-wire	0...5 VDC (user selectable 0...10 VDC)
Operating voltage	2-wire output 4...20 mA	12...36 VDC
	3-wire output 0...5 VDC	11.5...36 VDC
	3-wire output 0...10 VDC	14...36 VDC or 24 VAC

Max. loop resistance for 4...20 mA	≤ (Supply voltage - 12V)/0.022 A
Supply current	max. 20 mA for 4...20 mA output signal
Optical process diagnostics	LED visual indicator
Electrical connection	Euro style pluggable terminal block accepts 12...26 AWG wire (0.13 up to 3.31 mm ²)

Mechanics

Medium (measured gas)	Clean and dry air, non-conducting and non-corrosive gases
Material	Brass
Process connection	
Sensor element	Silicon, aluminum, glass
Case	NEMA type 1 fire-retardant ABS 1 (meets UL94-5VA)
Mounting	Threaded fastener for wall mounting or DIN rail type EN50022
Housing classification	IP40
Weight	0.07 kg

MOUNTING

The transmitter can be mounted on an EN550022 rail or with M4 (#8) or M5 (#10) screws using the mounting holes provided.

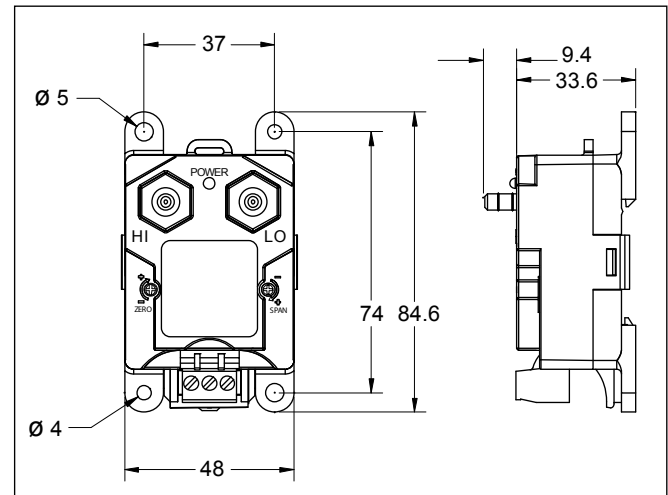

Figure 1 Dimensions (in mm)

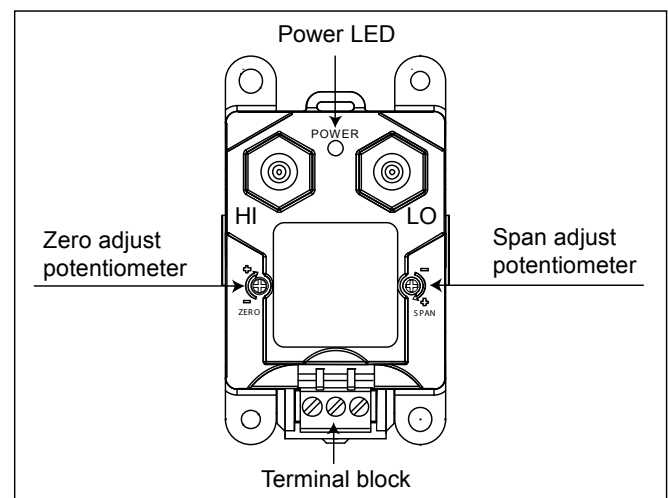

Figure 2 PDT101 Transmitter

SETUP

Transmitters are calibrated in a vertical position at the factory. Mounting in a horizontal position may cause a zero shift of as much as +/- 1 % of span. To check for zero shift, see section Calibration below.

ELECTRICAL WIRING

1. Remove the terminal block from the front of the transmitter.
2. Follow the terminal block label markings on the PDT101 to identify the terminals, and connect the wires.
3. Firmly reinstall the terminal block plug to its mating connector.

Current Output Wiring (Black Terminal Block)

The left, negative (-), and right, positive (+) terminals are used, ignore the center terminal which is not used. Connect the power supply positive lead to the PDT101 positive terminal, connect the negative power supply lead to the negative terminal of the BCS 4...20 mA input. Last, connect the (-) negative terminal on the PDT101 to the (+) positive BCS input.

Use of a shielded cable, with the shield grounded, is required. Do not connect the shield to the transmitter.

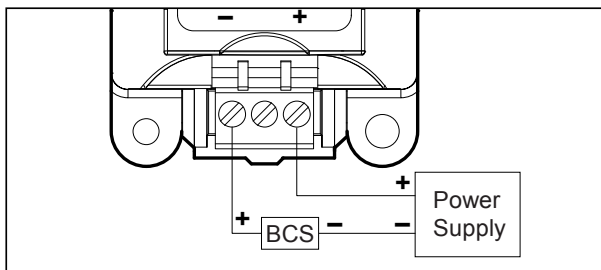

Figure 3 Current Output Wiring

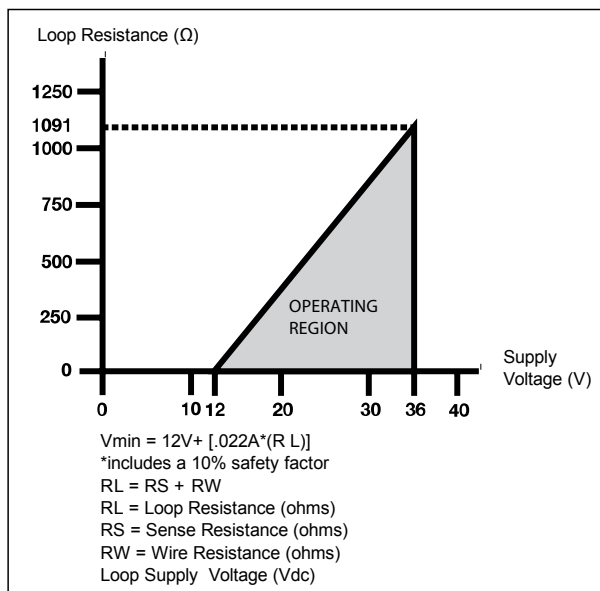

Figure 4 Load Limitations

Voltage Output Wiring (Green Terminal Block)

The left terminal is the common (supply and output negative), the right terminal is the V_{in} (supply positive). The middle terminal is the V_{out} (output signal).

Use of a shielded cable, with the shield grounded, is required. Do not connect the shield to the transmitter. Maximum cable length for voltage output wiring is 30 m (98.4 ft).

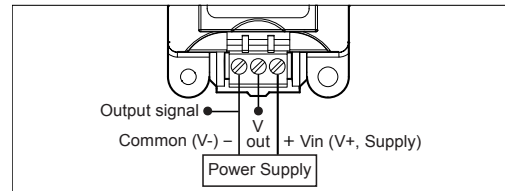

Figure 5 Voltage Output Wiring

The PDT101 voltage output model is supplied as standard with 0...5 VDC output. You can convert the unit to 0...10 VDC output by moving a jumper inside the transmitter. Access the jumper by simultaneously pushing both housing tabs away from the housing. Change jumper (orange) to the left as shown below, and carefully reattach the housing cover. When finished, mark the checkbox on front label indicating that the unit now provides a 0...10 VDC output.

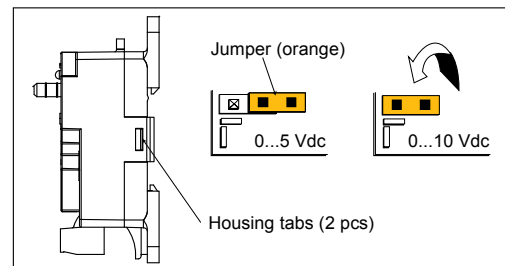

Figure 6 Voltage Output Jumper

CALIBRATION

1. Pneumatically connect the transmitter's pressure ports to each other. The barbed pressure connections accept 1/4" O.D. 1/8" I.D. tubing.
2. Measure the analog output of the transmitter to establish the zero offset reading in the as-installed position.
3. If the reading is not at the middle of the output range (for example, 12 mA for 4 ... 20 mA output), the zero point of the transmitter has shifted. To remove the zero shift, adjust the transmitter as described below.

ADJUSTMENT

Note: You need a high accuracy pressure standard and high quality electrical meter to adjust the PDT101.

1. Connect the pressure standard to the ports of the PDT101.
2. Bring the pressure to 0 % of the transmitter's span (-60 Pa or -0.25 in H₂O, depending on model).
3. Adjust the zero potentiometer (on the front, left side of the transmitter) so that the analog output value is at the low end of its range. Use a 3/32" or 2.5 mm slotted or Phillips screwdriver to turn the potentiometer.
4. Now bring the pressure to 100 % of the transmitter's span (+60 Pa or +0.25 in H₂O, depending on model).
5. Adjust the span potentiometer (on the front, right side of the transmitter) so that the analog output value is at the high end of its range.

REMOVAL FROM DIN RAIL

1. Unplug the wiring terminal block from the transmitter.
2. Insert a small slotted screwdriver into the black plastic clip extending slightly below the transmitter case.
3. Raise the screwdriver handle up thereby forcing the spring clip down.

WARRANTY

For warranty information, visit our Internet pages at: www.vaisala.com/warranty.

DISPOSAL

Dispose of the unit according to local regulations. Do not dispose of with regular household waste. Recycle all applicable material.