

ALARM OUTPUT FOR THE TSI[®] DUSTTRAK[™] AEROSOL MONITOR MODEL 8520

APPLICATION NOTE ITI-074

Introduction

Newer models of the DUSTTRAK[™] Model 8520 have an alarm output feature. A switch closure that is tied to the alarm output value (setpoint) is user-selectable via TRAKPRO[™] Data Analysis Software. The DUSTTRAK[™] aerosol monitor is capable of activating an external alarm when the measured mass concentration reaches or exceeds the alarm setpoint value. A deadband of -5% of the alarm setpoint and a minimum switch closure time of 5 seconds prevent nuisance alarms. There is also an audio-visual alarm indication on the DUSTTRAK[™] monitor.

How to tell if your DUSTTRAK[™] Aerosol Monitor has Analog/Alarm Output Capability

All DUSTTRAK[™] monitors have the analog output and alarm functions as of **10/18/00** beginning with serial number **22499**. You can visually verify if your DUSTTRAK[™] monitor is equipped with these features. Look for the 4-pin, mini-DIN connector labeled "Analog/Alarm Output". It is located on the backside of the instrument (a picture of this connector and label is shown below). All DUSTTRAK[™] monitors with serial numbers from **21960** to **22498** can be upgraded to incorporate these functions for a nominal fee. Older DUSTTRAK[™] monitors with serial numbers lower than **21960** **cannot** be upgraded to incorporate this new feature.



Note: For technical information on using the DUSTTRAK[™] monitor's analog output features see [Application Note ITI-073, Analog Output](#) on the TSI Website at www.tsi.com.

For technical information on communicating with the DUSTTRAK[™] monitor via the RS-232 serial port see [Application Note ITI-044 Serial Data Acquisition](#) on the TSI Website at www.tsi.com.

Applications

There are many potential applications for the DUSTTRAK™ alarm output. Some potential applications include:

- Environmental site perimeter monitoring for fugitive dust emission. When the alarm value set point is exceeded, the DUSTTRAK™ monitor can trigger a remote alarm system. This, in turn, could determine the need for or the use of engineering controls (such as dust control/suppression) or additional air monitoring.
- Ambient or other remote monitoring applications.
- Ambient and process area monitoring—where continuous monitoring is used to assist in evaluating process area conditions.

WARNING

The DUSTTRAK™ monitor Alarm Output function should not be used to detect hazardous conditions or to provide an alarm for protecting human life, health, or safety.

Note: *The user is responsible for determining the suitability of the DUSTTRAK™ monitor for any alarm application, and for properly implementing and integrating such a system.*

Specifications

The alarm output is a non-latching, MOSFET solid-state (polarized) analog switch. It has a setpoint range of 0.010 to 100 mg/m³. The maximum electrical ratings are 15 VDC and 1 Amp. A deadband of -5% of the alarm setpoint and a minimum switch closure time of 5 seconds prevent nuisance alarms. A 4-pin, mini-DIN connector is used for the alarm output. TSI supplies a 4-pin, mini-DIN output connector. For additional information on connecting and wiring the alarm output, see the following sections.

Switch Closure and Deadband

The DUSTTRAK™ monitor range is 0.001 to 100 mg/m³ with a resolution of 1 µg/m³. The alarm set point range is 0.010 to 100 mg/m³. The DUSTTRAK™ monitor comes pre-programmed from the factory for an alarm setpoint of 0.010 mg/m³.

When an alarm setpoint has been programmed via TRAKPRO™ software and the mass concentration reading reaches this alarm setpoint, the switch will close and remain closed for a minimum of 5 seconds. After 5 seconds have elapsed, the switch will open only if the mass concentration reading falls below the setpoint deadband. This avoids short cycling or nuisance alarms.

The deadband is -5% of the alarm set point. The switch will open only when the mass concentration reading drops 5% below the alarm set point. Examples are shown below.

Examples: Deadband

Set point (switch close)	-5% of set point	Switch Open
0.010 mg/m ³	0.0005 mg/m ³	0.009 mg/m ³
0.100 mg/m ³	0.005 mg/m ³	0.095 mg/m ³
1.000 mg/m ³	0.050 mg/m ³	0.950 mg/m ³

Analog/Alarm Output Connector

The Model 8520 DUSTTRAK™ Aerosol Monitor contains a connector that serves both the analog and alarm output functions. The DUSTTRAK™ monitor is supplied with an output cable. The cable contains a 4-pin, mini-DIN connector. The pin-outs for the connector and the wiring for the cable are shown below.

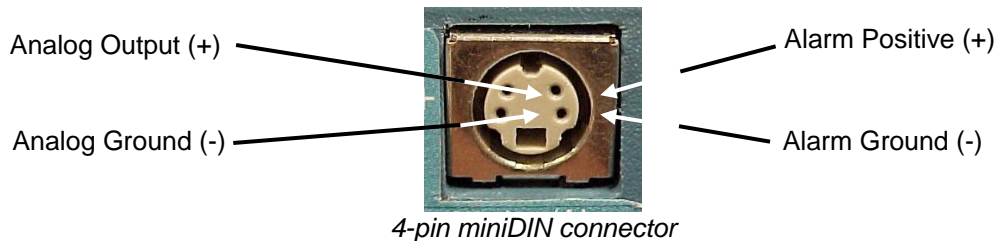

Cable Wiring Diagram	
Brown Wire	Analog Gnd
Orange Wire	Analog Out
Red Wire	Alarm (+)
White Wire	Alarm (-)
Black Wire	Shield

Wiring the Alarm

The user is responsible for designing and selecting the actual alarm system to be used with the DUSTTRAK monitor and for implementing and integrating the designed system. Please note the following important specifications for that system:

- Maximum voltage: 15 VDC (**DO NOT USE AC POWER**)
- Maximum current: 1 Amp
- Correct polarity must be observed (see pin-outs above)
- The alarm switch, located inside the DUSTTRAK™ monitor, must be located on the ground side of the alarm system. See wiring example, below.

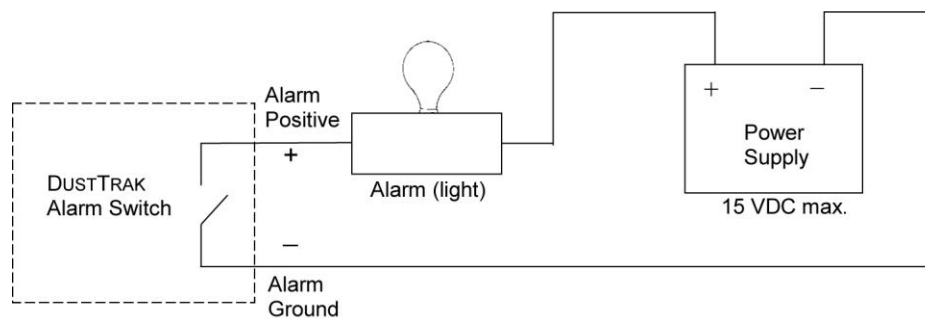

Since applications of this function will vary, TSI supplies only the output cable (part no. 801652). The output cable is labeled with the pin-out wiring diagram. The user is responsible for all additional equipment needed for making connections to their own equipment.



Troubleshooting

The table below lists the symptoms, possible causes, and recommended corrective actions for common problems encountered with the DUSTTRAK alarm output.

Symptom	Possible Cause	Corrective Action
Alarm output does not work.	Alarm function not turned on.	Alarm function is “off” by default. It must be programmed “on” (using TRAKPRO software).
Alarm does not turn on correctly.	Alarm setting incorrect.	Program alarm setting using TRAKPRO software.
	Cable/connector not correctly installed.	Make sure cable connector is fully seated.
	Alarm output wired with reverse polarity.	Alarm contacts are polarized. Voltage input must be wired to alarm input (+).

Programming the Alarm Function using TRAKPRO Software

The DUSTTRAK™ monitor is shipped from the factory with the alarm setpoint at 0.100 mg/m³ and with the alarm function disabled. In order for the alarm switch to work, the user must enable the alarm function using TRAKPRO™ software.

Programming the Alarm Setpoint

To program the alarm output function, do the following:

1. Connect the DUSTTRAK™ monitor to the computer with the RS-232 serial cable. Install the RJ-45 connector into the DUSTTRAK™ monitor connector port and the serial cable into the serial port on your computer.
2. Turn on the DUSTTRAK™ monitor and start the TRAKPRO™ software (version 3.1 or higher).
3. Select **Parameters**, **Alarm Set point**, from the **Instrument Setup** menu. The following dialog is displayed:

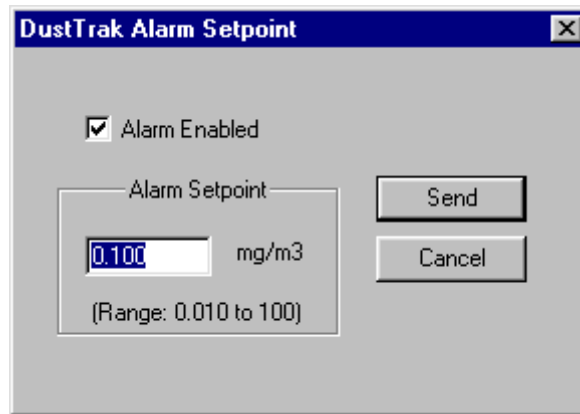

4. Turn “On” the alarm function by checking the “Alarm Enabled” check box. Enter a value within the acceptable range. In this example, the DUSTTRAK™ monitor is programmed to a setting of “0.100 mg/m³.” Press the **Send** button, to program the instrument.

Please note the following information about programming the alarm setpoint:

- The default status for the alarm feature is “Off”.
- The user may enter an alarm set point within the range from 0.010 to 100 mg/m³.
- The alarm set point and the analog output functions have no relationship one to another. For example, the user may select an analog output range at 0-1.0 mg/m³, but have the alarm set point at 10.0 mg/m³ (see [Application Note ITI-073](#), for complete information on the Analog Output function).
- The DUSTTRAK™ monitor is programmed at the factory for a default alarm set point of 0.100 mg/m³.

DUSTTRAK Audio-Visual Alarm Indication

When the DUSTTRAK™ monitor goes into an alarm condition, several things happen at the instrument:

- The DUSTTRAK™ monitor will display the letters, “AL” (abbreviation for “alarm”), indicating an alarm condition. This will flash alternately with the measured concentration approximately once per second.
- At the same time, the DUSTTRAK™ monitor internal buzzer will beep once per second and cannot be turned off or muted.
- When the measured mass concentration falls below the –5% deadband threshold, the message and beeping will stop.

To get the most current version of this document,
visit the TSI Website at www.tsi.com



UNDERSTANDING, ACCELERATED

TSI Incorporated – Visit our website www.tsi.com for more information.

USA Tel: +1 800 874 2811
UK Tel: +44 149 4 459200
France Tel: +33 4 91 11 87 64
Germany Tel: +49 241 523030

India Tel: +91 80 67877200
China Tel: +86 10 8251 6588
Singapore Tel: +65 6595 6388



Distributed by:

Kenelec Scientific Pty Ltd
1300 73 22 33
sales@kenelec.com.au
www.kenelec.com.au