



Rev. 1 | 2015.04

## ART Infrared Refrigerant Transmitter

# TABLE OF CONTENTS

<b>1 POLICIES</b> .....	<b>5</b>
1.1 Important Note.....	5
1.2 Warranty Policy.....	6
1.3 Service Policy.....	6
1.4 Copyrights.....	7
1.5 Disclaimer.....	7
1.6 Revisions.....	8
<b>2 INTRODUCTION</b> .....	<b>9</b>
2.1 General Description.....	9
2.2 Key Features.....	9
<b>3 DETECTION OPTIONS</b> .....	<b>10</b>
3.1 Broadband Gas Detection.....	10
3.2 Gas Specific Detection.....	11
3.3 Changing Gas Types and Accuracy.....	13
3.4 Remote Controller Options.....	14
<b>4 INSTRUMENT SPECIFICATIONS</b> .....	<b>14</b>
4.1 Technical Specifications.....	14
4.2 Enclosure Dimensions.....	17
<b>5 FEATURES</b> .....	<b>18</b>
5.1 Front Exterior Enclosure .....	18
5.2 Interior System Layout .....	20
5.2.1 Front of Enclosure .....	20
5.2.2 Back of Enclosure.....	21
<b>6 MOUNTING</b> .....	<b>22</b>
6.1 Warnings and Prerequisites.....	22
6.2 Mounting Locations .....	23
6.2.1 General Placement Guidelines.....	23
6.2.2 Machinery Rooms.....	23

---

6.2.3 Refrigerated Spaces .....	24
6.2.4 Chillers.....	24
6.3 Mounting Procedure .....	25
<b>7 WIRING AND CONFIGURATION .....</b>	<b>28</b>
7.1 Overview.....	28
7.2 Wiring Supply Power (24 VAC or 24 VDC).....	28
7.2.1 Maintaining Neutral Polarity .....	30
7.3 Wiring Alarm Output (Analog Signal).....	30
7.4 Wiring Digital Alarm Output Relay .....	31
7.5 Modbus Network Configuration .....	32
7.6 Conclusion .....	35
<b>8 OPERATION AND STABILIZATION .....</b>	<b>36</b>
8.1 Power Up and Warm-up.....	36
8.2 Stabilization.....	36
8.3 Perform a Manual Zero.....	36
8.4 Behavior During Alarm Conditions .....	37
8.5 Gas Detector Faults .....	37
8.5.1 Overview .....	37
8.5.2 Non-Critical Faults .....	37
8.5.3 Critical Faults .....	38
<b>9 SETTING AND CONFIGURING THE PARAMETERS.....</b>	<b>39</b>
9.1 User Interface Overview .....	39
9.2 Setting Parameters .....	40
9.2.1 Overview .....	40
9.2.2 Configuring Parameters.....	40
9.3 Completing Setup .....	48
<b>10 FUNCTIONAL TESTS AND GAS ADJUSTMENTS.....</b>	<b>49</b>
10.1 Warnings and Cautions .....	49
10.2 Bump Test vs Adjusting Detector Response .....	50
10.3 Bump Testing .....	51

---

10.4 Adjustment Using Calibration Gas.....	52
<b>11 MODBUS COMMUNICATIONS.....</b>	<b>54</b>
11.1 Introduction.....	54
11.2 Communication Settings.....	55
11.3 Analog Input Registers.....	55
11.4 Analog Output Registers.....	56
11.5 Input Status Flags.....	57
11.6 Output Status Flags.....	58
<b>12 REPLACEMENT PARTS AND ACCESSORIES .....</b>	<b>59</b>
12.1 Splash Guard.....	59
12.1.1 Splash Guard Mounting Template.....	60
12.2 Metal Protective Guard .....	61
12.3 Calibration Kit.....	62
<b>13 TROUBLE SHOOTING .....</b>	<b>62</b>
13.1 Fault Codes.....	62
13.2 Diagnostic Attributes (P-18).....	65
13.3 Resetting to Default Values.....	66

# 1 POLICIES

## 1.1 Important Note

Read and understand this manual prior to using this instrument. Carefully read the warranty policy, service policy, notices, disclaimers and revisions on the following pages.

This product must be installed by a qualified electrician or factory trained technician and according to instructions indicated in this manual. This instrument should be inspected and calibrated regularly by a qualified and trained technician. For more information, refer to Section 10 *Functional Tests and Gas Adjustments* of this manual.

This instrument has not been designed to be intrinsically safe. For your safety, **do not** use it in classified hazardous areas (explosion-rated environments).

**INSTRUMENT SERIAL NUMBER:**

---

**PURCHASE DATE:**

---

**PURCHASED FROM:**

---

## 1.2 Warranty Policy

Critical Environment Technologies Canada Inc. (CETCI), also referred to as the manufacturer, warrants this instrument, (excluding sensors, battery packs, batteries, pumps and filters) to be free from defects in materials and workmanship for a period of **two years from the date of purchase from our facility**. The sensors have a warranty period of **one year on a pro-rated basis from the date of purchase from our facility**. If the product should become defective within this warranty period, we will repair or replace it at our discretion.

The warranty status may be affected if the instrument has not been used and maintained per the instructions in this manual or has been abused, damaged, or modified in any way. This instrument is only to be used for purposes stated herein. The manufacturer is not liable for auxiliary interfaced equipment or consequential damage.

Due to ongoing research, development, and product testing, the manufacturer reserves the right to change specifications without notice. The information contained herein is based on data considered accurate. However, no warranty is expressed or implied regarding the accuracy of this data.

All goods must be shipped to the manufacturer by prepaid freight. All returned goods must be pre-authorized by obtaining a Returned Merchandise Authorization (RMA) number. Contact the manufacturer for a number and procedures required for product transport.

## 1.3 Service Policy

CETCI maintains an instrument service facility at the factory. Some CETCI distributors / agents may also have repair facilities; however, CETCI assumes no liability for service performed by anyone other than CETCI personnel.

Repairs are warranted for 90 days after date of shipment (sensors have individual warranties).

Should your instrument require non-warranty repair, you may contact the distributor from

whom it was purchased or you may contact CETCI directly.

Prior to shipping equipment to CETCI, contact our office for an RMA #. All returned goods must be accompanied with an RMA number.

If CETCI is to do the repair work, you may send the instrument, prepaid, to:

**Attention: Service Department**  
**Critical Environment Technologies Canada Inc.**  
**Unit 145, 7391 Vantage Way**  
**Delta, BC, V4G 1M3**

Always include your Returned Merchandise Authorization (RMA) number, address, telephone number, contact name, shipping / billing information, and a description of the defect as you perceive it. You will be contacted with a cost estimate for expected repairs, prior to the performance of any service work.

For liability reasons, CETCI has a policy of performing all needed repairs to restore the instrument to full operating condition.

Pack the equipment well (in its original packing if possible), as we cannot be held responsible for any damage incurred during shipping to our facility.

## 1.4 Copyrights

This manual is subject to copyright protection; all rights are reserved. Under international and domestic copyright laws, this manual may not be copied or translated, in whole or in part, in any manner or format, without the written permission of CETCI.

## 1.5 Disclaimer

Under no circumstances will CETCI be liable for any claims, losses or damages resulting from or arising out of the repair or modification of this equipment by a party other than CETCI service technicians, or by operation or use of the equipment other than in accordance

with the printed instructions contained within this manual or if the equipment has been improperly maintained or subjected to neglect or accident. Any of the forgoing will void the warranty.

Under most local electrical codes, low voltage wires cannot be run within the same conduit as line voltage wires. It is CETCI policy that all wiring of our products meet this requirement.

It is CETCI policy that all wiring be within properly grounded (earth or safety) conduit.

## 1.6 Revisions

This manual was written and published by CETCI. The manufacturer makes no warranty or representation, expressed or implied including any warranty of merchantability or fitness for purpose, with respect to this manual.

All information contained in this manual is believed to be true and accurate at the time of printing. However, as part of its continuing efforts to improve its products and their documentation, the manufacturer reserves the right to make changes at any time without notice. Revised copies of this manual can be obtained by contacting CETCI or visiting [www.critical-environment.com](http://www.critical-environment.com).

Should you detect any error or omission in this manual, please contact CETCI at the following address:

### **Critical Environment Technologies Canada Inc.**

Unit 145, 7391 Vantage Way, Delta, BC, V4G 1M3, Canada

Toll Free: +1.877.940.8741

Telephone: +1.604.940.8741

Fax: +1.604.940.8745

Email: [marketing@cetci.com](mailto:marketing@cetci.com)

Website: [www.critical-environment.com](http://www.critical-environment.com)



In no event will CETCI, its officers or employees be liable for any direct, special, incidental or consequential damages resulting from any defect in any manual, even if advised of the possibility of such damages.

## 2 INTRODUCTION

### 2.1 General Description

Thank you for purchasing our ART Infrared Refrigerant Transmitter. The ART is a non-dispersive infrared, state-of-the-art fixed gas detector which can detect a wide range of refrigerant gases. It can be used on a stand-alone basis, connected to a controller or integrated into a Building Management System (BMS).

The ART can be used in locations that require continuous monitoring and to add gas detection solutions to an existing system.

The ART is available in two models - Broadband and Gas Specific. The Broadband Gas Detector is used as a general purpose, gross leak detector and is factory tested and certified. If more accurate detection is needed, Gas Specific models are available, which are factory certified and calibrated to the target refrigerant.

If after reading through the manual, you have any questions, please do not hesitate to contact our service department for technical support.

### 2.2 Key Features

- Long-life, non-dispersive infrared sensor allows for accurate low-level leak detection
- Fast-responding, refrigerant-specific sensor with no cross interferences to non-refrigerant gases
- Detects all refrigerants (CFC, HCFs, HCFC, HFOs) including HF01234yf, HF01234ze, R410a & R22)
- Modbus RTU interface to connect to BAS/BMS systems

- On-board alarm relay
- User selectable analog output: 4 - 20 mA, 0 - 5V, 1 - 5V, 0 - 10V, 2 - 10V
- LED real-time display with on-board audible and visual alarms

## 3 DETECTION OPTIONS

The ART gas detector is available in two models:

- Broadband Gas Detector used for gross leak detection, or
- Gas Specific Detector that is more distinct, pre-calibrated and characterized for response to specific refrigerants

### 3.1 Broadband Gas Detection

The ART Broadband Gas Detector (Part Code: ART-B) is used as a general purpose gross leak detector and is factory tested and certified. The refrigerants are combined into three groups and is shipped with the accuracy indicated in the chart on the next page. Measurement performance is based on an average response profile for all of the gases within the group. For more information on Value for Parameter 11, see Section 9 *Setting and Configuring the Parameters*.

GROUP #	VALUE FOR PARAMETER 11	REFRIGERANT	AS SHIPPED ACCURACY
1	P.-11 = 1	R123	±30 PPM ±35%
		R134a	±30 PPM ±25%
		R404a	±30 PPM ±35%
		R407a	±30 PPM ±25%
		R407c	±30 PPM ±20%
		R407f	±30 PPM ±20%
		R410a	±30 PPM ±20%
		R427a	±30 PPM ±15%
		R507	±30 PPM ±35%
2	P.11 = 2	R422a	±30 PPM ±25%
		R422d	±30 PPM ±20%
		HF01234yf	±30 PPM ±25%
		HF01234ze	±30 PPM ±25%
3	P.-11 = 3	R22	±30 PPM ±25%

**NOTE:** Greater accuracy may be achieved through the use of calibration gas and the adjustment procedure detailed in Section 10 *Functional Tests and Gas Adjustments*.

### 3.2 Gas Specific Detection

If more accurate detection is needed, the ART Gas Specific Detector is shipped factory certified and calibrated to the target refrigerant. For more information on Parameter 11 and refrigerant configuration instructions, see Section 9 *Setting and Configuring the Parameters*.

PART NUMBER	REFRIGERANT	ACCURACY
ART-R22	R22	$\pm 30$ ppm $\pm 5\%$
ART-R123	R123	$\pm 30$ ppm $\pm 5\%$
ART-134A	R134a	$\pm 30$ ppm $\pm 5\%$
ART-R404A	R404a	$\pm 30$ ppm $\pm 5\%$
ART-R407A	R407a	$\pm 30$ ppm $\pm 3\%$
ART-R407C	R407c	$\pm 30$ ppm $\pm 3\%$
ART-R407F	R407f	$\pm 30$ ppm $\pm 3\%$
ART-R410A	R410a	$\pm 30$ ppm $\pm 3\%$
ART-R422A	R422a	$\pm 30$ ppm $\pm 5\%$
ART-R422D	R422d	$\pm 30$ ppm $\pm 5\%$
ART-R427A	R427a	$\pm 30$ ppm $\pm 3\%$
ART-R507	R507	$\pm 30$ ppm $\pm 5\%$
ART-HF01234YF	HF01234yf	$\pm 30$ ppm $\pm 5\%$
ART-HF01234ZE	HF01234ze	$\pm 30$ ppm $\pm 5\%$

**NOTE:** Gas specific detectors can be re-calibrated in the field to new target gases. Use optional calibration instructions in Section 10 *Functional Tests and Gas Adjustments* for increased accuracy when detecting a new target gas that is different from the “as shipped” target gas. Refer to Section 3.3 *Changing Gas Types and Accuracy* below.

### 3.3 Changing Gas Types and Accuracy

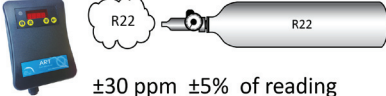
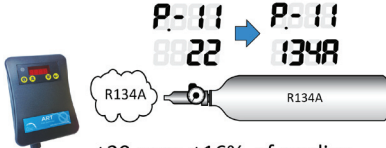
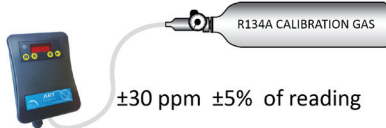
<b>As Shipped</b>	<p>The ART-R22 is factory calibrated to R22 and has an AS-SHIPPED R22 response accuracy of <math>\pm 30 \text{ ppm} \pm 5\%</math> of reading.</p>  <p><math>\pm 30 \text{ ppm} \pm 5\%</math> of reading</p>
<b>Changed Gas Type (Reduced Accuracy)</b>	<p>The gas detector may be changed to respond to any of the other listed refrigerants (see Parameter P.-11 in Section 9.2 <i>Setting Parameters</i>). If changed, the gas detector will have a lower accuracy for the target refrigerant (without calibration). In this example, that accuracy is <math>\pm 30 \text{ ppm} \pm 16\%</math> of reading.</p>  <p><math>\pm 30 \text{ ppm} \pm 16\%</math> of reading</p>
<b>Optional Calibration (For Improved Accuracy)</b>	<p>By applying calibration gas containing the NEW target refrigerant, and via the routine described in Section 10.4 <i>Adjustment Using Calibration Gas</i>, the gas detector may then be adjusted to respond with the calibrated accuracy of <math>\pm 30 \text{ ppm} \pm 5\%</math> of reading as shown in the chart in Section 3.2 <i>Gas Specific Detection</i>.</p>  <p><math>\pm 30 \text{ ppm} \pm 5\%</math> of reading</p>

### 3.4 Remote Controller Options

The ART can connect to any controller through the standard analog output (voltage and current: see 4.1 *Technical Specifications* below), the standard alarm relay, or the digital Modbus RTU communications interface.

## 4 INSTRUMENT SPECIFICATIONS

### 4.1 Technical Specifications

#### GAS TYPE

Refrigerants	
Group 1	R123, R134a, R404a, R407a, R407c, R407f, R410a, R427a, R507
Group 2	R422a, R422d, HF01234yf, HF01234ze
Group 3	R22

#### MECHANICAL

Enclosure	ABS plastic with a UL flammability rating of 94V-0
Weight	180 g (0.40 lb) (6.3 oz)
Size	4.0" x 5.9" x 1.5" (102 mm x 150 mm x 40 mm)

#### ELECTRICAL

Power Requirement	24 VDC, 24 VAC, 50 - 60 Hz, 2.5 W max
Wiring	24VAC or 24VDC two-conductor shielded 14 to 22 AWG stranded within conduit

Communication: Modbus RTU over RS-485	Baud rate:	9,600 or 19,200 (selectable)
	Start bits:	1
	Data bits:	8
	Parity:	none, odd, even (programmable)
	Stop bits:	1 or 2 (programmable)
	Re-entry time:	500 ms (min time between retries)
	End of msg:	silent 3.5 characters

## INPUT / OUTPUT

Analog Outputs	4 20- mA, 0 - 5V, 0 - 10 V, 1 - 5V, 2 - 10V
Relays	One relay rated 1 A @ 24 VAC/VDC (0.5A, 125V AC UL rating)
IP Rating	Not IP rated. An accessory splash guard is available for areas requiring additional protection from wash down.

## SENSOR

Type	Infrared
Range	0 - 3,500 ppm (0 - 1,000 for R123)
Squelch*	Readings below 75 ppm are squelched by default
Response Time, $T_{90}$	< 5 minutes

## USER INTERFACE

Display	Green LED Power ON indicator and bright, alpha-numeric LED real-time display
Audible Alarm	Buzzer; enable/disable

---

Visual Alarm	Red 4-digit LED display
Alarm Delay	Selectable; 0 to 15 minutes
Fault Monitoring	Fault codes presented to user

---

## ENVIRONMENTAL

---

Operating Temperature	-30°C to 40°C (-22°F to 104°F)
Operating Humidity	5 - 90% RH non-condensing

---

## CERTIFICATIONS

---

CE / UL / CSA / IEC / EN 61010-1

---

**NOTE:** \* When filtering is disabled (see Parameter P.-19 on page 48), the unit will respond to concentrations sub -10 ppm.



## 4.2 Enclosure Dimensions

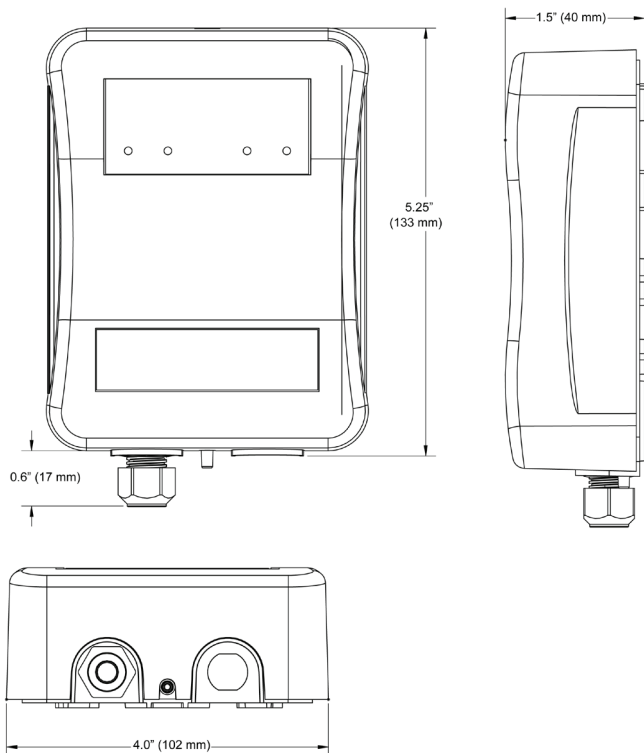

## 5 FEATURES

### 5.1 Front Exterior Enclosure



NUMBER	FEATURE	FUNCTION
1	Power LED	Green LED, indicates unit power is ON.
2	4-digit LED Display	Alpha-numeric display (to show concentration in real-time)
3	Information Button	Used to access the parameter list. Used to back up one level without writing to memory when the parameter list is active. Used to mute the audible alarm for the time period configured in parameter P-12.
4	Up Button	Used to increment the value or parameter displayed.
5	Down Button	Used to decrement the value or parameter displayed. (When the Up Button and Down Button are pressed and held together for 5 seconds, this key combination manually zeroes the gas detector.)
6	Enter/Select Button	Saves the currently displayed parameter to memory.
7	Cable Glands (2 places)	Pre-installed cable gland is on the left. The optional cable gland is on the right (if installed). See Section 7 <i>Wiring and Configuration</i> .
8	Test Gas Port	Used to connect the regulator during testing.

## 5.2 Interior System Layout

### 5.2.1 Front of the Enclosure

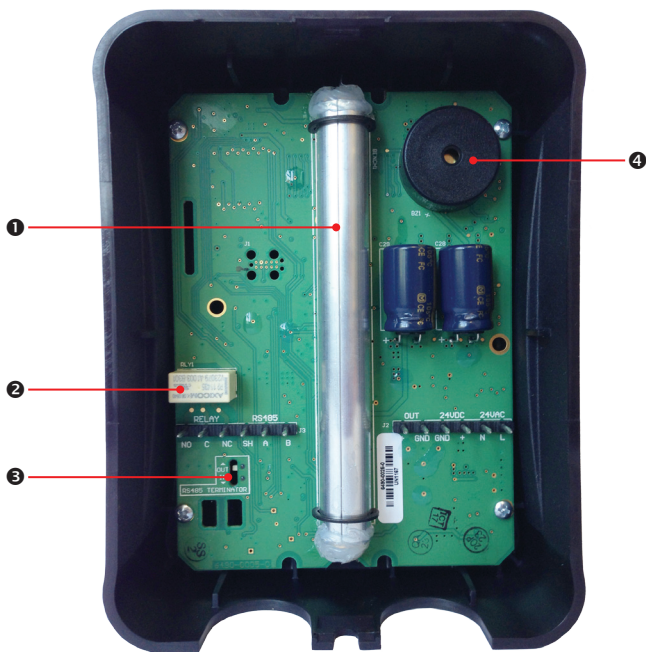

NUMBER	FEATURE	FUNCTION
1	IR Bench	Location of the Infrared sensor.
2	Relay	Pluggable terminal for relay connection.

3	Modbus end of line jumper	Critical for good communication.
4	Audible alarm	Default setting is enabled.

## 5.2.2 Back of the Enclosure

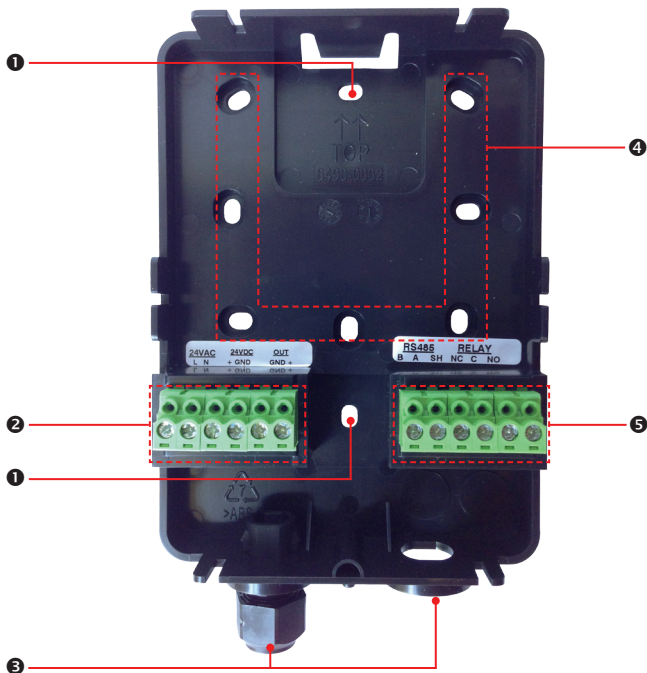

NUMBER	FEATURE	FUNCTION
1	Junction box mounting holes	Use hole pattern to mark the mounting locations as needed and attach ART base to junction box using mounting hardware through these holes.
2	Terminal Block Positions 1-6	AC, DC and Analog wiring
3	Cable Gland / Blanking Plug	Pre-installed cable gland is on the left. The optional cable gland is on the right, if installed (each with a 1/4 inch cable capacity). See Section 7 <i>Wiring and Configuration</i> .
4	Flat surface mounting holes	Use to attach ART base to wall mount or other flat surface using #6 screws provided.
5	Terminal Block Positions 7-12	Relay (alarm) output wiring and Modbus network connection wiring

## 6 MOUNTING

### 6.1 Warnings and Prerequisites

**WARNING:** Explosion hazard. DO NOT mount the ART in an area that may contain flammable liquids, vapors, or aerosols. Operation of any electrical equipment in such an environment constitutes a safety hazard.

#### CAUTION:

- The ART contains sensitive electronic components that can easily be damaged. DO NOT touch or disturb any of these components.

- DO NOT mount the ART directly to vibrating machinery as the vibrations may degrade the gas detector's performance.

## NOTES:

- The mounting location of the monitor should allow it to be easily accessible for visual monitoring and servicing.
- The monitor must be connected to a marked, suitably located and easily reached switch or circuit-breaker as means of disconnection.
- Connect monitor power and signaling terminals using wiring that complies with local electrical codes or regulations for the intended application.

## 6.2 Mounting Locations

### 6.2.1 General Placement Guidelines

The ART should be installed plumb and level and securely fastened to a rigid mounting surface. Gas detectors must be located within the appropriate wire lengths from the central control unit (if used).

**NOTE:** When installed in areas that may be subjected to water spray, the optional splash guard should be used in conjunction with the ART.

### 6.2.2 Machinery Rooms

There is no absolute rule in determining the number of gas detectors and their locations. However, a number of simple guidelines will help to make a decision. Gas detectors monitor a point as opposed to an area. If the gas leak does not reach the detector then no alarm will be triggered. Therefore, it is extremely important to carefully select the gas detector location. Also consider ease of access for maintenance.

The size and nature of the site will help to decide which method is the most appropriate to use. Locations requiring the most protection in a machinery or plant room would be around compressors, pressurized storage vessels, refrigerant cylinders or storage rooms or pipelines. The most common leak sources are valves, gauges, flanges, joints (brazed or

mechanical), filling or draining connections, etc.

In machinery rooms where there is **little or no airflow**, placement options are:

- Point Detection, where gas detectors are located as near as possible to the most likely sources of leakage, such as the compressor, expansion valves, mechanical joints or cable duct trenches.
- Perimeter Detection, where gas detectors completely surround the area or equipment.
- Halocarbon and hydrocarbon refrigerants are heavier-than-air gases and as such the gas detectors should be located near ground level (6 to 18 inches from the floor).

**NOTE:** Gas detectors should be positioned just far enough back from any high-pressure parts to allow gas clouds to form and be detected. Otherwise, a gas leak might pass by in a high-speed jet and not be detected by the gas detector.

- Make sure that pits, stairwells and trenches are monitored since they may fill with stagnant pockets of gas.
- For racks or chillers pre-fitted with refrigerant gas detectors, these should be mounted so as to monitor the compressors.
- Do not mount the gas detector directly to pipes or structures that are subject to strong vibration.

### 6.2.3 Refrigerated Spaces

In refrigerated spaces, gas detectors should be located away from doors, in the return airflow to the evaporators on a sidewall (below head-high is preferred), or on the ceiling, not directly in front of an evaporator, nor in any direct airflow. In large rooms with multiple evaporators, gas detectors should be mounted on the central line between two adjacent evaporators, as turbulence will result in airflows mixing.

### 6.2.4 Chillers

In the case of small water- or air-cooled enclosed chiller units mount the gas detector so as to monitor airflow to the extract fans. With larger models also place a gas detector inside



the enclosure under or adjacent to the compressors.

For enclosed air-cooled chillers or the outdoor unit for variable refrigerant volume and variable refrigerant flow (VRV/VRF) systems, mount the gas detector so as to monitor airflow to the extract fan. With large units also place a gas detector inside the enclosure under or adjacent to the compressors.

### 6.3 Mounting Procedure

To open the housing as received, use a flat blade screwdriver and depress the top latch. While pushing the latch grasp the back edge of the housing near the latch and pull the back away.

When mounted, the housing is simply opened by pressing the top latch with a suitable screwdriver or other flat blade. With the top latch depressed pull the housing apart by grasping the sides and pulling straight out. With the housing separated the mounting base with terminal blocks will be visible.

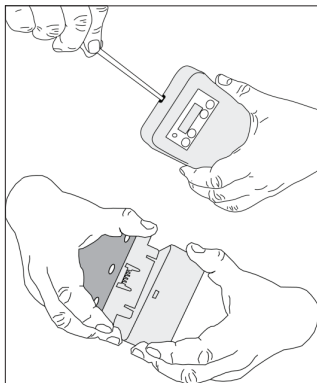

**NOTE:** Do not apply caulking or other material around the gas detector base. The gas detector relies on air exchange through the spaces between the base and the gas detector housing. Do not obstruct the small gap around the housing and the base with any material.

**Step 1:**

Open the housing.

**Step 2:**

Position the base to the pre-determined (acceptable) mounting location. Use the gas detector base to mark the mounting location as needed. The hole pattern on the back plate is sized to mount the gas detector onto various electrical junction boxes. The other holes may be used as needed to mount the gas detector to other structures, or onto a wall.

**Step 3: Wall Mount** (if doing a junction box mount, go to Step 4)

Attach the ART base to the mounting surface using two #6 screws (provided) through two of the 7 flat surface mounting holes, being careful not to over-tighten the screws.

**Step 4: Junction Box Mount** (if doing a wall mount, see Step 3)

Attach the ART base to the junction box (using mounting hardware provided with your junction box) through the two junction box holes. See diagram above.

**Step 5:**

Unless you are ready to wire the device (see Section 7 *Wiring and Configuration*) carefully snap the cover onto the base unit.

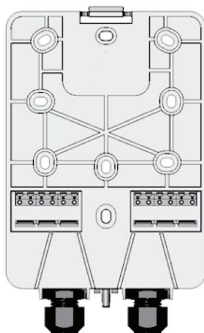
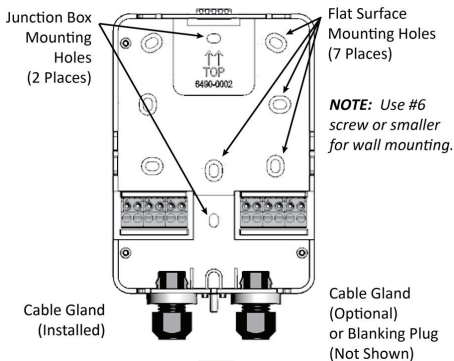

## 7 WIRING AND CONFIGURATION

### 7.1 Overview

Prior to wiring and configuring the ART, assure the following conditions have been met:

- ART back plate is mounted in an appropriate location
- The cover panel is removed.

If the cover panel was reattached after mounting, open the gas detector enclosure by pressing the top latch with a suitable screwdriver or other flat blade. With the top latch depressed pull the housing apart by grasping the sides and pulling straight out. Align and press together to close.

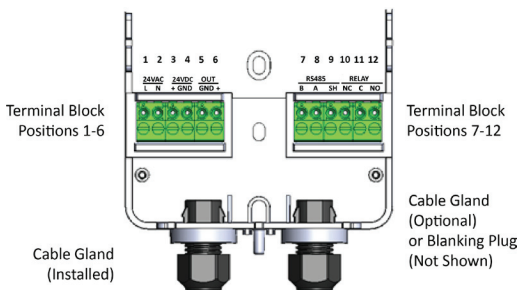

#### NOTES:

- The pre-installed cable gland (left) and optional cable gland (right) have a 1/4 inch cable capacity (each).
- Install the optional cable gland on the right side of the base unit if needed. Otherwise, install the blanking plug that is included in the mounting kit.

### 7.2 Wiring Supply Power (24 VAC or 24 VDC)

**WARNING:** Incorrect wiring may permanently damage the gas detector, and void the

warranty. Double check all terminations before applying power.

All wiring should be run within properly grounded (earth or safety) conduit. Low voltage wiring must not be within the same conduit as line voltage wiring.

Either 24 VAC or 24 VDC may be used to power the ART. Connect wiring to the appropriate terminal locations. Use 2 wires between 14 and 22 AWG.

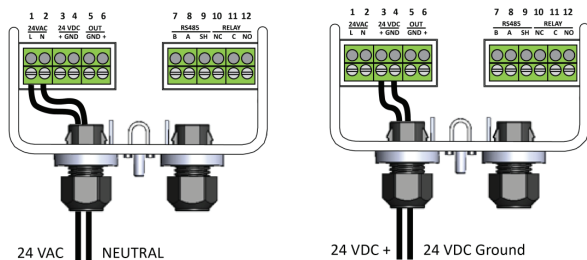

POWER OPTION	PIN	LABEL	WIRING TERMINATION
24 VAC	1	L	24V AC line
	2	N	24V AC neutral
24 VDC	3	+	24V DC positive
	4	GND	24V DC ground

The ART must be powered by either:

- A suitable UL 60950/CSA certified power supply that is isolated from line voltage by double insulation, or
- An appropriately rated UL listed/CSA Class 2 transformer.

Failure to comply can result in personal injury or death.

## 7.2.1 Maintaining Neutral Polarity

Neutral polarity must be maintained across units.

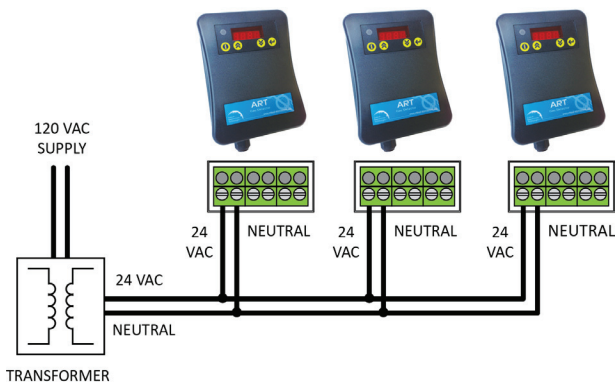

## 7.3 Wiring Alarm Output (Analog Signal)

The ART provides an analog output signal that is proportional to the level of gas detected.

**NOTE:** No jumpers or hardware switch settings are required to configure the analog output. This is done electronically from the front panel display.

Connect two 18 to 20 AWG wires to terminal block positions 5 and 6, noting ground and signal polarity shown in Section 7.2.1 *Maintaining Neutral Polarity*.

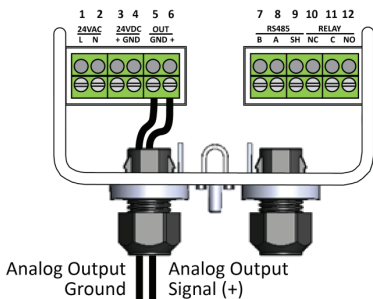

FUNCTION	PIN	WIRING TERMINATION
Analog Output	5	Analog output ground
	6	Analog output signal (+)

The type of output signal on pins 5 and 6 is programmable using the analog output type parameter P-03. Refer to Section 9 *Setting and Configuring the Parameters* for details.

## 7.4 Wiring Digital Alarm Output Relay

An alarm setpoint may be programmed from the front panel of the ART. When the sensed gas level exceeds the alarm setpoint, the ART enters the alarm state. An on-board relay is tied to the alarm state, so you may activate (or deactivate) external equipment based on the ART's current alarm status.

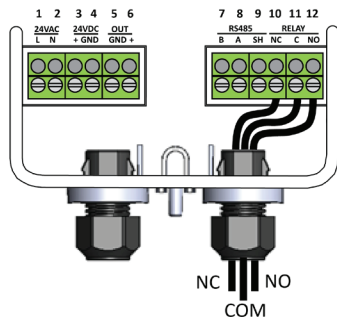

**NOTE:** The relay can be programmed to be failsafe (normally energized). By default, the relay is set to be normally de-energized. This can be set using parameter P-06.

Make relay connections (NO, NC, or both) using 18 to 20 AWG wires to terminal block positions 10, 11, and 12, noting normally open, normally closed, and common connectors.

FUNCTION	PIN	WIRING TERMINATION
Relay (Alarm) Output	10	Relay NC contact
	11	Relay common contact
	12	Relay NO contact

## 7.5 Modbus Network Configuration

If your application includes a Modbus network, make network connections (RS-485 A and RS-485 B) using 18 to 24 AWG shielded twisted pair wires (with 120 ohm characteristic impedance) to terminal block positions 7 and 8, noting inverted B (-) and non-inverted A (+) signal connectors.



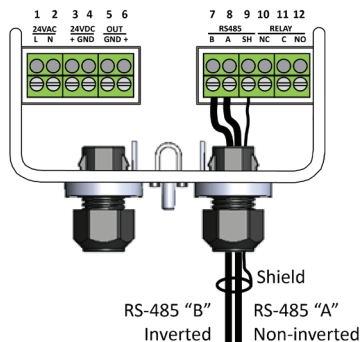

FUNCTION	PIN	WIRING TERMINATION
Modbus Network Communications	7	RS-485 "B" (inverted)
	8	RS-485 "A" (non-inverted)
	9	RS-485 shield

**NOTE:** For Modbus network communications wiring, use only 18 to 24 AWG shielded twisted pair wire with 120 ohm characteristic impedance.

Connect the RS-485 cable shield pin 0 (board ground).

Selection of the Modbus Address and Baud Rate is completed through the gas detector setup menu, described later. No jumpers or hardware switch settings are required to configure the Modbus communications network. This is done electronically from the front panel display.

For Modbus communications with the ART, the default communications parameters are as follows:

- Baud rate = 9,600
- Parity = no parity
- Stop bits = 1

Confirm that all devices on the Modbus communications network (including a Building Management System) are configured similarly.

If the ART is at the end of the RS-485 network, then be sure to set the RS-485 terminator on the printed circuit board (PCB) to IN. This applies a terminating resistor to the end of the wires per the requirements of the RS-485 protocol. The terminator should be set to OUT for all other installation conditions.

Be sure to enable the termination resistor on the device at each end of the network. This includes the Building Management System (if used).

**NOTE:** Care should be exercised when changing the terminator switch. Before powering the gas detector, use a fine pointed device or paper clip to slide the switch position. Do not apply force to the switch or push on the switch with any device. The switch changes position up and down along the access slot direction.

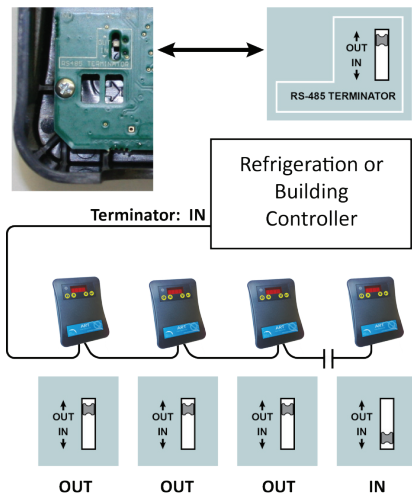

## 7.6 Conclusion

Once the base is mounted and all wiring is complete, align the gas detector housing and press it onto the base. The gas detector will snap into position, completing all electrical connections. Ensure the top and bottom snap locks are engaged.

### NOTES:

- If the right cable gland was not needed during installation and wiring, be sure to install the blanking plug.
- Do not apply caulking or other material around the gas detector base. The gas detector relies on air exchange through the spaces between the base and the gas detector housing. Do not obstruct the small gap around the housing and the base with any material.

## 8 OPERATION AND STABILIZATION

### 8.1 Power Up and Warm-up

On powering up, the ART will sense for the presence of gas after an initial warm-up period of 2 to 5 minutes. The green LED will flash at a 1 second interval during the warm-up.

### 8.2 Stabilization

It is vital when first installing the gas detector that it warms up in an atmosphere that is known not to contain any background concentrations of refrigerant.

### 8.3 Perform a Manual Zero

After the gas detector stabilizes, the power LED stops flashing and is lit continuously. CETCI recommends manually zeroing the ART after a 1-hour stabilization period.

To manually zero the gas detector, press and hold the UP and DOWN buttons simultaneously for 5 seconds. The gas detector will beep and the display will show "ZERO" when zeroing is complete. The display will show FAIL if the temperature is changing too quickly or there is an active alarm condition.

#### NOTES:

- Manual zero should be performed in the environment of operation and at the typical operating temperature.
- Subsequent manual zeroes may be performed, provided the atmosphere around the gas detector is free of all background concentrations of refrigerant. Clean air or nitrogen applied to the calibration port for five minutes may be used to ensure the gas detector is clear of all background gas. Re-zeroing with background refrigerant present will cause the gas detector to report incorrect readings.

## 8.4 Behavior During Alarm Conditions

The following occurs during an alarm condition:

ITEM	BEHAVIOUR DURING ALARM STATE
Green LED	ON (solid)
Display	ON (blinks), reports detected ppm concentration
Audible Alarm	ON (if enabled and after programmed delay expires)
Relay Output	Activates (after any programmed delay expires)
Analog Output	Changes proportionally with gas concentration (as configured)
Modbus Registers	Registers indicate the alarm condition, ppm concentration, etc.

**NOTE:** The alarm feature includes a 20% dead band to prevent alarm 'chatter' if the concentration hovers near the alarm set point. Once the alarm has been triggered it will remain latched until the concentration drops below 80% of the alarm setpoint.

## 8.5 Gas Detector Faults

### 8.5.1 Overview

There are two levels of faults monitoring built into the ART gas detector:

- Non-critical
- Critical

### 8.5.2 Non-Critical Faults

Non-critical faults typically recover by allowing the gas detector surroundings to stabilize, for example, after a defrost cycle. The gas detector continues to monitor its surroundings during non-critical faults, but may report inaccurate readings.

The following occurs when a non-critical fault condition exists:

<b>ITEM</b>	<b>BEHAVIOUR DURING ALARM STATE</b>
Green LED	ON (solid)
Display	Shows the appropriate fault code
Analog Output	Operates normally
Modbus Registers	Modbus registers indicate the fault

### 8.5.3 Critical Faults

Critical faults may indicate an unrecoverable condition. Please refer to Section 13 *Troubleshooting* for more information. The following occurs when a critical fault condition exists:

<b>ITEM</b>	<b>BEHAVIOUR DURING ALARM STATE</b>	
Green LED	OFF (indicating the gas detector is off-line)	
Display	Shows the appropriate fault code	
Analog Output	4 - 20 mA output	Changes to 2 mA
	1 - 5V output	Changes to 0.5V
	2 - 10V output	Changes to 1.0V
Modbus Registers	Modbus registers indicate the fault	

## 9 SETTING AND CONFIGURING THE PARAMETERS



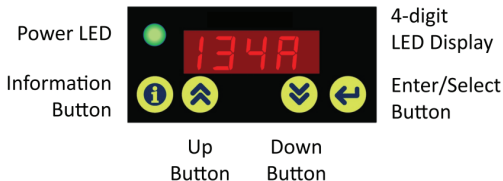

### 9.1 User Interface Overview

The ART Gas Detector is configured through the built-in menu system. Once mounting is complete, attach the gas detector to the base and apply power.

The user interface consists of four pushbuttons, a four digit LED numeric display, and a power LED. When the display is off, press any button to wake the display for 10 seconds.



Buttons functions:

BUTTON	BEHAVIOR DURING ALARM STATE
	Used to access the parameter list. Used to back up one level without writing to memory when the parameter list is active. Used to mute the audible alarm for the time period configured in parameter P.-12.
	Used to increment the value or parameter displayed.
	Used to decrement the value or parameter displayed.
 + 	When pressed together and held for 5 seconds, this key combination manually zeroes the gas detector.



Saves the currently displayed parameter to memory.

## 9.2 Setting Parameters

### 9.2.1 Overview

Press and hold the information button (ⓘ) for 5 seconds to activate the parameter list. Each parameter is shown in turn by using the UP or DOWN buttons. The parameter is shown as P-XX, with XX being the parameter value. Pressing Enter while a parameter is displayed allows the attributes of the parameter to be set. Each Parameter has its own attributes, as shown in the table below. Set the attributes as desired, and then press Enter to save the setting.

### 9.2.2 Configuring Parameters

PARAMETER	DESCRIPTION
<b>P-01</b>	<p><b>Maintenance Mode</b> Sets gas detector to offline mode for 30 minutes.</p> <ul style="list-style-type: none"> <li>00 Gas detector is online, with normal response to its surroundings (default)</li> <li>01 Gas detector is offline and suppresses all outputs. Display reads “oFFL” (offline) during 30 minute timeout.</li> </ul>
<b>P-02</b>	<p><b>Alarm Set Point</b> Sets desired ppm value (range 75 to 3,500 ppm) above which alarm occurs. Use UP or DOWN buttons. For faster “coarse” adjustment, hold either button to sweep through the adjustment range quickly. Default set point is 250 ppm for all gases except R123 where the default is 35 ppm.</p>



**P-03****Analog Output Type**

Selects output type:

- 00 Selects 0-5 V
- 01 Selects 1-5 V
- 02 Selects 0-10 V
- 03 Selects 2-10 V
- 04 Selects 4-20 mA (default)

**P-04****Alarm ON Delays**

Sets the ON delay time (0-15 minutes) for the alarm output signals (relay, Modbus). The default delay is 0 minutes.

**P-05****Alarm OFF Delays**

Sets the OFF delay time for the alarm output signals (relay, Modbus) in minutes (0-15). The default delay is 0 minutes.

**P-06****Relay Contact Behavior (Failsafe Mode)**

Sets the default relay power state so that power loss can be detected. The behavior of the relay changes from energizing when an alarm condition occurs (default) to energizing at power up (Failsafe). In both cases the relay changes state when an alarm occurs, failsafe is simply inverted. This allows power failures to be detected as alarms.

- 00 NO
- 01 Failsafe mode (default mode)

**P-07****Relay Latching**

Controls the relay latching behavior.

- 00 OFF (default). Relay does not latch and resets once the alarm condition is removed.
- 01 ON. Relay remains latched; reset by BMS command over RS-485 or by pressing and holding the ENTER button for 5 seconds.

**P-08****Audible Alarm**

The units have an internal audible alarm. You can disable this, but the default setting is “enabled” in compliance with EN378.

00	OFF
01	ON (default)

**P-09****Display Mode**

The display can be turned on by using this parameter. When set to ON the display never shuts off (all operating modes). When ON the display shows the current gas concentration (or 0 if below the squelch). Note that P.-09 is disabled if P.-19=0.

00	OFF during normal operation when the ppm value is below the alarm set point
01	ON (default)

*In either case, the display will blink the measured ppm value during an alarm state.*

**P-10****RS485 Node Address**

Sets the RS-485 node address (0001 to 0255).

**P-11****Gas Groups / Specific Gas Selection**

Selects either gas group number for broadband operation or specific gas name for gas-specific mode.

Broadband: Select from 3 groups of gases:

- 1 R134a, R404a, R407a, R407c, R407f, R427a, R507
- 2 R422a, R422d HFO1234YF, and HFO1234Ze
- 3 R22 (by itself)

Specific Gas: The actual refrigerant name is shown. Select the appropriate refrigerant.

**NOTE:** Gas-specific detectors are factory calibrated to a single refrigerant using specialized manufacturing equipment. If another refrigerant is selected which differs from the factory calibrated setting, the built in calibration no longer applies. Further improvement in detector accuracy may be gained by applying calibration gas containing the newly selected refrigerant and adjusting the gas detector reading to match (see Parameter P.-17).

**P-12****Buzzer Mute Time**

Sets a time (0-59 minutes) during which the active buzzer remains muted:

- after the "I" button is pressed, or
- after Modbus register 4000 is set to 0

**P-13****Baud Band**

Sets the baud rate for Modbus (RS-485) communications.

- |    |                      |
|----|----------------------|
| 00 | 9,600 baud (default) |
| 01 | 19,200 baud          |

**P-14****Stop Bits**

Sets the number of stop bits required to match the controlling communications equipment (e.g., building management system, etc.).

- |    |                      |
|----|----------------------|
| 01 | 1 stop bit (default) |
| 02 | 2 stop bits          |

**P-15****Parity**

Sets Modbus parity option.

- |    |                |
|----|----------------|
| 00 | None (default) |
| 01 | Odd parity     |
| 02 | Even parity    |

**P-16****Analog Output Scaling**

Allows the user to select the full-scale ppm value that represents maximum analog output (e.g., 20 mA) for scaling the analog output. Adjustment range is from 100 to 3,500 ppm. Default = 3,500 ppm. (The setting cannot be adjusted above 3,500.)

Use the Up and DOWN buttons to set the desired full scale value. All outputs will be scaled to the indicated full scale value.

**NOTES:**

- Alarm values are not scaled, but are absolute values. Setting a smaller full scale does not correspondingly scale the alarm setting.
- When the ppm level is greater than the programmed analog output Full Scale ppm (P-16), the analog output will go to a 10% over range state (indicating that the concentration is too high for the analog output to achieve). For example, for a 1-5 V setting the analog output would go to 5.5 V, for 4 20 mA it would go to 22 mA and so on.

The analog output signal range is from 100 ppm to the default value of 3500 ppm, which is scaled across the actual output range selected by the analog output type parameter P.-03. The upper ppm limit is programmable using analog output scaling parameter P.-16. This parameter sets the full scale ppm value creating a ppm range across which the analog output is scaled.

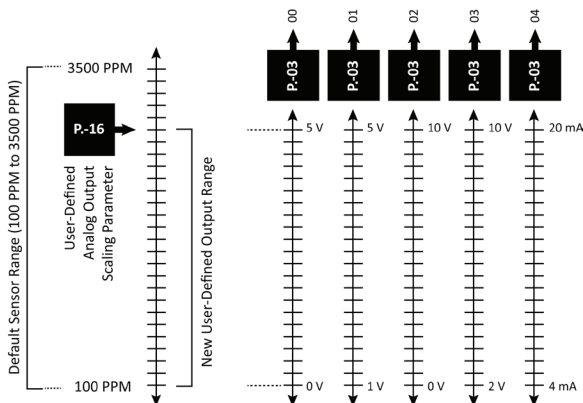

PARAMETER	DESCRIPTION
	<b>Gas Test Mode</b> Places the gas detector in gas test mode. <ul style="list-style-type: none"><li>00 Disabled (default)</li><li>01 Enabled</li></ul> <p>When enabled, the display continuously cycles through the following:</p> <ul style="list-style-type: none"><li>- CAL is displayed briefly.</li><li>- Next, the gas group number or gas type (based on product code) is displayed.</li><li>- Then four dashes (----) are displayed.</li></ul> <p>After gas is applied and the 75 ppm squelch level is exceeded, the live concentration replaces the four dashes. See Section 10.4 <i>Adjustment Using Calibration Gas</i> if using Gas Test Mode to initiate the calibration procedure.</p> <p><b>NOTE:</b> To prevent false alarms, all outputs are suspended while Test Mode is active. The only live indication is the 4-digit display. Once the gas test mode is enabled to perform a gas test or calibration, the unit will automatically go offline for a ten minute period after the parameter list is exited. (This allows time for the test gas to clear before the unit becomes active). If no activity occurs for ten minutes, the unit exits the gas test mode.</p>



## Diagnostics Menu

Parameter 18 provides access to the self-diagnostic information. The LED display shows “DIAG” until the Enter button is pressed. Use the UP and DOWN buttons to scroll through the list of diagnostic attributes.

A.-01	Current fault condition
A.-02	Last fault
A.-03	Days in service
A.-04	Days since last adjust/test
A.-05-A.-07	Factory Use Only
A.-08	Detector temperature in °C
A.-09	Temperature rate of change
A.-10-A.-17	Factory Use Only

To aid in troubleshooting, the operator may choose to reset the gas detector to its default state by holding both the UP and DOWN buttons for 5 seconds while in the Diagnostics Menu. All settings, including the alarm set point, gas adjustments, the selected gas curve, calibration data, the Modbus address, etc. revert to specific default values after a reset.

**IMPORTANT:** Calibrations on either gas-specific or broadband models are lost after a reset. This returns the gas detector to an uncalibrated condition. See Parameter P.-17 for information on how to recalibrate the gas detector.

Refer to Section 13 *Troubleshooting* for a complete list of codes and details on the reset option.



## Response Filtering

This parameter is used to turn filtered output ON (01) or OFF (00).

The default setting is ON (01). The Modbus and analog output are filtered so that responses below 75 ppm are squelched. If the display mode (P-09) is set to ON (01) the display shows 0 for any signal level below 75 ppm.

Some installations may wish to monitor the small analog output changes that may be created by the detector environment. Turning filtering OFF (00) allows these small variations around the minimum analog output (e.g., 4 mA, 1V, etc.) to be transmitted via Modbus and the analog output terminals.

### NOTES:

- The detector display is OFF when filtering is OFF (P-09 is disabled).
- Whenever filtering is OFF the detector display will turn ON for 10 minutes if the detector is re-zeroed (see Section 8.3 *Perform Manual Zero*). This is intended to aid maintenance testing. The analog outputs continue to transmit the full, unfiltered range, and the alarm set point remains active.

## 9.3 Completing Setup

To complete the setup after all parameters are set as needed, simply press and hold the information button (ⓘ) for 5 seconds to exit the Parameter list. The gas detector is now actively monitoring its surroundings.

**NOTE:** If no buttons are pressed for 2 minutes, the ART exits setup mode automatically.



# 10 FUNCTIONAL TESTS AND GAS ADJUSTMENTS

## 10.1 Warnings and Cautions

To comply with the requirements of EN378 and the European F-GAS regulation, gas detectors must be tested annually. However, local regulations may specify the nature and frequency of this test. Check local regulations on calibration or testing requirements.

The ART contains sensitive electronic components that can be easily damaged. Neither touch nor disturb any of these components.

CETCI recommends annual checks and adjustment using calibration gas. Calibration gas adjustment frequency may be extended based on application, but should never exceed 2 years.

In applications where life safety is critical, calibration gas adjustment should be done quarterly (every 3 months) or on a more frequent basis. CETCI is not responsible for setting safety practices and policies. Safe work procedures including calibration policies are best determined by company policy, industry standards, and local codes.

Failure to test or adjust the unit in accordance with applicable instructions and with industry guidelines may result in serious injury or death. The manufacturer is not liable for any loss, injury, or damage arising from improper testing, incorrect adjustment, or inappropriate use of the unit.

Before testing the gas detectors on-site, the ART must have been powered up and allowed to stabilize.

After initial installation, the ART should be gas tested to ensure proper operation.

The testing and/or adjustment of the unit must be carried out by a suitably qualified technician, and must be done:

- In accordance with this manual

- In compliance with locally applicable guidelines and regulations

Qualified operators of the unit should be aware of the regulations and standards set down by the industry/country for the testing or calibration of this unit. This manual is only intended as a guide and, insofar as permitted by law, the manufacturer accepts no responsibility for the calibration, testing, or operation of this unit.

The frequency and nature of testing or calibration may be determined by local regulation or standards.

EN378 and the F-GAS Regulation require an annual check in accordance with the manufacturer's recommendation.

## 10.2 Bump Test vs Adjusting Detector Response

There are two concepts that need to be differentiated:

- Bump test
- Gas detector response adjustment

A bump test exposes the gas detector to a gas. The operator then observes the gas detector's response to the gas. The objectives are two-fold:

- Establishes if the gas detector is reacting to the gas
- Determines if all of the detector outputs are working correctly

There are two types of bump tests:

- Quantified - A known concentration of gas is used.
- Non-quantified - A gas of unknown concentration is used (should not exceed two times the sensor range, preferable within the sensors range of 3500 ppm).

Adjusting gas detector response exposes the gas detector to a calibration gas as well (like a quantified bump test), but additionally sets the actual gas detector response level (via Parameter P. 17) to ensure that the gas detector activates at the specified gas concentration.

Refer to the following Sections below for additional information on bump testing and gas detector response adjustment.

**CAUTION:** Before you carry out the test or adjustment:

- Advise occupants, plant operators, and supervisors.
- Check if the gas detector is connected to external systems such as sprinkler systems, plant shut down, external sirens and beacons, ventilation, etc. and disconnect as instructed by the customer.
- For bump test or calibration the ART should be powered up and fully stabilized as per Section 8 *Operation and Stabilization*.

### 10.3 Bump Testing

**NOTE:** Notify others that testing is underway. During bump testing the alarm outputs are active, and will trigger whatever response is intended. It is the operator's responsibility to ensure that such actions are acceptable and can be performed safely.

After installation and parameter setup (see Section 9 *Configuration*), the units should be bump tested. Expose the gas detector to test gas. The gas selected should be a high enough concentration to put the system into alarm and light the LED display.

With a bump test you can see the functions of the gas detector:

- The LED display will light and show the detected ppm concentration once the alarm set point is reached
- The relay and audible alarm will function as configured including any delays set (ON or OFF).
- The output (0 - 10V, for example) will show the gas level

Ideally bump tests are conducted on-site in a clean air atmosphere.

#### Step 1:

Remove the splash guard accessory if one is used.

**Step 2:**

Connect the regulator to the test gas port using 3mm or 1/8" inside diameter tubing (see below).

**Step 3:**

Expose the gas detector to gas from the cylinder. Monitor the LED display reading. Refer to Section 4.1 *Technical Specifications* for acceptance criteria.

**10.4 Adjustment Using Calibration Gas**

Every ART gas detector is calibrated in a chamber by true diffusion method prior to leaving our facility. This method more closely emulates actual “real world” conditions. Field calibration using gas cylinder, regulator and hose directing span gas into the sensor may result in slightly higher readings. It is important to note that the type of gas mixture, how old the gas is and what temperature it has been stored at will also affect repeatability during field calibration.

Adjustment using calibration gas requires a gas cylinder with the appropriate gas and concentration. Note that CETCI offers a calibration kit that consists of a calibration gas

cylinder and a flow regulation valve with flexible non-absorbent tubing.

If an inappropriate concentration of span gas is applied during calibration, calibration may succeed but it does not mean the equipment has been calibrated properly. CETCI is not responsible for improperly calibrated detectors. Follow manual instructions carefully.

**NOTE:** For improved accuracy and response, the gas detector should be protected from excess drafts while performing the adjustment. Excess air circulation may dilute the applied calibration gas and lead to lower than expected response.

### Step 1:

Connect the regulator to the test gas port using 3mm or 1/8" inside diameter tubing.

### Step 2:

Enable Parameter P.-17 Gas Test Mode (see Section 9 Configuration). When enabled, the display continuously cycles through the following:

- CAL is displayed briefly.
- Next, the gas group number or gas type (based on product code) is displayed.
- Then four dashes (----) are displayed.

After gas is applied and the 75 ppm squelch level is exceeded, the live concentration replaces the four dashes.

**NOTE:** The analog outputs, relay activity, and RS-485 ppm reporting are suspended in Gas Test Mode to prevent false alarms.

### Step 3:

Expose the gas detector to gas from the cylinder. Monitor the 4 digit LED display reading.

### Step 4:

Wait for the ppm reading to stabilize. This should take approximately 4-6 minutes. Minor changes (less than 5 ppm in 10 seconds) are considered stable readings. Compare the

response value with the calibration gas concentration.

### Step 5:

Adjust the gas detector displayed value by using the UP or DOWN buttons to increase or decrease the value shown. Adjust until the reading is within  $\pm 2\%$  of the calibration gas. For example, if the calibration gas is 1000 ppm, the gas detector is adjusted properly when the displayed reading is between 980 and 1,020 ppm.

### Step 6:

Press the Enter button to store the new adjustment. Turn off the calibration gas and remove the tubing from the calibration port.

### Step 7 :

If no further changes to the other parameters are required, press and hold the (Ⓢ) button for 5 seconds to exit the Parameter list. Upon exiting the Parameters list, the gas detector will enter offline mode for a period of 10 minutes. This allows time for the calibration gas to dissipate after testing. During offline mode, the gas detector suppresses all outputs. The display reads "oFFL" (offline) during 10 minute timeout.

**NOTE:** All calibration gas mixtures have a blend tolerance. The tolerance will limit the actual adjustment accuracy that is achievable.

## 11 MODBUS COMMUNICATIONS

### 11.1 Introduction

The ART gas detector can be configured to communicate on an RS-485 network using Modbus-RTU protocol. Before configuring the gas detector for Modbus communications, be sure your network connection is complete and your network termination switches are set appropriately. Refer to Section 7 *Wiring and Configuration*, for details.

This section details the ART parameters that can be accessed via registers of the Modbus-RTU ("Modbus") protocol. Generally (with the exception of some of the communications parameters), parameters you can access and/or configure from the front panel of the ART

can also be accessed and/or configured via a Building Management System (for example) on the same Modbus network.

## 11.2 Communication Settings

There are 255 selections available to be set electronically, from addresses 1 to 255 inclusive. Modbus data with a zero in the address field is received by all detectors (regardless of the address selected) to enable the master device to broadcast simultaneously to all the detectors.

Refer to Section 4.1 *Technical Specifications* for information on RS-485 network communications parameters such as data bits, stop bits, etc.

## 11.3 Analog Input Registers

Analog input registers are read only and use function code 04.

REG	DESCRIPTION	RANGE	UNITS	P.-##
1000	Concentration gas level	0-100	% FS	--
1001	Concentration gas level	0-65, 535	ppm	--
1002	<i>Reserved</i>			--
1003	Full scale detector level	0-65, 535	ppm	--
1004	Alarm set-point (% full scale)	0-100	%	--
1005	Gas detector timer	0-35, 535	hours	--
1006	Node address	1-247	none	P.-10
1007	Software version		none	--

1008	<i>Reserved</i>			--
1009	<i>Reserved</i>			--
1010	<i>Reserved</i>			--
1011	<i>Reserved</i>			--
1012	16-bit fault code	0-65535	none	--

## 11.4 Analog Output Registers

Analog output registers are readable (using function code 03) and writable (using function code 06).

REG	DESCRIPTION	RANGE	UNITS	P.-##
2000	Alarm set point	75-3,500	ppm	P.-02
2001	Alarm ON delay (Alarm flag register 3000 is set to 1)	0-15	min	P.-04
2002	Buzzer mute time	0-59	min	P.-12
2003	Alarm OFF Delay	0-15	min	P.-05
2004	Relay action	0=NO 1=Fail-safe	none	P.-06
2005	Relay latching enable	0=Disable 1=Enable	none	P.-07
2006	Buzzer enable	0=Disable 1=Enable	none	P.-08



2007	Display mode	0=OFF 1=ON	none	P.-09
2008	Analog output type	0=0-5V 1=1-5V 2=0-10V 3=2-10V 4=4-20 mA	none	P.-03
2009	Baud rate	0=9,600 1=19,200	none	P.-13
2010	Stop bits	1 or 2	none	P.-14
2011	Gas curve number	1 to 3 (broadband unit) or gas type (gas specific)	none	P.-11
2012	Analog output full scale ppm (R/O)	100-3,500	ppm	P.-16
2013	Parity	0=None 1=Odd 2=Even	none	P.-15

## 11.5 Input Status Flags

Input Status Flags are readable (using function code 02).

REG	DESCRIPTION	RANGE	P.-##
3000	Alarm flag (0 or 1=Alarm)	0-1	--
3001	Relay state (0 or 1=energized)	0-1	--

3002	Detector fault (0 or 1=fault)	0-1	--
3003	Red LED state (0 or 1=ON)	0-1	--
3004	Green LED state (0 or 1=powered ON)	0-1	--
3005	<i>Reserved</i>		--
3006	Startup (0=normal operation, 1=warning)	0-1	--
3007	<i>Reserved</i>		--
3008	<i>Reserved</i>		--

## 11.6 Output Status Flags

Output Status Flags are readable (using function code 01) and writable (using function code 05).

REG	DESCRIPTION	RANGE	P.-##
4000	Buzzer flag (0 or 1=ON)	0-1	--
4001	Test required (if operating for >1 year) (1=requires testing)	0=Okay 1=Test	--

## 12 REPLACEMENT PARTS AND ACCESSORIES

**NOTE:** All modules come ready to mount to the original mounting base provided.

### 12.1 Splash Guard

The splash guard is a protective covering that attaches to the front of the enclosure. CETCI recommends using a splash guard to protect the detector's sensor in wet environments or where spray-down of equipment is a common occurrence such as meat processing rooms, food and beverage facilities or chiller rooms.

Each splash guard comes with standard mounting hardware, instruction sheet and a mounting template. The unit can be used on existing installations. The clear poly carbonate housing allows for alarms to be seen through the front window. Slots along the side and bottom allow for gas to flow into and out of the sensor, while protecting the instruments from water damage.



front exterior view

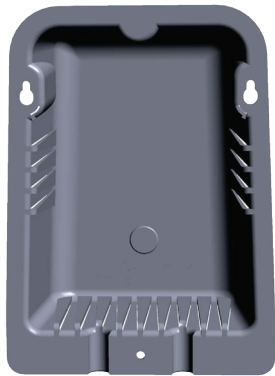

interior view

### 12.1.1 Splash Guard Mounting Template

The splash guard uses key-hole mounting slots designed for #6 pan head fasteners that are provided with the splash guard. Locate the two screws in the keyholes (as shown in the diagram below). Allow the screw heads to protrude approximately 1/8 inch (3 mm).

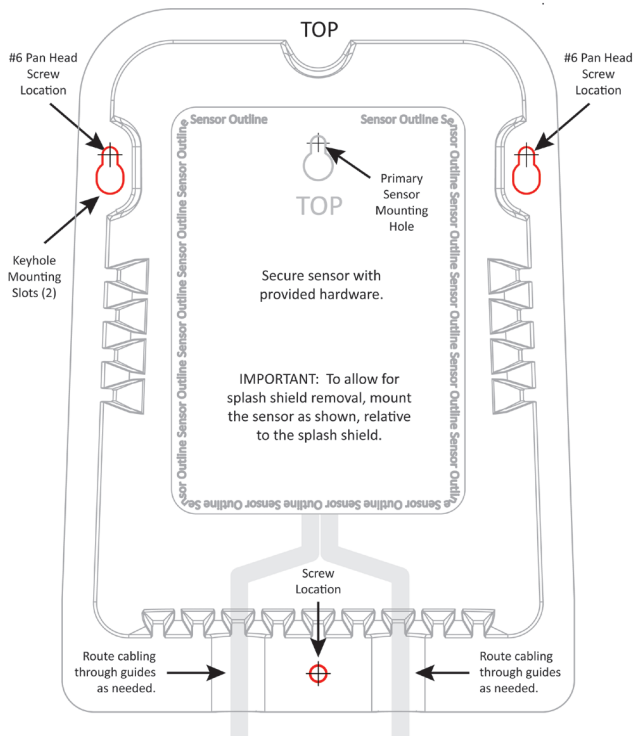

## 12.2 Metal Protective Guard

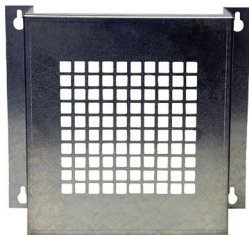

Part Code: SCS-8000-SPG

The metal protective guard is heavy duty metal protective grate to help protect against abrasive damage, theft and vandalism to the transmitters. This is an added preventative on top of the product enclosure and the splash guard (if installed).

It is made from 16-gauge galvanized steel and has  $\frac{1}{2}$ " (13 mm) square openings in the front to allow gas and air to flow through to the sensor. With only four slotted mounting holes, installation and removal for gas detector servicing is easy.

Enclosure	16 gauge galvanized steel
Weight	1.7 kg (3.8 lbs)
Size	10.0" W x 9.5" H x 4.8" D (254 mm W x 241 mm H x 121 mm D)

## 12.3 Calibration Kit



Part Code: CET-715A-CK1

Calibration kits and gases are available from the CETCI factory. Many gases are carried in inventory but not all. Check with any CETCI authorized distributor for availability of specific gas types. Gas cylinders cannot be shipped overseas.

## 13 TROUBLE SHOOTING

### 13.1 Fault Codes

To comply with the requirements of EN378 and the European F-GAS regulation, gas detectors must be tested annually. However, local regulations may specify the nature and frequency of this test.

The ART features sophisticated internal status monitoring and will indicate whether a fault condition exists, both on the front display (F.-XX, with XX being the fault number) and over the Modbus communications network.

There are two classes of fault conditions: critical and non-critical. In general, non-critical faults occur...

**...when environmental conditions exist that are outside the product's specified**

## operating range, or if an installation error has occurred (wrong wiring, for example).



The gas detector will typically continue to monitor its surroundings (except for fault F.-08), and may report inaccurate readings and false alarms.







Correcting non-critical faults is a matter of waiting for the environmental conditions to return to a more typical condition, correcting wiring mistakes, or in some cases, relocating the gas detector. For example, placing the gas detector near a forced air heater may cause temperature faults. The non-critical fault range is F.-01 to F.-08. Critical faults indicate...

## ... a functional problem that results in the gas detector no longer monitoring its surroundings for refrigerant.

The fault number is displayed and the power LED is turned off, indicating that the gas detector is offline. The critical fault range is F.-09 to F.-16. If any of these faults occur, first try to clear the faults by cycling power to the sensor. The easiest way to do this is by removing the sensor from the base and reattaching. If the fault returns after cycling power, the gas detector should be removed from service and replaced.

Additionally, the faults are stored as a hex code number and can be accessed in the Diagnostics menu P.-18. Refer to *Diagnostics Attributes P.-18* in Section 13.2 for additional information.

DESCRIPTION	FAULT CODE	HEX CODE	POSSIBLE CAUSES
Gas Detector Temperature Fault		0x0001	Gas Detector temperature reports > 55° C or < -35° C.
Gas Detector Temperature Rate of Change Fault		0x0002	Temperature rate of change exceeds ~1° C/min for more than 15 minutes.





RS485 RX Fault		0x0004	Message too long for receive buffer.
RS485 CRC Fault		0x0008	Transmission is corrupted (computed CRC doesn't match transmitted CRC).
Open Loop Fault		0x0010	Possible wiring, connection, and/or termination issue exists. When analog output type is 4 20ma and loop is open, use 18-24 AWG shielded twisted pair with 120 ohm characteristic impedance for Modbus connections.
Modbus Fault		0x0020	Modbus message was truncated or timed out early.
PPM Over-range Fault		0x0040	ppm exceeds 9,999. This may indicate a very large gross leak. If no leak is present, it indicates a gas detector error.
Input Voltage Fault		0x0080	Input supply power to the ART is out of range (i.e., $24V \pm 20\%$ ).  <b>IMPORTANT:</b> If this fault is active, the gas detector is offline and not monitoring. Correct the input supply voltage to restore normal operation.







Critical Faults		<p><b>Critical fault. Cycle power to the sensor and see if the fault clears. If not, the gas detector should be removed from service and replaced.</b></p>
-----------------	---	--

### 13.2 Diagnostic Attributes (P.-18)

Use this option to review the built-in diagnostic attributes. Access the parameter list (see Section 9 *Setting and Configuring the Parameters*) and select P.-18. Press the Enter button to access the diagnostics, and then use the UP or DOWN button to select each attribute. The following information is available.

ATTRIBUTE	DESCRIPTION
	<p>Displays the current fault condition code in hex format:            0000 = no faults are active            XXXX = HEX number            See Section 13.1 <i>Fault Codes</i> for the HEX format cross reference.</p>
	<p>Displays a hex format code that corresponds to any faults that occurred since the internal fault record was last erased. See Section 13.1 <i>Fault Codes</i> for the HEX format cross reference. The records may be erased by pressing the ENTER button.</p>
	<p>Displays the number of days that the ART has been in service. The value of this attribute rolls over after 9999.</p>
	<p>Displays the elapsed time (in days) from the last gas adjustment or test. This value is automatically reset to 0000 after completing a gas adjustment via Test Mode P.-17. (Note that the new adjustment is stored using the Enter button.) The value may be reset to 0000 by pressing the ENTER button.</p>

	Reserved
	Displays the sensor temperature in °C.
	Displays the sensor's approximate rate of temperature change per half minute interval (°C change over 30 seconds).
	Reserved

### 13.3 Resetting to Default Values

The gas detector may be reset to its default state, if needed, to aid in troubleshooting. All settings, including alarm setpoint, gas adjustments, selected gas curve, calibration data, Modbus address, etc. revert to specific default values after a reset. The broadband sensor option resets to gas group 1. Gas specific options are reset to the R134a gas curve.

**NOTE:** Calibrations on either gas-specific or broadband models are lost after a reset. This returns the gas detector to an uncalibrated condition. See Parameter P.-17 for information on how to recalibrate the gas detector.

Before performing this operation it is advisable to write down all the parameter settings, so they can be re-programmed.

#### Step 1:

Access diagnostics menu P.-18.

**Step 2:**

Press and hold both the UP and DOWN buttons for 5 seconds. This will cause the following to occur:

- All the LED segments will then light for 3 seconds
- The gas detector resets to the default settings
- The gas detector beeper sounds for 3 seconds.

**Step 3:**

After 3 seconds the user is returned to the Parameter List at parameter P.-18.

**Step 4:**

The gas detector may now be re-programmed for further troubleshooting if needed.



**Critical Environment Technologies Canada Inc.**

Unit 145, 7391 Vantage Way, Delta, BC, V4G 1M3, Canada

Toll Free: +1.877.940.8741

Tel: +1.604.940.8741

Fax: +1.604.940.8745

[www.critical-environment.com](http://www.critical-environment.com)

