

QUICK REFERENCE GUIDE

Loop Power Converter



- Analog output converter module
- Compatible with HMP60 and HMP110
- Converts one 0 ... 2.5 VDC voltage output to loop powered 4 ... 20 mA current output

GENERAL

The loop power converter is an open frame module that converts one 0 ... 2.5 VDC voltage output to a loop powered 4 ... 20 mA current output.

The instrument that is connected to the module must be powered by the 5 VDC supply voltage from the converter. The converted instrument must consume less than 2 mA.

NOTE When installing the module, provide an earth connection from the plated mounting hole.

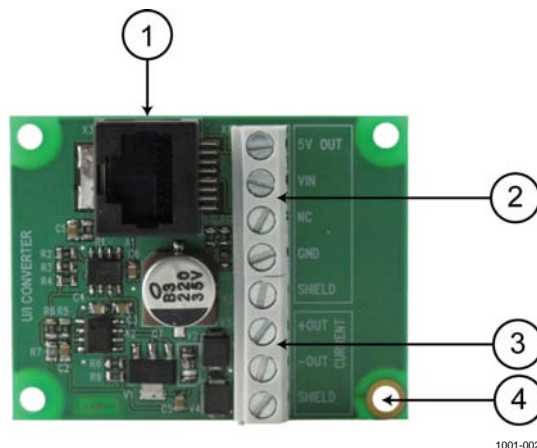

Figure 1 Loop Power Converter

- 1 = Factory test connector (DO NOT USE)
- 2 = Screw terminals for instrument connection

5V OUT: supply voltage to converted instrument
 VIN: input signal, 0 ... 2.5 VDC
 NC: not connected
 GND: ground
 SHIELD: cable shield (connect if available)

- 3 = Screw terminals for current output:

+OUT: current loop +
 -OUT: current loop -
 SHIELD: cable shield (connect if available)

- 4 = Plated mounting hole for earth connection

INSTALLATION EXAMPLE WITH HMP60

The loop power converter can be used with the HMP60 and HMP110 humidity and temperature probes. To use the loop power converter with these probes, make sure that:

- The probe is in the analog output mode
- The desired quantity must be on channel 1
- Channel 1 is scaled to 0 ... 2.5 V

NOTE Channel 2 of the HMP60/HMP110 is not converted by the loop power converter.

Make the connections as shown in Figure 2 below. The wire colours refer to the HMP60 and HMP110 compatible cables supplied by Vaisala.

After making the connections, power up the loop power converter and verify that the measurement is working.

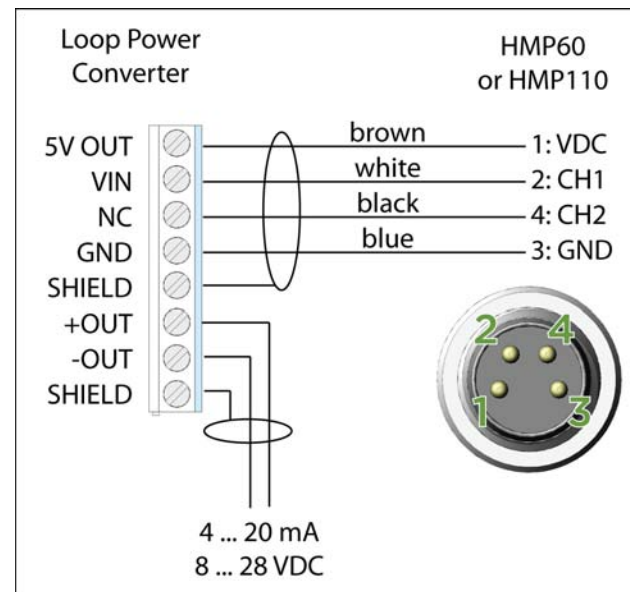

Figure 2 Wiring with HMP60 or HMP110



INSTALLATION WITH MOUNTING BRACKET

The loop power converter can be installed in a mounting bracket. The bracket has a metal backplate and a plastic lid, and it can be installed on a DIN rail. Note that the bracket does not provide IP rated protection.

The mounting bracket is delivered with a set of screws and attachment accessories for cables.

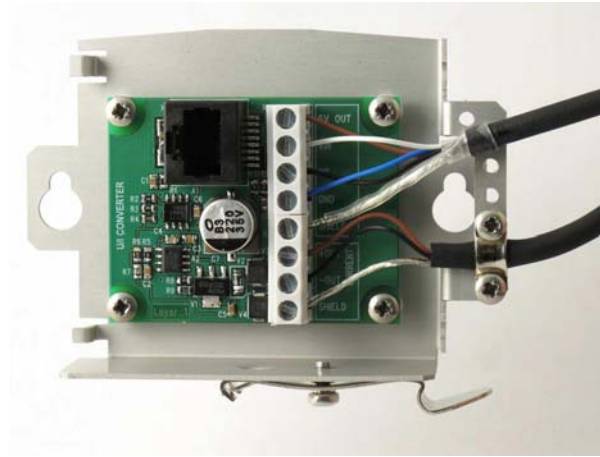

1001-003

Figure 3 Attaching the Module and Connecting the Wires

After installing the module on the bracket, attach the plastic lid over the bracket and tighten the two screws.



1001-004

Figure 4 Module Installed in Mounting Bracket

TECHNICAL DATA

Property	Description / Value
Input signal	0 ... 2.5 VDC
Output signal	Two wire 4 ... 20 mA (loop powered)
External loop load	8 ... 28 VDC ($R_L = 0$ ohms) 18 ... 28 VDC ($R_L = 500$ ohms)
Conversion accuracy	1% of scale
Operating voltage	8 ... 28 VDC
Power supply to converted instrument	5 VDC < 2 mA
Wire size for screw terminals	0.5 ... 1.5 mm ²
Operating temperature range	+10 ... +40 °C (+50 ... +104 °F)
Storage temperature range	-40 ... +60 °C (-50 ... +140 °F)
Electromagnetic compatibility	EN 61326-1:2006 Electrical equipment for measurement, control and laboratory use - EMC requirements - Basic immunity test requirements. EN 55022:2006 + Am 1: 2007 Information technology equipment - Radio disturbance characteristics - Limits and methods of measurement. Class B.

DIMENSIONS

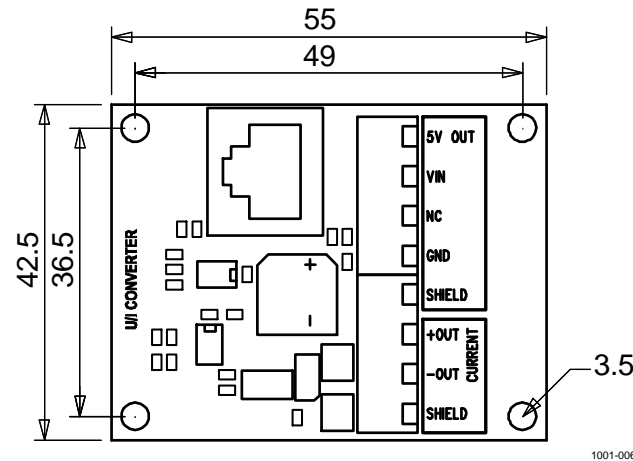

1001-006

Figure 5 Loop Power Converter Dimensions (in mm)

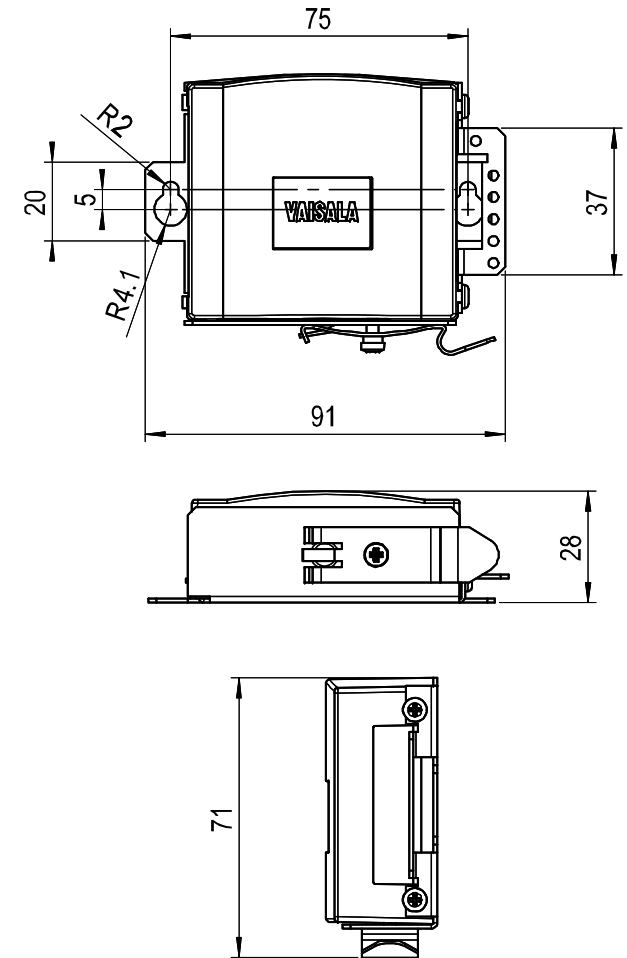

0911-106

Figure 6 Mounting Bracket Dimensions (in mm)