

User Guide

Vaisala Wi-Fi Data Logger

HMT140

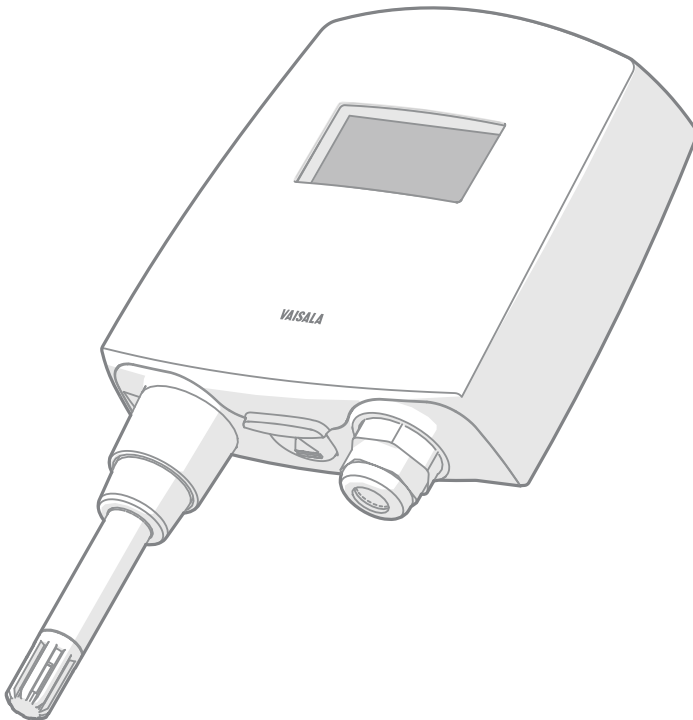

VAISALA

PUBLISHED BY

Vaisala Oyj
Vanha Nurmijärventie 21, FI-01670 Vantaa, Finland
P.O. Box 26, FI-00421 Helsinki, Finland
+358 9 8949 1

Visit our Internet pages at www.vaisala.com.

© Vaisala Oyj 2019

No part of this document may be reproduced, published or publicly displayed in any form or by any means, electronic or mechanical (including photocopying), nor may its contents be modified, translated, adapted, sold or disclosed to a third party without prior written permission of the copyright holder. Translated documents and translated portions of multilingual documents are based on the original English versions. In ambiguous cases, the English versions are applicable, not the translations.

The contents of this document are subject to change without prior notice.

Local rules and regulations may vary and they shall take precedence over the information contained in this document. Vaisala makes no representations on this document's compliance with the local rules and regulations applicable at any given time, and hereby disclaims any and all responsibilities related thereto.

This document does not create any legally binding obligations for Vaisala towards customers or end

users. All legally binding obligations and agreements are included exclusively in the applicable supply contract or the General Conditions of Sale and General Conditions of Service of Vaisala.

This product contains software developed by Vaisala or third parties. Use of the software is governed by license terms and conditions included in the applicable supply contract or, in the absence of separate license terms and conditions, by the General License Conditions of Vaisala Group.

This product may contain open source software (OSS) components. In the event this product contains OSS components, then such OSS is governed by the terms and conditions of the applicable OSS licenses, and you are bound by the terms and conditions of such licenses in connection with your use and distribution of the OSS in this product. Applicable OSS licenses are included in the product itself or provided to you on any other applicable media, depending on each individual product and the product items delivered to you.

Table of Contents

1.	About This Document	7
1.1	Version Information.....	7
1.2	Related Manuals.....	7
1.3	Documentation Conventions.....	7
1.4	Trademarks.....	8
2.	Product Overview	9
2.1	Overview of HMT140 Features.....	9
2.1.1	Data Management.....	9
2.1.2	Models.....	9
2.1.3	Options and Accessories.....	10
2.1.4	Fixed or Remote Probe.....	10
2.1.5	Interchangeable Probe.....	10
2.1.6	Optional Display.....	11
2.2	HMT140 Components.....	12
2.2.1	Installation Kit.....	12
2.2.2	HMT140 Utility and Configuration Cable.....	13
2.2.3	Connections and Wiring.....	14
2.3	Safety.....	16
2.3.1	ESD Protection.....	17
2.4	Regulatory Compliances.....	17
2.4.1	FCC Compliance Statement.....	18
2.4.2	ISED Compliance Statement.....	18
3.	Installation	19
3.1	Mounting.....	19
3.1.1	Opening Data Logger Cover.....	19
3.1.2	Wall Mounting.....	20
3.1.3	Duct Installation.....	22
3.1.4	Probe Assembly with Duct Installation Kit.....	22
3.2	Optional Mounting Accessories.....	24
3.2.1	Probe Mounting Flange.....	24
3.2.2	Probe Mounting Clamp.....	24
4.	Set Up and Operation	25
4.1	Connect and Configure.....	25
4.1.1	Installing HMT140 Utility Software.....	25
4.1.2	Setting up HMT140 Hardware.....	25
4.1.3	Configuring the HMT140 to Your Network.....	26
4.1.4	Setup Consideration.....	28
4.2	Custom Settings.....	28
4.2.1	Modify Transmission Settings.....	28
4.2.2	Modify HMT140 Description.....	31
4.2.3	Check Transmission Status.....	31

- 4.3 HMT140 Function Modes..... 33
 - 4.3.1 Operating Modes..... 33
 - 4.3.2 Transmission of Data..... 34
 - 4.3.3 Transmit Attempts..... 34
 - 4.3.4 Alarm-triggered Transmission..... 34
- 4.4 Additional Settings..... 35
 - 4.4.1 Change Input/Output Scale..... 35
 - 4.4.2 Save and Recall Settings..... 36
 - 4.4.3 Delete Saved Settings..... 36
 - 4.4.4 Restart the HMT140..... 36
 - 4.4.5 Get General Information..... 36
- 4.5 Battery Usage..... 36
 - 4.5.1 Viewing Battery Life Remaining..... 36
 - 4.5.2 Units and Temperature..... 37
 - 4.5.3 Connection Performance..... 38
- 4.6 Advanced Options..... 39
 - 4.6.1 Passwords..... 40
 - 4.6.2 Set Up a New Channel..... 41
 - 4.6.3 Find Additional Networks..... 42
 - 4.6.4 Test Network Connectivity..... 43
- 4.7 Additional Program Parameters..... 43
- 5. Maintenance..... 45**
 - 5.1 Improving Sensor Response Time..... 45
 - 5.2 Removing and Fastening Probes..... 45
 - 5.2.1 Fixed Probe Model..... 45
 - 5.2.2 Remote Probe Model..... 46
 - 5.3 Calibration and Adjustment..... 47
 - 5.4 Battery Replacement..... 48
- 6. Troubleshooting..... 49**
 - 6.1 HMT140 Operation Mode..... 49
 - 6.2 Signal Strength..... 49
 - 6.3 Indicator Lights..... 49
 - 6.4 Access Points..... 49
 - 6.5 Transmit Cycle..... 50
 - 6.6 Frequently Asked Questions..... 50
- 7. Technical Data..... 54**
 - 7.1 HMT140 Dimensions (Fixed Probe)..... 54
 - 7.2 HMT140 Dimensions (Remote Probe)..... 55
 - 7.3 HMT140 Product Specifications..... 56
- Index..... 63**
- Warranty..... 65**
- Technical Support..... 65**

Recycling..... 65

List of Figures

Figure 1	HMT140 Features.....	12
Figure 2	HMT140 Components Diagram.....	14
Figure 3	RTD Wiring Diagram.....	15
Figure 4	RTD and Boolean Wiring Diagram.....	15
Figure 5	Boolean Wiring Diagram.....	15
Figure 6	Voltage Wiring Diagram.....	16
Figure 7	Current Wiring Diagram.....	16
Figure 8	Opening Data Logger Cover.....	19
Figure 9	Mounting Diagram.....	21
Figure 10	Probe Installation with Duct Installation Kit.....	22
Figure 11	Dimensions of HMP110 Probe with Duct Installation Kit.....	23
Figure 12	Optional Probe Mounting Flange.....	24
Figure 13	Optional Probe Mounting Clamp.....	24
Figure 14	Fixed Probe Model.....	46
Figure 15	Remote Probe Model.....	47
Figure 16	HMT140 Fixed Probe Dimensions in mm (in).....	54
Figure 17	HMT140 Remote Probe Dimensions in mm (in).....	55

List of Tables

Table 1 Document Versions (English).....7
Table 2 Related Manuals.....7
Table 3 Connect Time Components38
Table 4 HUMICAP® Humidity and Temperature Probe HMP110..... 56
Table 5 Temperature Probes.....56
Table 6 Analog Inputs.....57
Table 7 Measurement Variants..... 57
Table 8 Operating Environment.....58
Table 9 General Specifications.....58
Table 10 Mechanical Specifications..... 58
Table 11 Wireless..... 59
Table 12 Standards.....59
Table 13 Spare Parts and Accessories..... 60

1. About This Document

1.1 Version Information

This document provides information for installing, operating, and maintaining the Vaisala Wi-Fi Data Logger HMT140. It also details the operation of the Vaisala HMT140 Utility software.

Table 1 Document Versions (English)

Document Code	Date	Description
M211488EN-G	April 2019	New document template. Added chapters Regional Versions (page 10) , FCC Compliance Statement (page 18) , and ISED Compliance Statement (page 18) . Updated power supply specifications and chapter HMT140 Product Specifications (page 56) .

1.2 Related Manuals

Table 2 Related Manuals

Document Code	Name
M211484EN	<i>Vaisala Wi-Fi Data Logger HMT140 Quick Guide</i>
M211975EN	<i>Vaisala viewLinc Enterprise Server Version 5.0 User Guide</i>

1.3 Documentation Conventions



WARNING! Warning alerts you to a serious hazard. If you do not read and follow instructions carefully at this point, there is a risk of injury or even death.



CAUTION! Caution warns you of a potential hazard. If you do not read and follow instructions carefully at this point, the product could be damaged or important data could be lost.



Note highlights important information on using the product.



Tip gives information for using the product more efficiently.



Lists tools needed to perform the task.



Indicates that you need to take some notes during the task.

1.4 Trademarks

Vaisala® and HUMICAP® are registered trademarks of Vaisala Oyj.

All other product or company names that may be mentioned in this publication are trade names, trademarks, or registered trademarks of their respective owners.

2. Product Overview

2.1 Overview of HMT140 Features

The Vaisala Wi-Fi Data Logger HMT140 measures relative humidity and temperature using the connected probe and analog signals – RTD, Voltage, Current Loops and Boolean Contacts. The HMT140 comes with or without an optional LCD display.

The HMT140 supports several different signal measurements (channels), which are monitored in Vaisala viewLinc Enterprise Server software:

- Relative Humidity (RH)
- Temperature (T)
- Switch Contact
- Voltage and Current

Channel types are set at the factory during the time of order. Other wireless parameters can be changed at a later date using an HMT140 Configuration Cable and Vaisala HMT140 Utility software.

More Information

- [Options and Accessories \(page 10\)](#)

2.1.1 Data Management

An HMT140 can store several thousands of records before needing to overwrite data. In the event of a communication problem, the HMT140 will continue to log and store data until it has collected 3060 records per channel and then it will begin overwriting data.

For example, if an HMT140 is configured with a 5-minute sample rate, it will continue to log data for approximately 10 days before overwriting data.

2.1.2 Models

The following HMT140 models and options are available:

- HMT141: Vaisala HUMICAP® Humidity and Temperature Probe (RH/T)
- HMT143: Dual RTD Temperature Inputs w/5 m Probes (-90 to +90 °C (-130 to +194 °F))
- HMT144: Voltage Inputs (0 ... 5 VDC)
- HMT145: Voltage inputs (0 ... 10 VDC)
- HMT146: Current Inputs (0 ... 20 mA)
- HMT147: Boolean Inputs
- HMT148: RTD Temperature Input w/5 m Probe and Boolean Input
- HMT14C: RTD Inputs (customer-supplied Probe)
- HMT14D: RTD and Current Input
- HMT14E: RTD and Voltage Input (0 ... 5 VDC)
- HMT14F: RTD and Voltage Input (0 ... 10VDC)

2.1.2.1 Regional Versions

There are 2 regional versions of each HMT140 model, with different applicable standards and regulations. The versions are distinguished by the letters **A** (for EU countries) and **N** (for non-EU countries) on the HMT140 Order Form.

For more information, see [Table 12 \(page 59\)](#).

2.1.3 Options and Accessories

- Humidity and temperature probe HMP110
- Humidity and temperature replacement probe HMP110R (Requires a separate order form. For more information, contact Vaisala.)
- Humidity sensor HUMICAP180R
- HMP110 Probe mounting flange 226061
- HMP110 Probe mounting clamps, 10 pcs 226067
- HMP110 Probe cable 3 m (9.8 ft) HMT120Z300
- HMP110 Probe cable 5 m (16.4 ft) HMT120Z500
- HMP110 Probe cable 10 m (32.8 ft) HMT120Z1000
- Duct installation kit 215619
- Probe mounting flange 226061
- Boolean Switch Kit with Door Contact 236319
- Thermal Dampener Blocks 236310SP
- Recommended battery: Xeno XL-060F
 - Form Factor: AA
 - Chemistry: Lithium-Thionyl chloride (Li-SOCl₂)
 - Nominal Voltage: 3.6V
 - Nominal Capacity: 2400mAh
 - Pulse Current Capability: 120mA
 - Operating Temperature Range: -40 °C... +60 °C (-40 °F... +140 °F)
 - Voltage @ 2mA & -20 °C (-4 °F): 2.6V
 - Voltage @ 2mA & +60 °C (+140 °F): 2.6V
- HMP110 sensor protection:
 - Plastic grid filter DRW010522SP
 - Plastic grid with membrane filter DRW010525
 - Stainless steel sintered filter HM46670SP

2.1.4 Fixed or Remote Probe

The HMT140 is available either with a fixed probe directly attached to the housing or a remote probe with different cable lengths (3/5/10 m (9.8/16.4/32.8 ft)). Extension cables can be easily cascaded in order to obtain longer reach, to a maximum length of 10 m (32.8 ft).

2.1.5 Interchangeable Probe

The HMP110 HUMICAP® relative humidity probe used in the HMT140 is fully interchangeable. You can easily remove the probe and replace it with a new one without having to adjust the HMT140. You have the following options when purchasing a new probe from Vaisala:

- Order a new probe and keep your current one.

- Order a new probe and return the old one to Vaisala (replacement probe).



Only probes that have a compatible digital output (VDIGI mode) can be used with the HMT140. Compatible probes have the letter "V" as the first letter in their order code. The order code is written on the probe.

2.1.6 Optional Display

The HMT140 is also available with an optional graphical 128x64 pixel resolution LCD display. The display shows the measurement results of selected parameters in selected units (defined at the time of ordering). The parameters are displayed simultaneously as two separate rows on the display.

2.2 HMT140 Components

The following figure illustrates the main features of the HMT140. On the left is a remote probe model without display, and on the right is a fixed probe model with the optional display. The numbers and arrows indicate the main components of the HMT140 models.

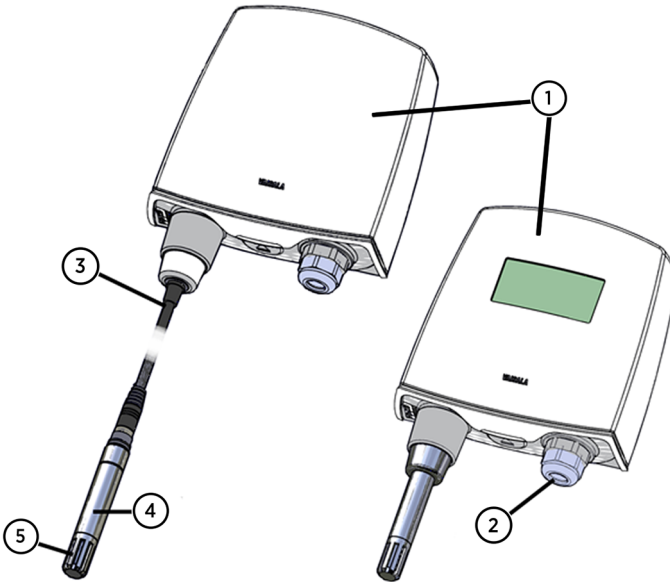

Figure 1 HMT140 Features

- 1 HMT140 enclosure
- 2 Cable bushing: cable gland
- 3 Probe cable
- 4 HMP110 probe
- 5 Plastic grid filter

2.2.1 Installation Kit

The HMT140 is typically installed mounted on the wall with up to four screws (not included).

For duct mounting, Duct Installation Kits are available as accessories.

To help you position the screws correctly, use the Drilling Template, available inside the back cover of the *HMT140 Quick Guide*.

More Information

- [Options and Accessories \(page 10\)](#)
- [Wall Mounting \(page 20\)](#)

2.2.2 HMT140 Utility and Configuration Cable

To connect an HMT140 to your network, install the HMT140 Utility software and connect the HMT140 to your PC with the HMT140 Configuration Cable (software and cable shipped with viewLinc).

More Information

- [Configuring the HMT140 to Your Network \(page 26\)](#)

2.2.3 Connections and Wiring

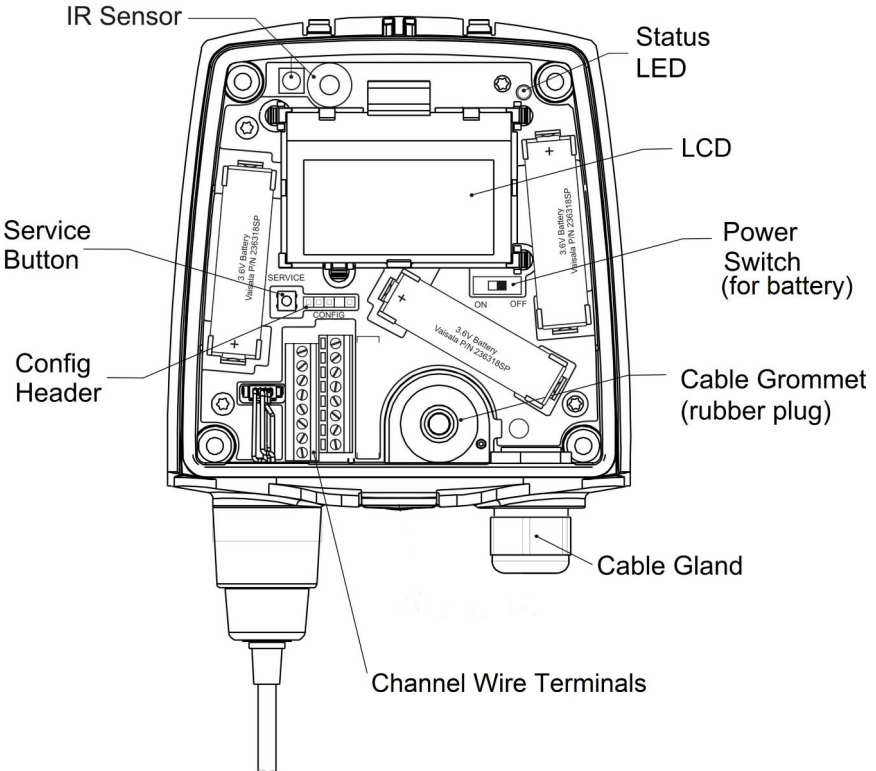

Figure 2 HMT140 Components Diagram

Channel 1: RTD

Channel 2: RTD

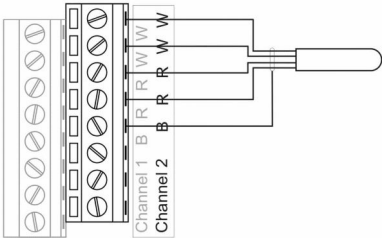
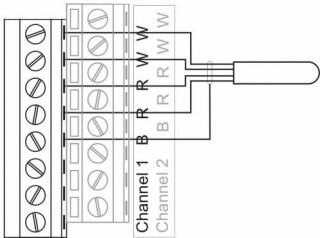

Figure 3 RTD Wiring Diagram

Channel 1: RTD

Channel 2: Boolean
(Magnetic Switch)

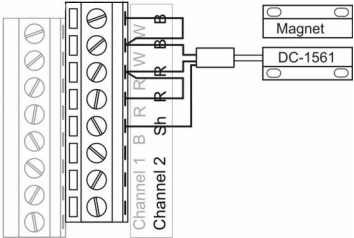
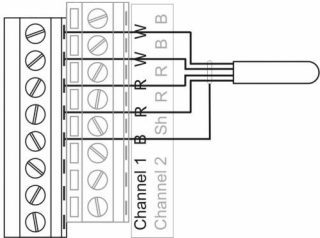

Figure 4 RTD and Boolean Wiring Diagram

Channel 1: Boolean
(Magnetic Switch)

Channel 2: Boolean
(Magnetic Switch)

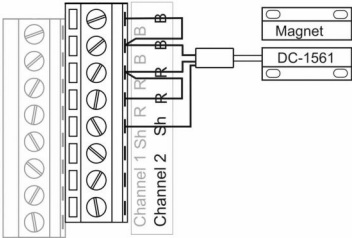
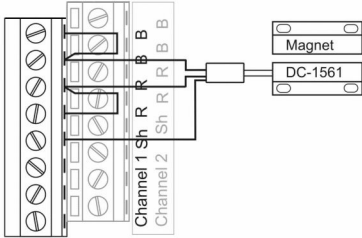

Figure 5 Boolean Wiring Diagram

Channel 1: DC Voltage

Channel 2: DC Voltage

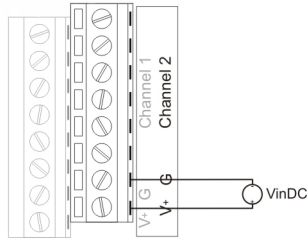
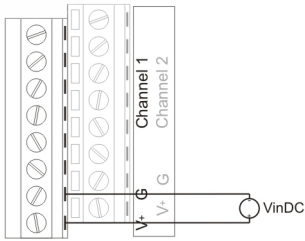

Figure 6 Voltage Wiring Diagram

Channel 1: Current Loop 4-20mA

Channel 2: Current Loop 4-20mA

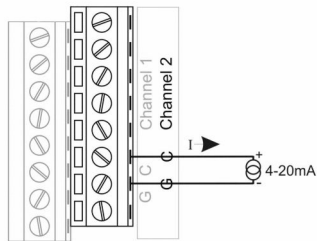
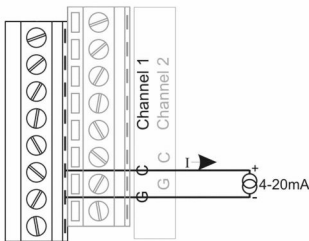

Figure 7 Current Wiring Diagram

2.3 Safety

This product has been tested for safety. Note the following precautions:



WARNING! Remove batteries before shipping.



CAUTION! Do not modify the unit or use it in ways not described in the documentation. Improper modification may lead to safety hazards, equipment damage, failure to perform according to specification, or decreased equipment lifetime.



WARNING! If the equipment is used in a manner not specified by Vaisala, the protection provided by the equipment may be impaired.



CAUTION! This device requires a separation distance of at least 20 cm. This distance must be maintained between the user and the device when the device is operating.



CAUTION! Cet appareil nécessite une distance de séparation d'au moins 20 cm. Cette distance doit être maintenue entre l'utilisateur et l'appareil lorsque l'appareil est en fonctionnement.

2.3.1 ESD Protection

Electrostatic Discharge (ESD) can damage electronic circuits. Vaisala products are adequately protected against ESD for their intended use. However, it is possible to damage the product by delivering electrostatic discharges when touching, removing, or inserting any objects in the equipment housing.

To avoid delivering high static voltages to the product, handle ESD-sensitive components on a properly grounded and protected ESD workbench or by grounding yourself to the equipment chassis with a wrist strap and a resistive connection cord.

2.4 Regulatory Compliances

This product complies with the following standards:

- EN 61326-1B, EN 301 489-1 ¹⁾
- EN 300 328 V2.1.1

This product complies with the following safety standard:

- EN 61010-1

The HMT140 contains a radio module with the following module approvals:

- FCC ID: U30-G2M5477
- IC ID: 8169A-G2M5477
- NCC ID: CCAF11LP0240T6
-  201-125765 当該機器には電波法に基づく、技術基準適合証明等を受けた特定無線設備を装着している。

1) EN 61326-1B and EN 301 489-1 apply only to the EU specific versions of HMT140 loggers with CE marking.

2.4.1 FCC Compliance Statement

This equipment has been tested and found to comply with the limits for a Class B digital device, pursuant to Part 15 of the FCC rules. These limits are designed to provide reasonable protection against harmful interference in a residential installation. This equipment generates, uses and can radiate radio frequency energy and, if not installed and used in accordance with the instructions, may cause harmful interference to radio communications. However, there is no guarantee that the interference will not occur in a particular installation. If this equipment does cause harmful interference to radio or television reception, which can be determined by turning the equipment off and on, the user is encouraged to try to correct the interference by one or more of the following measures:

- Reorient or relocate the receiving antenna.
- Increase the separation between the equipment and receiver.
- Connect the equipment into an outlet on a circuit different from that of the receiver.
- Consult the dealer or an experienced radio/TV technician for help.



WARNING! This device complies with part 15 of the FCC Rules. Operation is subject to the following two conditions: (1) This device may not cause harmful interference, and (2) this device must accept any interference received, including interference that may cause undesired operation.



WARNING! Changes or modifications to this equipment not expressly approved by the party responsible for compliance could void the user's authority to operate the equipment.

2.4.2 ISED Compliance Statement

This device complies with Industry Canada licence-exempt RSS standard(s). Operation is subject to the following two conditions:

1. This device may not cause interference; and
2. This device must accept any interference, including interference that may cause undesired operation of the device.

This device has a whip antenna with a gain of 2 dBi.

Le présent appareil est conforme aux CNR d'Industrie Canada applicables aux appareils radio exempts de licence. L'exploitation est autorisée aux deux conditions suivantes:

1. l'appareil ne doit pas produire de brouillage, et
2. l'utilisateur de l'appareil doit accepter tout brouillage radioélectrique subi, même si le brouillage est susceptible d'en compromettre le fonctionnement.

Le présent appareil dispose d'une antenne fouet avec un gain de 2 dBi.

3. Installation

3.1 Mounting

Depending on your installation requirements, you may wish to complete the network configuration and setup prior to mounting. Note that you can complete the configuration and setup procedures after mounting with a portable PC.



To connect the HMT140 to your network and view HMT140 data using viewLinc, you require HMT140 Utility software and an HMT140 Configuration Cable (shipped with viewLinc).

3.1.1 Opening Data Logger Cover

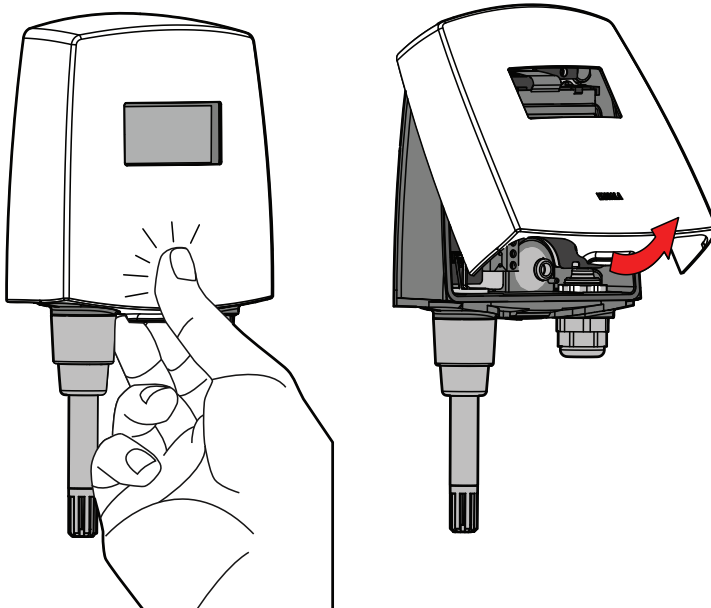

Figure 8 Opening Data Logger Cover

- ▶ 1. If the device is not mounted already, hold it against a flat surface.
- 2. Push on the cover with your thumb, and pull the bottom part of the cover towards yourself.

3.1.2 Wall Mounting

Before mounting an HMT140 device, consider the environment. It is recommended that wireless devices be mounted in an area with a minimum of wireless interference.

- If you plan to install a device without an LCD in a dark or low-light area, a high-traffic area, or an area with a solid object situated within 10 cm (3.9 in) of the front of the device, you may want to turn off the proximity sensor to avoid triggering unnecessary transmissions (see [Modify Transmission Settings \(page 28\)](#)).
- To ensure consistent communications and data transfer to Vaisala viewLinc, limit interference from solid structures or wireless/microwave radiation. For additional guidance, please contact Vaisala.



If mounting against a metal surface, be sure to keep a minimum of 2 mm (0.08 in) between the metal and the back of the HMT140 to ensure an uninterrupted radio signal.

- ▶ 1. Open the HMT140 cover.
2. Make sure that the HMT140 is correctly aligned and attach it directly to the wall with up to four screws (not included in the package).
Select the size and type of the fastening screws according to the wall material (for example, wood or stone). The diameter of the fastening screws is typically between 3.5 and 4 mm (0.14 and 0.16 in). Refer to the Drilling Template in the *HMT140 Quick Guide*.

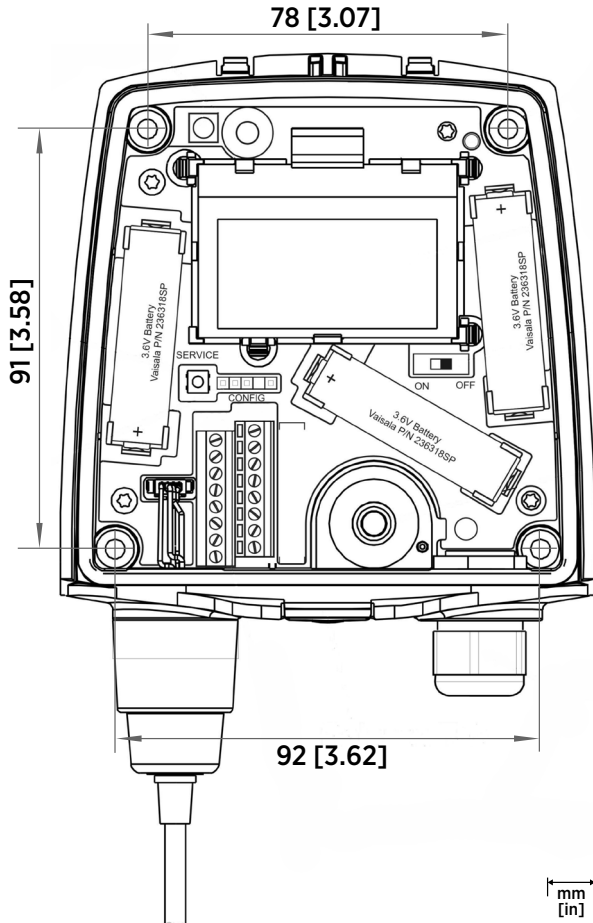

Figure 9 Mounting Diagram



Vaisala strongly recommends you to use all four screws; however, the HMT140 enclosure fastening holes are initially covered with a thin plastic membrane, so less than four screws could also be used without sacrificing the ingress protection (IP) class of the enclosure.

3.1.3 Duct Installation

The duct installation kit includes a plastic pipe with a flange (Vaisala order code: 215619). To install the HMP110 probe with the duct installation kit, drill a hole into the duct wall, assemble the probe to the duct installation kit, slide the probe head through the hole, and attach the flange to the duct wall with four screws.

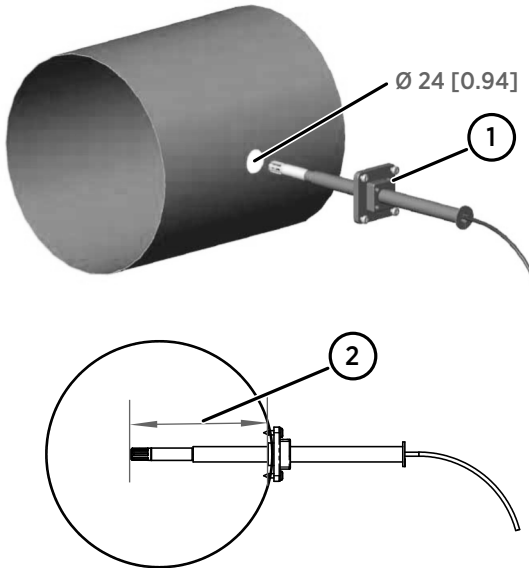
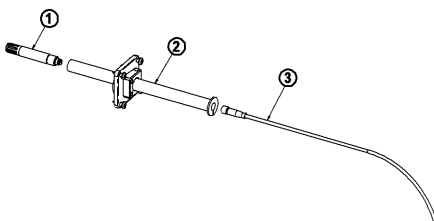

Figure 10 Probe Installation with Duct Installation Kit

- 1 Tension screw
- 2 Installation depth. Adjust the depth and lock in place with the tension screw.

3.1.4 Probe Assembly with Duct Installation Kit



- 1 Probe (HMP110)
- 2 Duct installation kit
- 3 Probe cable

1. Pass the probe cable through the plastic pipe of the duct installation kit.
2. Connect the probe cable to the HMP110.

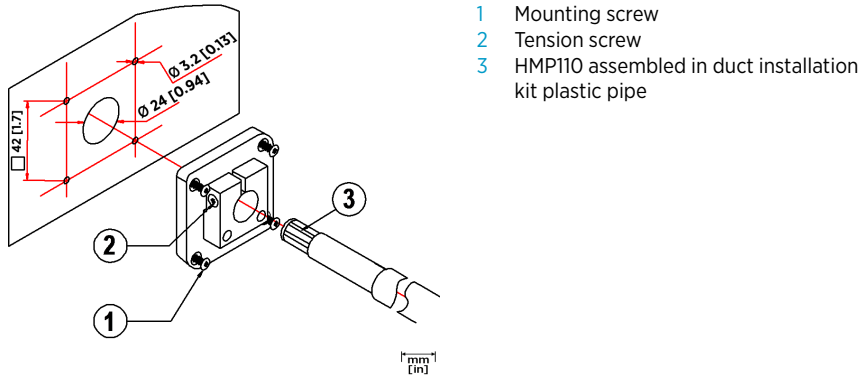

To attach the probe assembly to the duct:

1. Drill the holes for the duct installation kit as follows:
 - Use a 24-mm (0.9-in) drill bit to drill a hole in the wall.
 - Use a 3.2-mm (0.1-in) drill bit to make 4 holes for the installation screws (four ST4.2×16-C-Z DIN 7981 screws). The holes should be arranged in a square around the 24-mm (0.9-in) hole, at a distance of 42 mm (2 in) from each other.
2. Mount the probe holder using the screws.
3. Adjust the depth of the plastic pipe and tighten the screw to lock the probe in place.

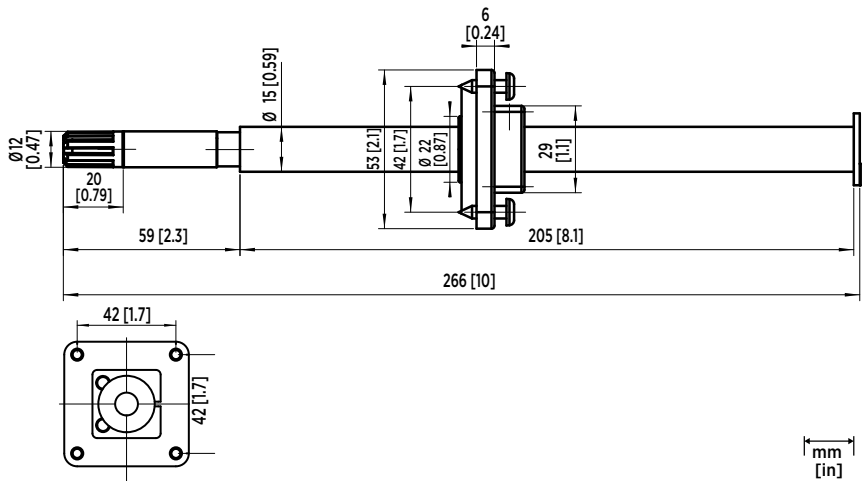

Figure 11 Dimensions of HMP110 Probe with Duct Installation Kit

3.2 Optional Mounting Accessories

3.2.1 Probe Mounting Flange

The probe mounting flange (Vaisala order code: 226061) is a general purpose mounting flange for 12 mm (0.5 in) diameter probes. It can be used to hold the HMP110 probe in a through-wall installation.



The silicone plug that is delivered with the flange is not suitable for use with the probe cable of the HMT140.

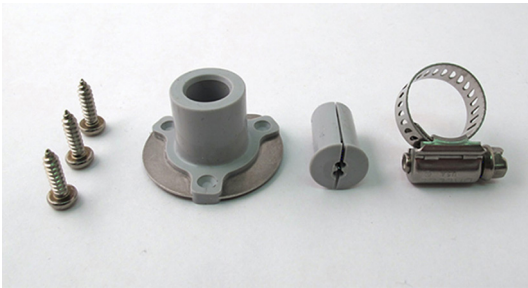

Figure 12 Optional Probe Mounting Flange

3.2.2 Probe Mounting Clamp

The optional mounting clamp (Vaisala order code: 226067) makes it easy to install the probe on the wall of the measurement environment. The probe can be detached for calibration simply by loosening the lower screw.

Installing the entire probe in the measurement environment prevents heat conduction to the sensor, and is the recommended installation method.

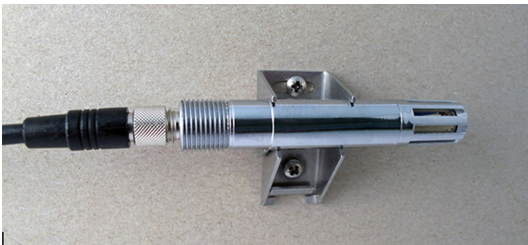

Figure 13 Optional Probe Mounting Clamp

4. Set Up and Operation

4.1 Connect and Configure

The HMT140 Configuration Cable allows you to connect an HMT140 to your PC. You can then configure the HMT140 with your network settings using the HMT140 Utility software (software and cable shipped with viewLinc).

4.1.1 Installing HMT140 Utility Software

The HMT140 Utility software configures and reads the settings in the HMT140 that use 802.11b and 802.11g wireless networks. The address of the destination host, the wireless network parameters, transmit period, and other important network functions of the HMT140 are specified using the HMT140 Utility. The HMT140 Utility also provides you with access to tools for diagnosing connection problems.

Before you configure the HMT140, install the HMT140 Utility software on a PC. The HMT140 Utility is compatible with Windows 10 (64-bit), Windows 8.1 (64-bit), Windows 7 (32-bit and 64-bit), Windows XP (32-bit), Windows Server 2008, and Windows Server 2012.

To install the HMT140 Utility software:

- ▶ 1. Disconnect the HMT140 Configuration Cable if it is already connected to your PC.
- 2. Insert the CD that came with the HMT140 Configuration Cable, or download the software from www.vaisala.com/hmt140.
- 3. Run the HMT140 Utility installation program (HMT140UtilitySetup.exe).
- 4. Accept the license agreement terms, then click **Next** to accept the installation default settings. The installation of the driver may take several minutes.
- 5. After the software is installed, connect the HMT140 Configuration Cable to a USB port on your PC to complete the installation setup.
- 6. When the installation is complete, disconnect the cable from your PC. You are now ready to set up and configure your device.

If you wish to remove the Vaisala HMT140 Utility software at a later date, use the uninstall function in the Windows **Control Panel**.

4.1.2 Setting up HMT140 Hardware

Once the HMT140 Utility software is successfully installed, you can set up your data monitoring device.

To set up the HMT140 for the first time:

- ▶ 1. Make sure the HMT140 Configuration Cable is disconnected from your PC.
- 2. Open the HMT140 cover.
- 3. Make sure the power switch on the device is in the OFF position.

4. Install three 3.6V lithium batteries. For the recommended battery type, see [Options and Accessories \(page 10\)](#).
5. Turn the power switch on the device to the ON position, and wait for the setup process to complete (five seconds). LED light turns on, then off.

4.1.3 Configuring the HMT140 to Your Network

After you install the HMT140 Utility and set up the HMT140, use the Configuration Cable and HMT140 Utility software to connect and configure the HMT140 to your network.



To avoid depleting the battery power too quickly, make sure that your network is on-line and available before configuring your device.

The following steps provide you with standard network settings. To set specific settings depending on your network configuration, see [Custom Settings \(page 28\)](#).



Follow the steps carefully. Do not connect the Configuration Cable to the HMT140 configuration port unless the Configuration Cable is connected to a computer USB port, the batteries are installed, and the power switch is in the ON position.

To configure the HMT140 for your network with standard settings:

- ▶ 1. Make sure that the HMT140 cover is open and the correct batteries are installed.
2. Turn on the HMT140 and wait five seconds to make sure the startup process completes.
3. Plug the USB connector on the HMT140 Configuration Cable to the computer, if it is not already connected.
4. From the **Start** menu, open the HMT140 Utility.
5. Connect the end of the HMT140 Configuration Cable labeled **USB Wi-Fi Programmer** to the 4-pin HMT140 CONFIG header.
6. On the HMT140 Utility **Setup** tab, click **Retrieve** to identify the HMT140. The bottom left status bar will initially read **Looking for sensor or USB programmer**, then, once the HMT140 is identified, the status bar will read **Found USB Programmer**.

7. Click **Retrieve** again to force retrieval of current settings. The connected type is identified in the upper right corner of the **Setup** tab window.

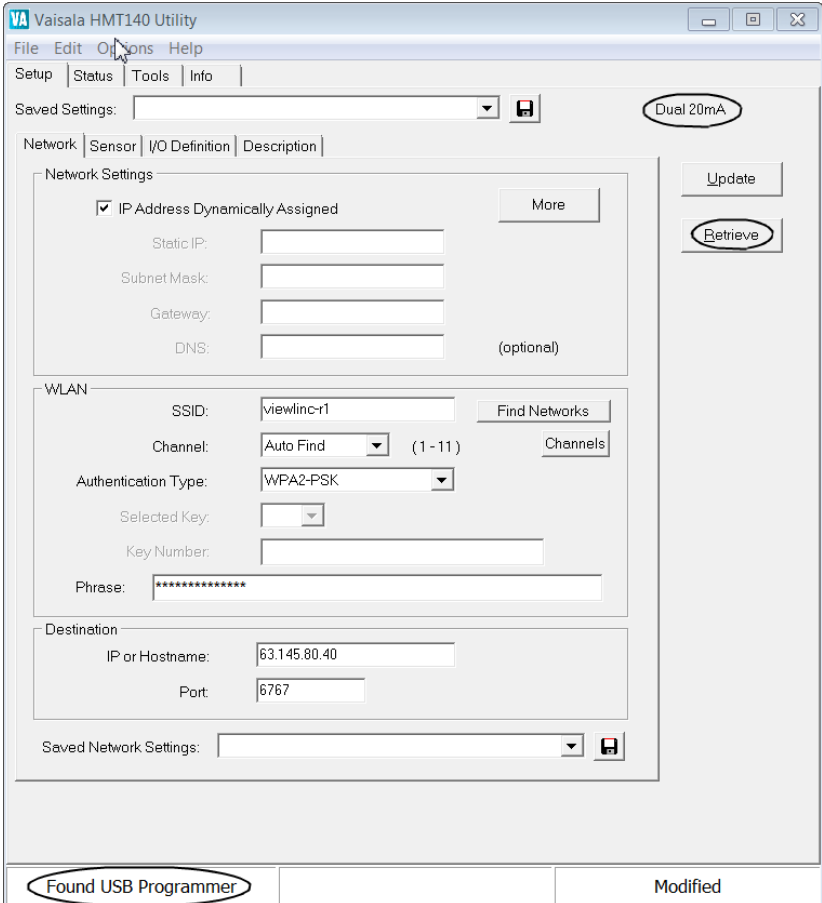

The status bar is located at the bottom of the HMT140 Utility window. It contains the following panels:

- **Left panel:** Displays the Configuration Cable status: **Found USB Programmer** or **Looking for USB Programmer**.
 - **Middle panel:** Displays progress messages of the different actions: **Update**, **Retrieve**, **Status**, and **Info**.
 - **Right panel:** Displays a message when the parameters on the **Setup** page have been modified and require saving.
8. If the IP address is static, uncheck the **IP Address Dynamically Assigned** option and enter the network parameters. Otherwise leave this option checked.
For additional IP address settings information see, [Check Transmission Status \(page 31\)](#).

9. Enter the parameters for the WLAN (wireless LAN router settings).
10. Enter the Destination IP address/name and port number of the host (viewLinc server settings).



If you do not know the information required, request these parameters from your network administrator.

11. Click the **Sensor** tab and select a **Transmit Period Time** and number of **Tries**, or accept the default settings.
12. Click **Update**. The HMT140 Utility will configure the HMT140.
13. Select the **Status** tab to check that the settings appear as configured. Click **Get** if the settings do not appear automatically.
14. Disconnect the HMT140 Configuration Cable from the HMT140 and wait for eight seconds.
15. Press the **SERVICE** button on the HMT140.
Optional: Enter a name for the saved settings on the **Setup** tab in the **Saved Settings** field, and click the disk icon to save.
To configure custom settings for the HMT140, see [Custom Settings \(page 28\)](#).

4.1.4 Setup Consideration

If DHCP or DNS is being used, it is best to use local DHCP and DNS servers rather than a DNS server on the internet. The local servers will give better response times compared to the remote servers and, as a result, help to conserve battery life.

4.2 Custom Settings

Use the HMT140 Utility to make additional changes to the network configuration settings of an HMT140 data logger.

4.2.1 Modify Transmission Settings

Before making changes to transmission settings, consider the impact to battery life.

- ▶ 1. Make sure the HMT140 cover is open and the correct batteries are installed.
2. Turn on the HMT140 and wait five seconds to make sure the startup process completes.
3. Plug the USB connector on the HMT140 Configuration Cable to the computer, if it is not already connected.
4. From the **Start** menu, open the HMT140 Utility.
5. Connect the end of the HMT140 Configuration Cable labelled **USB Wi- Fi Programmer**, to the 4-pin HMT140 CONFIG header.
6. On the HMT140 Utility **Setup** tab, click **Retrieve** to identify the HMT140 and view current settings.

7. On the **Sensor** tab, select from the following options:

- **Transmit Period:** Select how frequently the HMT140 transmits data. In the event of an alarm condition, transmission frequency is overridden automatically. If you require a faster transmit period, the HMT140 Utility version 1.1.4.0 and higher provide additional options. Select the **Options** menu and then **Advanced**. Check the option **Extended Transmit**.
- **Tries:** Select the number of transmission attempts permitted for the specified Transmit Period.



CAUTION! Increasing the transmission frequency will deplete batteries more rapidly.

Vaisala HMT140 Utility

File Edit Options Help

Setup Status Tools Info

Saved Settings: [Dropdown] [Folder Icon] Dual 5V

Network: Sensor [I/O Definition] Description

Sensor

Transmit Period: 15 min. [Dropdown]

Tries: 3 [Dropdown]

Logging Period: 10 min. [Dropdown]

Options

Enable Push Button Control of Beeper

Enable Proximity Attention Sensor

Display On Time: 10 sec [Dropdown]

HMP110 Polltime: [Dropdown]

Low Battery Alert: 10% [Dropdown]

Stop Xmit at Battery Remaining: 5% [Dropdown]

Display Contrast

Contrast

50 [Slider] %

Set

Display Contrast is an interactive control. Click the up, down, or Set buttons to immediately set the contrast. Display Contrast will not be updated when "Update" is clicked. Display Contrast is ONLY settable and cannot be read with "Retrieve"

Update

Retrieve

Found USB Programmer Modified

For example, if you select 15 minutes for the **Transmit Period**, and 3 for the number of **Tries**, the HMT140 will attempt to transmit every 15 minutes. If the transmission does not complete successfully, it will make two additional transmission attempts, then will go into 'sleep' mode until the next scheduled transmit period.

- **Logging Period:** Specify how often the HMT140 will log I/O into the log buffer. If you are using HMT140 Utility version 1.1.4.0 or higher and require a more frequent log period, select the **Options** menu then **Advanced**, and check the option, **Log Periods**.
- **Enable Beeper/Enable Push Button Control of Beeper:** Select the option to enable or disable the button control of the Beeper (whether you want to be able to turn the Beeper on or off with the push button on the HMT140). It is also possible to turn the Beeper on and off by holding down the **SERVICE** button for approximately five seconds. The Beeper is enabled by default. There is no external Beeper status indicator. It must be enabled/disabled with the **SERVICE** button.
- **Enable Proximity Attention Sensor:** Select this option to enable or disable the proximity attention sensor. The sensor is used to wake up the HMT140, turn on the display (if present), and to force the HMT140 to send a data packet to the host. If your HMT140 does not have an LCD or is installed in an area where the IR sensor may be triggered more frequently (due to low-light, high-traffic or transmission obstacles), turn off the sensor to save battery life.
- **Display On Time:** Select the length of time the display stays on (choose a minimum length of time to save battery power).
- **HMP110 Polltime:** If your HMT140 uses an HMP110 Probe, select how frequently the HMT140 polls the HMP110 probe (leave at the default setting, two minutes, to save battery power).



The polling rate should be equal to or faster than the Logging Period, otherwise you will record the same measurement multiple times.

- **Low Battery Alert:** Specify at what percentage of battery power remaining you want the Low Battery indicator to display and notify the host software.
 - **Stop Xmit at Battery Remaining:** Specify at what percentage of battery power remaining you want the HMT140 to stop transmitting data to the host (to save battery power). Once this threshold is reached, the HMT140 continues to log data and function normally, but it will not transmit data using the Wi-Fi radio.
8. Use the **Display Contrast** interactive control to set the HMT140 display contrast. When the **Up**, **Down** or **Set** buttons are clicked, the HMT140 Utility will attempt to set the contrast.



The contrast value can only be set when you click **Set**. The value is not set with the **Update** or **Retrieve** buttons.

9. Click **Update**. The HMT140 Utility will send these settings to the HMT140 and then reboot. After the settings are successfully configured, a dialog displays **Configured!**. If there was an error sending the settings, the HMT140 Utility will display the error in a popup dialog window. The center panel in the bottom status bar will display the update status.

10. Select the **Status** tab to check that the settings appear as configured. Click **Get** if they do not appear automatically.
11. Disconnect the HMT140 Configuration Cable from the HMT140 and wait eight seconds.
12. Press the **SERVICE** button on the HMT140.
Optional: Enter a name for the saved settings on the **Set up** tab in the **Saved Settings** field and click the disk icon to save. If the HMT140 is used with more than one wireless network, enter a name in the **Saved Network Settings** field and click **Save**. Other network settings files can be saved and recalled from the **Saved Settings** field.

More Information

- [Options and Accessories \(page 10\)](#)
- [Battery Usage \(page 36\)](#)
- [Viewing Battery Life Remaining \(page 36\)](#)

4.2.2 Modify HMT140 Description

If you want to make it easier to identify specific HMT140 data loggers, enter custom names. By default, each HMT140 is identified using the model name and channel type.



Check with your network administrator before making changes.

To modify your HMT140 name and channel descriptions:

- ▶ 1. Complete steps 1 to 6 in [Modify Transmission Settings \(page 28\)](#).
2. Select the **Description** tab and enter a name, and/or Channel descriptions. You can view these descriptions in viewLinc, and make changes in viewLinc if required.

4.2.3 Check Transmission Status

The **Status** page displays the current state of the IP settings, connection status, signal strength, and battery life parameters, as applied using the **Update** button on the **Network** tab.

To monitor the transmission status:

- ▶ 1. On the **Status** tab, click **Get** to update the HMT140 Utility window with the latest status information: IP settings, WLAN and Sensor battery. If successful, the HMT140 Utility displays the information on the **Status** page.

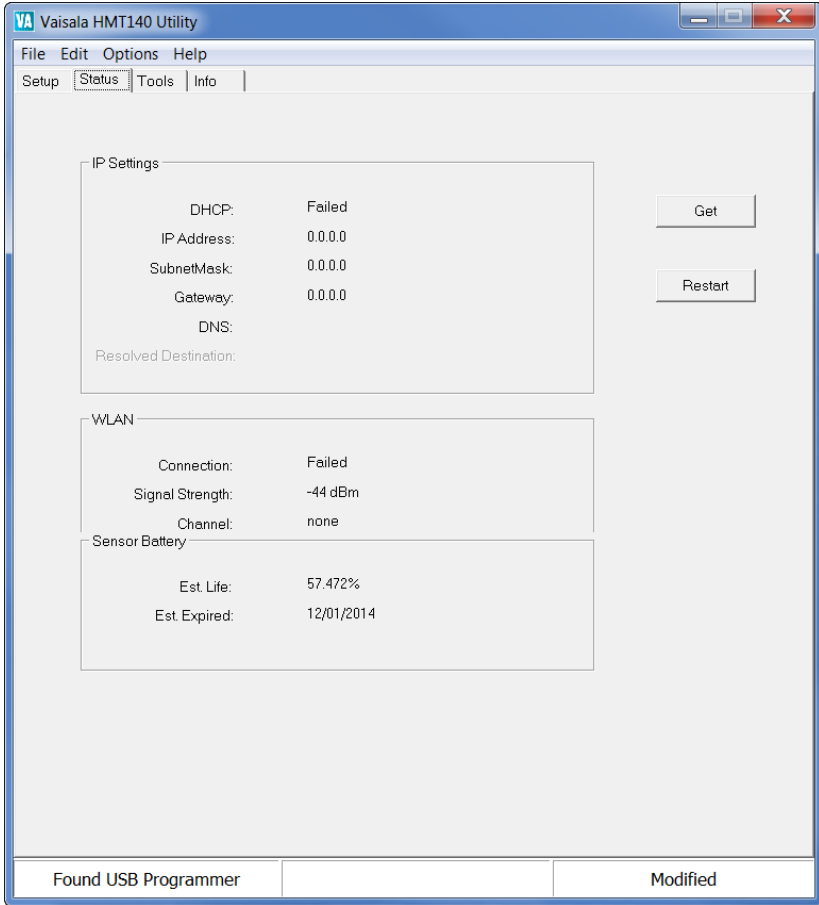

2. Read **IP Settings** status.
 - **DHCP:**
 - **Off** – static IP address information is being used
 - **On** – IP settings are successfully assigned
 - **Cache** – IP settings are successfully assigned and the HMT140 will cache this IP address
 - **Failed** – the HMT140 could not obtain the IP settings.
 - **IP Address:** Current IP address. If “0.0.0.0”, then no IP address has been assigned.
 - **Subnet Mask:** Current assigned subnet mask.
 - **Gateway:** Current assigned gateway address.
 - **DNS:** Current assigned Name Server address.
 - **Resolved Destination:** Appears if the hostname is given for the Destination.
3. Read **WLAN** status.
 - **Connection:**
 - **Failed:** The HMT140 has failed to connect to a wireless network.
 - **Associated - Not Connected:** The HMT140 has associated with the network but has not connected.
 - **Authenticated - Not Connected:** Security settings have been authenticated but has not connected.
 - **Assoc/Authen - Connected:** The HMT140 has associated and authenticated to the network and connected successfully to the network.
 - **Signal Strength:** Signal strength of the last communications. The signal strength can vary from reading to reading. Multiple samples should be taken to determine the signal strength.
 - **Channel:** This is the channel found during the Channel Auto Find feature or the channel set in the **Setup** page. If the HMT140 cannot find a channel when in Auto Find mode, the utility will display “none”.
4. Check HMT140 battery status.
 - **Est. Life:** Estimated percentage remaining of the battery.
 - **Est. Expired:** Estimated date when the battery should be changed (dependent on the **Transmit Period** and the number of alarms).

More Information

- [Battery Usage \(page 36\)](#)
- [Viewing Battery Life Remaining \(page 36\)](#)

4.3 HMT140 Function Modes

4.3.1 Operating Modes

The HMT140 operates in two modes: Config mode and Transmitter mode.

Config Mode

When the HMT140 is powered on, and the HMT140 Configuration Cable is connected to it, the HMT140 connects to the network for about two seconds and then goes to sleep. When new activity occurs, the HMT140 will wake again, connect, then go back to sleep after five seconds.

Transmitter Mode

When the HMT140 is powered on and the HMT140 Configuration Cable is not plugged into it, data is transmitted according to the transmit settings.

In Transmitter mode, the HMT140 spends most of its time in a very low power state (sleep) to save battery power. When a transmit period is due, it powers up the radio, attempts to link to the specified wireless network, transmits its data and then goes back to sleep. The HMT140 transmits based on the configured transmit period or when it is entering an alarm state.

4.3.2 Transmission of Data

The HMT140 will go through the following steps in order to connect to a network and deliver data:

1. Associates with the network.
2. HMT140 authenticated by the network (depends on the type of security).
3. Requests IP from DHCP Server (if set to dynamic IP)
4. HMT140 receives request from Name Server IP address of hostname (if a hostname is used for the Destination address and DNS Server specified).
5. Sends data.
6. viewLinc returns acknowledgement.

4.3.3 Transmit Attempts

The HMT140 will initiate a Transmit Attempt repeatedly (typically every 30 seconds) until either an acknowledgement is received from the host, or the number of tries has been exhausted. It follows this transmission mechanism both when the transmit period arrives and for alarm attempts.



CAUTION! The HMT140 should not be turned on until a network is available for it to join. Without a valid network to join, the device will wait for the maximum allowable period for a response (**Transmit Period** multiplied by **Tries**), thereby rapidly draining its batteries.

4.3.4 Alarm-triggered Transmission

The HMT140 has the ability to initiate a Transmit Attempt based on an alarm, if this functionality is configured in viewLinc.

An alarm can be triggered either when the measured value exceeds a high threshold or goes below a low threshold for a period of time, as configured in viewLinc as HighHigh or LowLow threshold alarm settings. The HMT140 can also be configured to initiate a Transmit Attempt when it exits an alarm state. Refer to the *Vaisala viewLinc User Guide* for information about alarm settings.

4.4 Additional Settings

4.4.1 Change Input/Output Scale

If you want your HMT140 to provide more meaningful voltage or current output measurements, you can modify the output settings (if you are not sure if your network requires or supports this option, contact Vaisala Technical Support for assistance).

To modify voltage or current input/output values:

1. From the **Setup** tab, select the **I/O Definition** tab.

The screenshot displays the 'I/O Definition' configuration window. At the top, there are tabs for 'Network', 'Sensor', 'I/O Definition', and 'Description'. The 'I/O Definition' tab is active. On the left, there are two channel labels: 'Ch1: 20mA' and 'Ch2: 20mA'. The main area is divided into two sections: 'Input Range' and 'Display Units'. The 'Input Range' section has two rows: 'Full Scale' (100%) with 'High (mA)' set to 20, and '20%' with 'Low (mA)' set to 4. Arrows point from these input range values to the 'Display Units' section. The 'Display Units' section includes a 'Decimals' dropdown set to 3, and 'High', 'Low', and 'Units' fields. 'High' is set to 50, 'Low' is set to 0, and 'Units' is set to 'psi'.

2. Enter the input range values of the HMT140.

3. Enter required **Display Units**, the number of decimal places you want recorded, the high/low output values and desired measurement units.

4.4.2 Save and Recall Settings

Your setup parameters can be saved and associated with a name on the **Setup** tab, in the **Saved Settings** field. These setup parameters can then be recalled by that name, saving you time reentering the settings.

The network parameters can also be saved separately and associated with a name on the **Network** tab, in the **Saved Network Settings** field. The network setup parameters can then be recalled by that name.

4.4.3 Delete Saved Settings

Both the **Saved Settings** and the **Saved Network Settings** can be deleted, to help keep the list of saved settings easier to view and/or manage.

- ▶ 1. On the **File** menu, select **Delete Sensor Setup** or **Delete Network Setup**, then choose the correct settings name to delete.

4.4.4 Restart the HMT140

You may want to reboot your HMT140 to reconnect to the network and re-acquire status information.

- ▶ 1. On the **Status** tab, click **Restart**.

4.4.5 Get General Information

To gather general information about the HMT140, select the **Info** tab and then click **Get**. The HMT140 Utility will retrieve the following information:

- MAC address
- Firmware version
- HMT140 serial number
- HMP110 serial number (if using)

4.5 Battery Usage

The HMT140 has a built-in battery meter. The meter provides a general estimate of battery power remaining by calculating the number of transmission attempts relative to the number of transmissions expected from the battery.

4.5.1 Viewing Battery Life Remaining

The HMT140 Utility displays the estimated battery expiration and the estimated battery life percentages on the **Status** page.

To improve battery life, consider increasing the amount of time between transmit periods.

Transmit Period (Minutes)	Estimated Battery Life (Months)
15	18
10	12
5	6
2	2.4

To view battery life remaining, view the battery meter status in the **Est. Life field** in the **Status** tab.

To reset the battery meter:



The meter must be reset after installing new batteries to ensure the battery meter status estimate is accurate.

- ▶ 1. Turn off the HMT140. Make sure the Configuration Cable is disconnected.
2. After replacing batteries, press and hold the **SERVICE** button.
 - Turn the HMT140 power switch on while the **SERVICE** button is engaged.
 - Wait approximately 10 seconds until the LED light flashes and you hear several beeps.
3. Release the **SERVICE** button to complete the battery meter reset.
4. Confirm that the battery meter is reset:
 - Reconnect the Configuration Cable to the HMT140 and your PC.
 - Start the HMT140 Utility.
 - On the **Setup** tab click **Retrieve**.
 - On the **Status** tab the **Est. Life** field should indicate 100 %.

More Information

- [Battery Replacement \(page 48\)](#)

4.5.2 Units and Temperature

Use the **Options** menu to set the measurement units you want to display on screen.

To change display units:

- ▶ 1. On the **Options** tab, select **Units**.

4.5.3 Connection Performance

Consistent connection performance is essential for longevity of battery life. The HMT140 Utility can perform a test to indicate how well the HMT140 connects to the network, which provides an indication about the expected battery life.



If the average connection time is more than five seconds, the HMT140 may not connect consistently and the battery may be exhausted before the battery meter indicates.

More Information

- [Test Network Connectivity \(page 43\)](#)

4.5.3.1 Connect Times

The following are the components of the connect time:

Table 3 Connect Time Components

Description	Option	802.11b (sec)	802.11g (sec) Cache/Noncache
HMT140 Startup	No	2	0.1
Auto Find Channel	Yes	1	0.1
Associate/Authentication	No	< 1	< 1
DHCP lookup	Yes	< 1	< 1
DNS lookup	Yes	< 1	< 1

4.5.3.2 Determining Connection Problems

In some networks, one of the optional components of the connect time may take too long to perform on a consistent basis. If the average connection time is too long it is important to try isolate the cause.

To isolate a connection problem:

- ▶ 1. Open the HMT140 Utility and connect the Configuration Cable to the HMT140 and your PC.
- 2. Temporarily turn off one of the connection options and then measure the average connection time:
 - Try setting the dynamically assigned IP address as the static address temporarily, or,
 - Try using a Destination IP address instead of the hostname address temporarily.

3. Select the **Tools** tab. In the **Test Connect Time** area, click **Start**. The HMT140 Utility will repeatedly attempt to connect to the network with one second between connection attempts. You can then view:
 - Number of connection attempts.
 - Last connect time.
 - Average, minimum and maximum connect times.
 - History of connect attempts displayed as a bar graph (each bar graph is the number of seconds for the attempt).
 - Failed connection attempts displayed as a grey bar. Failed connection attempts are not factored in the statistics.
4. To change the **Connect Window** time, on the **Options** menu select **Advanced Options**, and then select the desired **Connect Window** time.

4.6 Advanced Options

These advanced parameters (**Options > Advanced Options**) are applied each time an **Update** function is performed (available in HMT140 Utility version 1.1.4.0 and higher).



CAUTION! Modification of these parameters may negatively impact transmission performance and reduce battery life.

- **Extended Transmit, Log Periods and HMP Polltime:** Adds an additional transmission, logging and polling time periods on the **Sensor** tab. These additional periods are meant to be used for testing, evaluation and demonstration of the HMT140 and, if used regularly, can have a severe impact on battery life.
- **Log Conversations:** When this option is selected, the HMT140 Utility will capture the conversation between the utility and the HMT140 and place it in a file called OutputLog.txt. To locate the file, go to the **Help** menu, select **Utility Folder Paths**, and then **Explore Data**.
- **DHCP Caching:** When this option is selected, the HMT140 will cache its IP address assigned from the DHCP server until the DHCP lease time has expired or the HMT140 is power-cycled. If not selected, the HMT140 will request an IP address each time it attempts to contact the host.
- **ARP Caching:** When this option is selected, the HMT140 will store and keep a list of IP/MAC relationships. If not selected, the HMT140 will rebuild the IP/MAC relationships with every attempt to contact the host.
- **DNS Caching:** When this option is selected, the HMT140 will cache the IP address that results from the DNS lookup of the Destination hostname. The HMT140 will keep the destination IP address until either the DHCP lease time expires or the HMT140 is power-cycled. If not selected, the HMT140 will request a DNS lookup of the Destination hostname each time it attempts to contact the host. This setting is not recommended for most monitoring systems.
- **Allow Channels 12 and 13:** Enable the use of channels 12 and 13. This option should only be used in regions in where these channels are not restricted.

- **Connect Window:** Set the amount of time in seconds (three to eight seconds) that the HMT140 will attempt to associate and authenticate to an access point or a wireless router (this includes the time to obtain an IP address from a DHCP server). The default rate is five seconds.
- **Data Rate:** The default data rate is 1 Mbit/sec. and can be set from one to 54 Mbit/sec. The lower the data rate the longer range the HMT140 will have. The 802.11b data rates are: 1, 2, 5.5 and 11. All other data rates are 802.11g data rates. An access point or wireless router may be configured to exclude 802.11b data rates.
- **Override Destination Port:** Leave blank to not use this feature. If a number (1 to 65535) is placed in this field, the Utility will force the Destination Port to use this entered number. Use this feature to force the Destination Port to another value other than the default 6767.

4.6.1 Passwords

To improve security, you can require that a user log in to make changes to HMT140 parameters. If Passwords are enabled, a password prompt appears when a user clicks **Update** on the **Setup** tab. No other HMT140 functions will require a login password.



CAUTION! Use of passwords in the HMT140 is not recommended for use with Vaisala viewLinc software. Passwords may limit the ability of viewLinc to update settings or values in the device. For example, changes to a threshold alarm template in viewLinc may not transfer to the HMT140 if passwords are required on the device.

To set, change or remove an HMT140 password:

- ▶ 1. Open the HMT140 Utility.
2. Connect the HMT140 to your computer.
3. From the **Options** menu, select **Advanced Options**.
4. On the **Advanced Options** window, check **Enable use of passwords in HMT140**, then click **OK**.
5. To set the password for the first time:
 - Leave the **Current Password** field blank.
 - Check the **Change Password** option.
 - Enter the new password in the **New Password** and **New Password Again** fields.
 - Click **Update**.
6. To change an existing password:
 - Enter the current password.
 - Check the **Change Password** option.
 - Enter the new password in the **New Password** and **New Password Again** fields.
 - Click **Update**.
7. To clear a password:
 - Enter the current password.
 - Check the **Change Password** option, and leave the **New Password** and **New Password Again** fields blank.
 - Click **Update**.



CAUTION! Record the password in a safe location for safe-keeping; the HMT140 does not save the password. If the password is forgotten, contact Vaisala Technical Support.

4.6.2 Set Up a New Channel

On the **Network** tab, you can select a specific channel to view, using the **Channel** field.

To select multiple channels for the HMT140 to search when connecting to an access point or a wireless router, select **Auto Find**.



The Channel Auto Find feature defaults to search for channels 1 through 11. These channels are set in the .INI file of HMT140 Utility.

For Wi-Fi 802.11b radio mode, do not set the Channel Auto Find search channels to more than 3 channels. This will have an effect on the range and battery life of the HMT140.

For Wi-Fi 802.11g radio mode, the HMT140 can search all channels with minimal effect on battery life and range.

More Information

- [Additional Program Parameters \(page 43\)](#)

4.6.3 Find Additional Networks

To locate additional networks:

- ▶ 1. On the **Setup** tab, on the **Network** page, click the **Find Networks** button to scan for all available wireless networks. The HMT140 Utility displays details about the currently available networks: **SSID**: SSID of the access point or router (wireless channel).
 - **MAC**: MAC address of the access point or router.
 - **Channel**: Channel of the access point or router.
 - **Security**: Security setting of the access point or router. Note that some security settings will not work with the HMT140.
 - **RSSI**: Current signal strength.

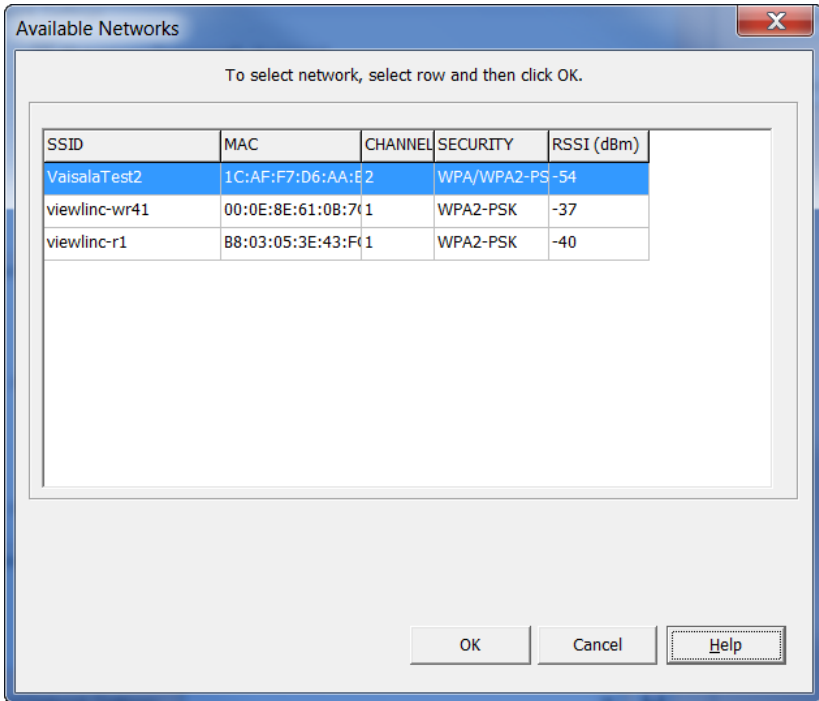

- 2. To select a network, click on the row in the **Available Networks** window, then click **OK**. The HMT140 Utility automatically places the network settings information in the appropriate fields in the **Setup** tab.



During the Find Networks operation, the HMT140 is disconnected from the current network. To reconnect, either click **Update** on the **Setup** tab or click **Restart** on the **Status** tab.

4.6.4 Test Network Connectivity

Ping from Sensor

For radio module version 2.27 and earlier (Utility > **Info** tab): When the **Ping From Sensor** button is clicked, the HMT140 will use either the IP address in the IP Address field or the current address in the Destination IP field in the **Setup** tab and ping that specified address. Once the ping operation is complete, the utility will either indicated failed or success and specify the IP address in the **Result** field.

Ping from This PC

When the **Ping From This PC** button is clicked, the HMT140 will use either the IP address in the IP Address field or the current address in the Destination IP field in the **Setup** tab and ping that specified address from the local PC. Once the ping operation is complete, the utility will either indicated failed or success and specify the IP address in the **Result** field.

Contact Destination Host

The HMT140 Utility will instruct the HMT140 to send a transmission (data packet) to the Destination Address. If the Destination responds with an acknowledgement, the Utility will indicate success, otherwise the Utility will display "Failed" in the **Result** field. Use the Contact Destination Host function to confirm that the HMT140 is sending packets to the Destination.



The Destination must be capable of responding with an acknowledgement for this function to work.

4.7 Additional Program Parameters

The HMT140 Utility stores all program information in an INI text file, *HMT140Utility.INI*. You can use this file for reference, and, if you are updating several HMT140 loggers, save time by making edits to the file directly.

To modify the *HMT140Utility.INI* file:

- ▶ 1. Go to the **Help** menu, select **Utility Folder Paths**, and then select **Explore Setup**.
2. Double-click the file, *HMT140Utility.INI*. It will open in a text editor.
3. To set the maximum number of tries (updates the **Tries** field, default maximum is 5):

```
[Settings]
MaxNumTries=5
```

4. To modify the default UDP port (default is 6767): code

```
[Settings]  
DefaultPort=6767
```

5. To specify the auto find channels:

```
[Settings]  
ChannelMask=1,2,3,4,5,6,7,8,9,10,11
```

6. Restart the HMT140 Utility to apply the changes.

5. Maintenance

5.1 Improving Sensor Response Time

To ensure maximum operating life and a fast sensor response time, replace a dirty filter. The filter should be replaced when it is damaged or dirty. Do not attempt to clean the filter.

To change the filter:

- ▶ 1. Turn the filter counter-clockwise to loosen it.
- 2. Remove the filter from the probe.



CAUTION! Be careful not to touch the sensors with the filter. Without the filter in place, the sensors are easily damaged – handle the probe carefully.

- 3. Install a new filter on the probe, and tighten it so it is finger-tight.
- 4. Make sure the filter sits straight and meets the threads properly.

5.2 Removing and Fastening Probes

5.2.1 Fixed Probe Model

To remove and replace a fixed probe:

- ▶ 1. Loosen the metal locking bushing by carefully turning it counter clockwise.
- 2. Remove the probe from the HMT140 by pulling it gently outwards.
- 3. Attach the new probe to the 4-pin M8 panel connector on the HMT140 (only one position possible).

4. Tighten the locking bushing to the M8 panel connector by turning it clockwise.

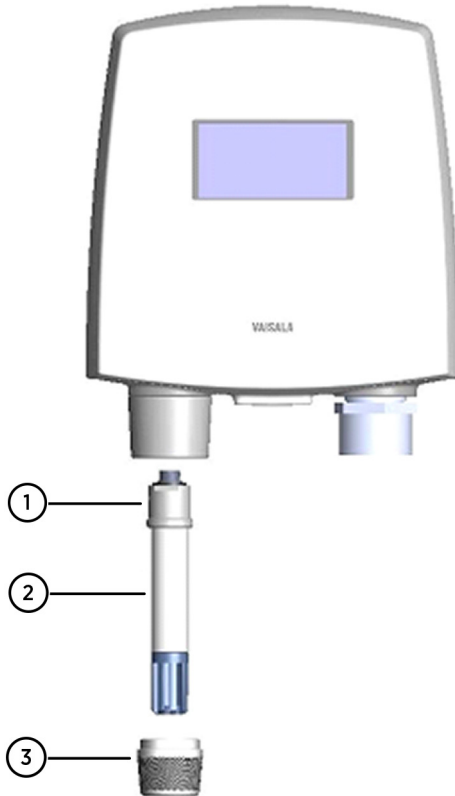

Figure 14 Fixed Probe Model

- 1 Holder bushing (attached permanently to the probe)
- 2 HMP110 probe
- 3 Locking bushing

5.2.2 Remote Probe Model

To remove and replace a remote probe:

- ▶ 1. Unscrew the small sleeve at the end of the probe cable that secures the probe in place, and pull out the probe.

2. Replace the probe and screw the small sleeve back on, securing the probe tightly in place.

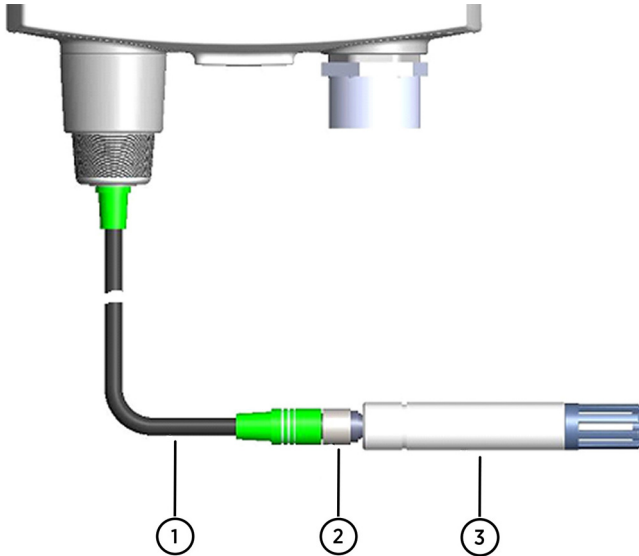

Figure 15 Remote Probe Model

- 1 Probe cable
- 2 Sleeve securing the probe to the cable
- 3 HMP110 probe

5.3 Calibration and Adjustment

HMP110 probe calibration status can be viewed with the HMT140 Utility. Calibration settings are adjusted using viewLinc.

To view probe calibration status:

- ▶ 1. On the **Info** tab, click **Get**. This page will display calibration information including calibration date, calibrator, and next calibration due date.

Please refer to the *Vaisala viewLinc User Guide* for further information, or visit www.vaisala.com/viewlinc.

For calibration of HMP110 probes, refer to the supporting documentation available on the Vaisala website.

5.4 Battery Replacement

When replacing batteries, it is important to use new, recommended batteries and to reset the battery meter to make sure an accurate estimate of battery life remaining.

To replace the batteries and reset the battery meter of the HMT140:

- ▶ 1. Open the HMT140 cover.
2. Turn the power switch off.
3. Remove the batteries by pulling them up firmly. If the battery does not come out easily, gently pull back on one of the battery holder tabs first.
4. Reset the battery meter:
 - Press and hold the **SERVICE** button.
 - Turn the power switch on.
 - Wait approximately 10 seconds until the LED light flashes and you hear several beeps.
5. Release the **SERVICE** button.
6. Confirm that the battery meter is reset:
 - Reconnect the Configuration Cable to the HMT140 and your PC.
 - Start the HMT140 Utility.
 - On the **Setup** tab, click **Retrieve**.
 - On the **Status** tab, the **Est. Life** field should indicate 100 %

More Information

- [Options and Accessories \(page 10\)](#)

6. Troubleshooting

Use HMT140 Utility to help troubleshoot issues that may occur while connecting the HMT140 to a wireless network.

6.1 HMT140 Operation Mode

When the Configuration Cable is connected to the HMT140, it enters Config mode. In this mode, the HMT140 continuously attempts to connect to the wireless network and stays connected until the Configuration Cable is disconnected or the setup has changed.

The HMT140 is in Transmitter mode when the Configuration Cable is not connected, and the HMT140 power switch is turned on. When in Transmitter mode, the HMT140 remains in a low power state, but will turn on, connect, transmit a UDP packet, and then go back to the low power state when it is ready to transmit.

6.2 Signal Strength

The HMT140 works best with signal strengths above -63 dBm (for 802.11b mode) and -75 dBm (for 802.11g mode). If the signal strength is less, the HMT140 may work marginally or not at all. Stronger signal strength improves transmission performance.

Since the signal strength will vary from sample to sample, you should take multiple samples to determine the signal strength. View signal strength on the **Status** tab and in the **Available Networks** window (click the **Find Networks** button on the **Setup** tab).

6.3 Indicator Lights

The red LED on the main board (Center, or below LCD) indicates that a transmit attempt has just started. The LED on the radio module indicates that radio module is connected to the network. When in Transmitter mode the LED will flash when a connection is made. When in Config mode (the programming cable is connected to the HMT140) the LED will remain on continuously when a connection is established.

6.4 Access Points

Some access points have a mode called Auto Channel mode where it will move between up to 11 channels. If the access point is using this feature the HMT140 may work properly in Config mode, but could fail or work very marginally in Transmitter mode. If the access point is using Auto Channel mode, make sure the HMT140 has "Auto Find" for the channel and the right channels have been selected for "Auto Find" channels.

Some access points will move between three channels (typically 1, 6, and 11). The HMT140 Utility will work with these access points with the Channel Auto Find feature but the channels that are used must match the channels for which the HMT140 is configured.

6.5 Transmit Cycle

In Transmitter mode, it can take up to five seconds for the transmit cycle to complete. Transmit time is calculated from when the **SERVICE** button is pressed to when the acknowledgement is received from the host.

6.6 Frequently Asked Questions

Is the connect time too long?

If the connect time to the network is consistently long (over five seconds), the HMT140 may not be able to connect to the network. If you suspect the connect time to the network is long:

1. Use the **Test Connect Time** tool (see [Determining Connection Problems \(page 38\)](#)), or,
2. Use a PC to connect to the network and then measure the time it takes to connect.
3. If the network consistently takes longer than five seconds to connect, you may need to adjust the settings:
 - Set the **Connect Window** to a longer value (use the **Connect Time** tool to help determine this value) or,
 - Change a connection component like channel Auto Find or DHCP.



Extending the connect time may decrease battery life.

Why can't I connect to the wireless network?

1. Verify that the network exists.
2. Verify signal strength. Use the built-in signal strength meter. Determine if adequate signal strength exists at that location. See [Signal Strength \(page 49\)](#).
3. Verify your network settings.
4. Make sure the router or Access Point accepts connections of 1 Mbps. Some access points may be set up to exclude certain WLAN data rates. You may have to change the WLAN data rate setting in the HMT140.
5. If the HMT140 was previously connected at one location, but will not connect at the new location, temporarily move it to the previous location and verify operation. It is also possible that a setting on the network has changed.

I can connect to the network, but cannot obtain a dynamic IP address

1. Verify your network settings.
2. Verify that you are connected to the right network.
3. Use the **Ping from PC** function in the HMT140 Utility to see if your PC can ping an address on that network (your PC must be connected to that network).

4. Use the **Ping from PC** function in the HMT140 Utility (if this PC is connected) and see if you can ping the HMT140 when it is in Config mode. Go to the **Status** tab to determine the IP address.
5. Use a static IP address temporarily and connect to the network to determine if HMT140 transmissions are being received by the host.
6. Make sure the DHCP Server has not exhausted the number of assignable IP addresses.
7. Check if the DHCP Server needs to be configured to accept this type of device (it is possible the DHCP Server is taking too long to respond to the request).

I can connect to the network, but host is not receiving UDP packets

1. Verify your network settings.
2. Verify that you are connected to the right network.
3. Verify that the Destination IP address is correct.
4. If using the broadcast address, verify that the network can support broadcasts. Most routers by default will not route broadcast traffic.
5. **Use the Ping from PC** feature if this PC is connected or a PC on the network and ping the host. Also try pinging the HMT140 when it is in Config mode.
6. Check the following:
 - Is the host is ready to receive the transmit packets?
 - Is the host configured to listen for the UDP packets?
 - Is the host software running?
 - Is firewall software installed at the host that would prevent the UDP traffic?
 - Is there anything on the network that would restrict packets from being routed (like MAC filtering)?
7. Perform a destination test (use the **Contact Destination Host** function from the **Tools** tab).
8. If using a hostname for the destination address, make sure the DNS address is correct (whether set as static or obtained through the DHCP server).
9. Check if the hostname is being resolved in Config mode (go to the HMT140 Utility **Status** tab and examine the **Resolved Destination** field).

I can connect to the network and Contact Destination using the utility, but host is not receiving UDP packets in Transmitter mode

1. Verify your network settings.
2. Check if the access point using Auto Channel mode is switching between channels. The access point may have switched to a different channel than is set up in the HMT140.

- Use the **Test Connect Time** tool in the utility to verify how long the HMT140 takes to connect to the network.
If the network consistently takes longer than five seconds to connect to the network, you may need to make adjustments to the settings. Set the connect time window to a longer value (use the **Test Connect Time** tool to help determine this value) or change a connection component like channel Auto Find or DHCP.



Extending the connect time may decrease battery life. The battery meter cannot be used to verify battery life remaining if connect times are set longer than the default.

- Verify the signal strength where the HMT140 is located. Also check how the HMT140 is mounted and oriented at this location with respect to the access point. For example, the HMT140 is mounted at the back of a refrigerator but may work better being mounted near the top of the refrigerator.
- Change batteries.

HMT140 Utility cannot find the HMT140

- Make sure the HMT140 Configuration Cable is connected to the HMT140.
- Disconnect the cable, power the HMT140 off, power back on, wait five seconds, connect the cable and try again.
- If the red LED in the programming cable flashes when doing an operation, disconnect the cable from the HMT140 and connect again.
- Disconnect the cable from the HMT140 and then disconnect the cable from the PC. Wait 30 seconds. Insert cable back into PC and into the HMT140.
- Reboot your computer.
- Use an externally powered USB Hub. Your computer may not be supplying enough power through the USB port.

HMT140 Utility network compatibility issue: Data is not reaching destination in Transmitter mode

While in Config mode, the HMT140 can connect (associate/authenticate) to the network and Contact Destination is successful but while in Transmitter mode, the data never reaches the destination. The UDP data packet from the HMT140 is not forwarded by the router.

Workaround:

- Use Dynamic IP and have DHCP Caching turned off. If the IP address is static or the DHCP Caching is enabled, these routers will not forward the UDP data packet of the HMT140.
- Replace the router (contact Vaisala Technical Support).

Why does the battery meter indicate a lower battery life than expected?

- Confirm whether the battery meter was reset when the batteries were last changed. (See [Battery Usage \(page 36\)](#).)

2. Set a longer transmit period.
3. Check the HMT140. Was the **SERVICE** button pressed frequently?
4. Check alarm history. Were there a large number of alarms initiating more frequent transmission attempts?
5. Check transmission attempts. Is the setting for number of tries too high?
6. Check network quality. Is the connect time for the HMT140 greater than five seconds? Use the **Test Connect Time** tool in the HMT140 Utility.
7. Check the signal strength.

7. Technical Data

7.1 HMT140 Dimensions (Fixed Probe)

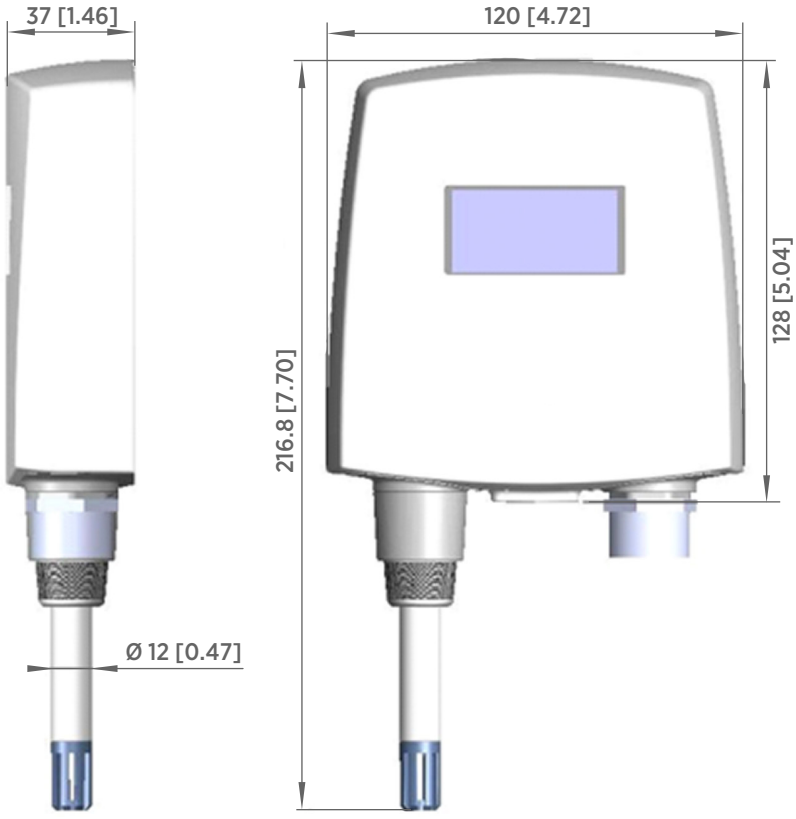

Figure 16 HMT140 Fixed Probe Dimensions in mm (in)

7.2 HMT140 Dimensions (Remote Probe)

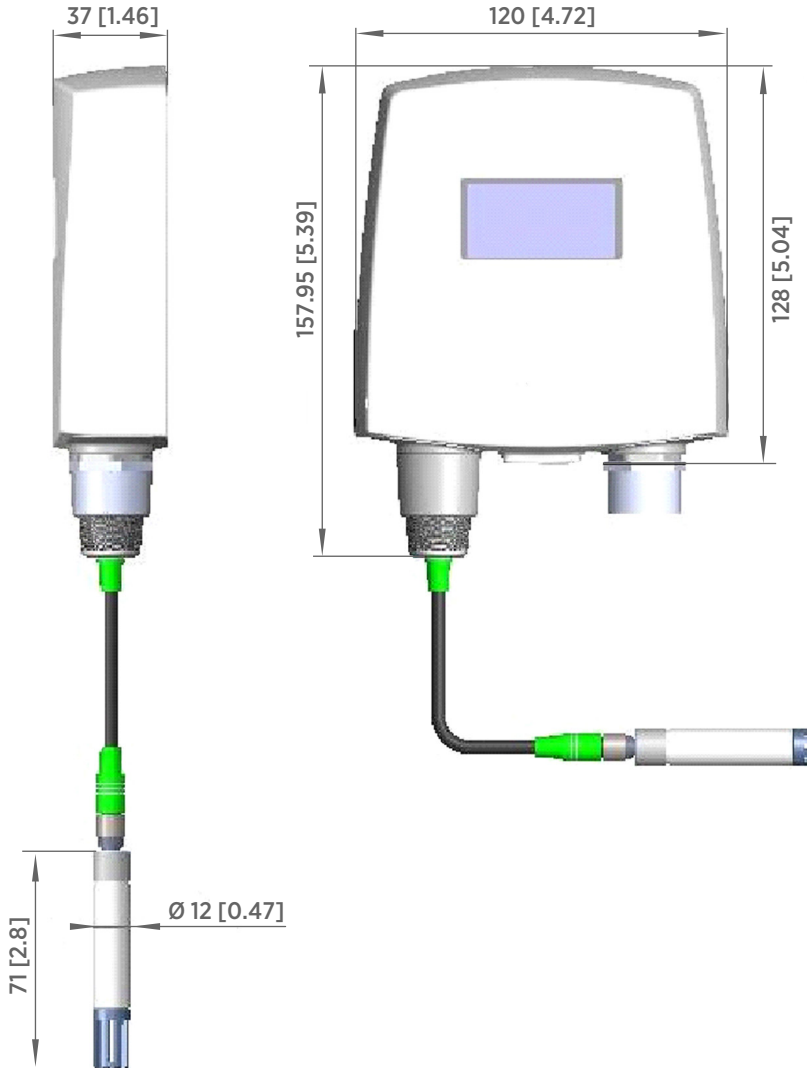

Figure 17 HMT140 Remote Probe Dimensions in mm (in)

7.3 HMT140 Product Specifications

Table 4 HUMICAP® Humidity and Temperature Probe HMP110

Property	Description/Value
Relative Humidity	
Measurement range	0 ... 100 %RH
Accuracy (incl. Non-Linearity, Hysteresis, and Repeatability):	
At temperature range 0 ... +40 °C (+32 ... +104 °F):	
0 ... 90 %RH	±1.5 %RH
90 ... 100 %RH	±2.5 %RH
At temperature range -40 ... 0 °C, +40 ... +80 °C (-40 ... +32 °F, +104 ... +176 °F):	
0 ... 90 %RH	±3.0 %RH
90 ... 100 %RH	±4.0 %RH
Factory calibration uncertainty at +20 °C (+68 °F)	±1.5 %RH
Humidity sensor	Vaisala HUMICAP® 180R
Stability	±2 %RH over 2 years
Temperature	
Measurement range	-40 ... +80 °C (-40 ... +176 °F)
Accuracy over Temperature Range:	
+15 ... +25 °C (+59 ... +77 °F)	±0.2 °C (±0.36 °F)
0 ... +15 °C, +25 ... +40 °C (+32 ... 59 °F, +77 ... +104 °F)	±0.25 °C (±0.45 °F)
-40 ... 0 °C, +40 ... +80 °C (-40 ... +32 °F, +104 ... +176 °F)	±0.4 °C (±0.72 °F)
Temperature sensor	Pt1000 RTD 1/3 Class B IEC 751
HMP110 probe	-40 ... +80 °C (-40 ... +176 °F)
Storage temperature	-50 ... +70 °C (-58 ... +158 °F)

Table 5 Temperature Probes

Property	Description/Value
Resistive Temperature Input Signals	
Temperature sensor	Pt100 RTD / 4 wire, Class A IEC 751

Property	Description/Value
Input impedance	5.1K Ω
Measurement range	-196 ... +90 °C (-320.8 ... +194 °F)
Accuracy over Temperature Range:	
-196 ... -90 °C (-320.8 ... -130 °F)	± 2.5 °C (± 4.5 °F)
-90 ... -30 °C (-130 ... -22 °F)	± 0.75 °C (± 1.35 °F)
-30 ... 0 °C (-22 ... +32 °F)	± 0.5 °C (± 0.9 °F)
0 ... +50 °C (+32 ... +122 °F)	± 0.25 °C (± 0.45 °F)
+50 ... +90 °C (+122 ... +194 °F)	± 0.75 °C (± 1.35 °F)

Table 6 Analog Inputs

Property	Description/Value
Current Input Signals	0 ... 22 mA
Resolution	0.67 μ A
Accuracy	± 0.15 % F.S. at +25 °C (+77 °F)
Input impedance	62 Ω
Overload protection	40 mA
Voltage Input Signals	0 ... 5 V, 0 ... 10 V
Resolution	0.0034 % F.S.
Accuracy	± 0.15 % F.S. at +25 °C (+77 °F)
Input impedance	37K Ω
Overload protection	50 V max.
Isolation	One common per logger
Contact Inputs	Open/Closed with magnetic reed switch cable connections (Dry Contact)

Table 7 Measurement Variants

Model	Measurement Channels
HMT141	1 Temperature and 1 Humidity Channel
HMT143	2 RTD Temperature Channels
HMT144	2 Voltage Inputs (0 ... 5 VDC)
HMT145	2 Voltage Inputs (0 ... 10 VDC)
HMT146	2 Current Inputs (0 ... 20 mA)

Model	Measurement Channels
HMT147	2 Door Contacts
HMT148	1 RTD Temperature and 1 Door Contact
HMT14D	1 RTD Temperature and 1 Current Input (0 ... 20 mA)
HMT14E	1 RTD Temperature and 1 Voltage Input (0 ... 5 VDC)
HMT14F	1 RTD Temperature and 1 Voltage Input (0 ... 10 VDC)

Table 8 Operating Environment

Property	Description/Value
Operating Temperature	
Data logger body, no display	-40 ... +60 °C (-40 ... +140 °F)
Data logger body, with display	-20 ... +60 °C (-4 ... +140 °F)
IP rating	IP65
Maximum operating altitude	2000 m (6 500 ft)

Table 9 General Specifications

Property	Description/Value
Memory	3,060 samples
Sample rate	User selectable (interval: 2 ... 60 minutes)
Display (optional)	128 x 64 resolution full graphics B&W display without backlight

Table 10 Mechanical Specifications

Property	Description/Value
Weight (with battery/without probe)	300 g (10.6 oz)
Screw terminals	26 AWG ... 20 AWG
HMP110 probe interface	4-pin M8 female panel connector
HMP110 probe cable lengths	3 m, 5 m, and 10 m (9.8 ft, 16.4 ft, and 32.8 ft)
Hermetic Door Switch Sensor cable length	7.6 m (24.9 ft)
Material	
Data logger housing	PBT plastic
Display window	PC plastic

Property	Description/Value
HMP110 probe body	Stainless steel (AISI 316)
HMP110 probe grid filter	Chrome coated ABS plastic
RTD Temperature Sensor	
Sensor tip material	Stainless steel (AISI 316)
Sensor tip length	50.8 mm (2 in)
Sensor tip diameter	4.76 mm (0.19 in)
Cable length	5 m (16.4 ft)

Table 11 Wireless



Property	Description/Value
Networking standards	IEEE 802.11b/g
Data rates	802.11b: up to 11 Mbps 802.11g: up to 54 Mbps
Frequency band	2402 - 2480 MHz
Wi-Fi Security	WEP (128-bit), WPA, WPA2 (Personal)
Output power	+18 dBm (63 mW)
Receiver Sensitivity	-85 dBm typical
Antenna	Onboard whip
Contains	FCC ID: U30-G2M5477 IC ID: 8169A-G2M5477 NCC ID: CCAF11LP0240T6
当該機器には電波法に基づく、技術基準適合証明等を受けた特定無線設備を装着している。	  201-125765

Table 12 Standards

Property	Description/Value
Electromagnetic compatibility	EN 61326-1B, EN 301 489-1, ¹⁾ EN 300 328 V2.1.1
Safety	EN 61010-1

1) EN 61326-1B and EN 301 489-1 apply only to the EU specific versions of HMT140 loggers with CE marking.



Region-specific standards and regulations are applied to wireless devices. The HMT140 logger versions with CE marking can be used in the following regions/countries. The list is subject to change without prior notice.

- EU countries
- The United States
- Australia
- Canada
- Iceland
- Japan
- Liechtenstein
- New Zealand
- Norway
- Taiwan

Table 13 Spare Parts and Accessories

Item	Order Code
HMP110	
Humidity and temperature probe	HMP110 ¹⁾
Humidity and temperature replacement probe	HMP110R ¹⁾
Humidity sensor	HUMICAP® 180R
Probe mounting flange	226061
Probe mounting clamps, 10 pcs	226067
Probe cable 3 m (9.8 ft)	HMT120Z300
Probe cable 5 m (16.4 ft)	HMT120Z500
Probe cable 10 m (32.8 ft)	HMT120Z1000
Duct installation kit	215619
Sensor Protection	
Plastic grid filter	DRW010522SP
Plastic grid with membrane filter	DRW010525SP
Stainless steel sintered filter	HM46670SP
Other Accessories	
RTD Temperature Probe 5 m (16.4 ft)	ASM210644SP
Hermetic Door Switch Sensor Kit	236319SP
Thermal Dampener Blocks	236310SP

Item	Order Code
Four Dual Lock™ Strips (76 mm/3 in)	237217SP

1) See separate order form.

Index

- A**
- advanced options..... 39
 - Auto Find Channels..... 41
- B**
- batteries
 - connection performance.....38
 - replacing..... 48
 - battery life
 - checking..... 36
 - extending.....28, 36
 - battery meter..... 48
 - viewing status..... 36
- C**
- calibration..... 47
 - viewing status..... 47
 - changing
 - input/output scale..... 35
 - Channels
 - Auto Find..... 41
 - compliance..... 17
 - connection performance..... 38
 - connection problems..... 38
- D**
- deleting settings..... 36
 - Duct Installation Kit.....22
- E**
- extending
 - transmit period..... 39
- F**
- fixed probe
 - removing and fastening..... 45
- G**
- Get general information..... 36
- H**
- HMT140
 - components..... 12
 - deleting settings..... 36
 - Fixed Probe Model..... 45
 - getting information..... 36
 - optional display..... 11
 - overview.....9
 - Remote Probe Model..... 46
 - restarting..... 36
 - HMT140Utility.INI file..... 43
 - HUMICAP® Sensor..... 45
- I**
- I/O scale..... 35
 - INI file..... 43
 - input/output scale..... 35
- L**
- Log conversations..... 39
- M**
- modifying .INI file..... 43
- N**
- network settings
 - deleting.....36
- O**
- opening transmitter cover.....19
 - optional display..... 11
- P**
- passwords
 - recording..... 40
 - passwords, about.....43
 - probe
 - removing/fastening..... 45, 46
 - Probe Mounting Clamp..... 24

R

recording passwords.....	40
removing/fastening	
fixed probe.....	45
remote probe.....	46
resetting battery meter.....	48
restarting a device.....	36

S

safety.....	16
Save/Recall Settings.....	36
settings	
deleting.....	36
specifications.....	56

T

troubleshooting.....	49
----------------------	----

V

viewing	
battery status.....	36
calibration status.....	47

Warranty

For standard warranty terms and conditions, see www.vaisala.com/warranty.

Please observe that any such warranty may not be valid in case of damage due to normal wear and tear, exceptional operating conditions, negligent handling or installation, or unauthorized modifications. Please see the applicable supply contract or Conditions of Sale for details of the warranty for each product.

Technical Support



Contact Vaisala technical support at helpdesk@vaisala.com. Provide at least the following supporting information:

- Product name, model, and serial number
- Name and location of the installation site
- Name and contact information of a technical person who can provide further information on the problem

For more information, see www.vaisala.com/support.

Recycling



Recycle all applicable material.



Follow the statutory regulations for disposing of the product and packaging.

VAISALA



**kenelec
scientific**
measuring up

Distributed by:

Kenelec Scientific Pty Ltd
1300 73 22 33
sales@kenelec.com.au
www.kenelec.com.au

www.vaisala.com

