

Using the TSI® Dilution Bridge with the Scanning Mobility Particle Sizer™ (SMPS™) Spectrometer



Model 3938

Application Note SMPS-013 (A4)

When the particle concentration is too high for measurement with a TSI® SMPS™ system, you can use a TSI® Dilution Bridge (TSI Part No. 1050001) to adjust the particle concentration. This is a very simple type of dilution system composed of a filter in parallel with a straight tube, with needle valves at each end that can be used to control the restriction in each branch, and therefore, the flow in each branch. More restriction in one branch means less flow in that branch, and vice versa. The dilution bridge is sometimes called a “leaky filter” diluter, as the straight branch, when combined with the adjustment needle valves, forms a sort of controlled leak around the filter, which removes practically all particles that flow through it, and therefore, reduces the concentration of the aerosol upon recombination of the two flow streams at the outlet of the device. A schematic of the device is shown below.

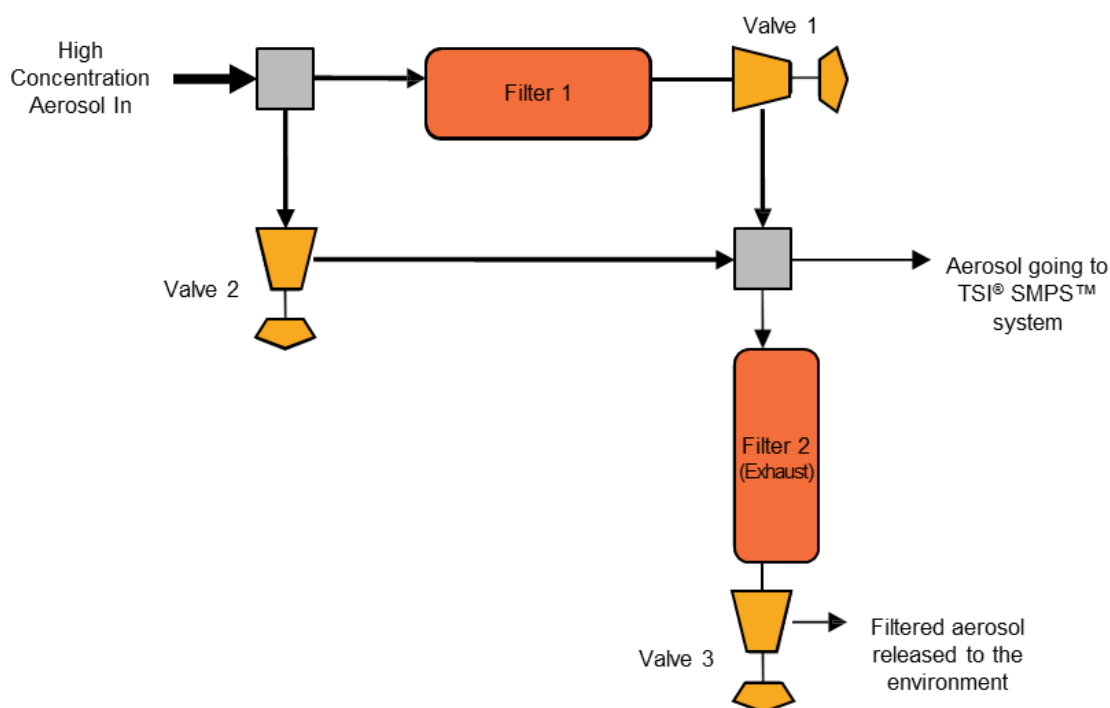

An additional flow balance branch is included at the outlet of the diluter for situations where the flow required by the instruments sampling through the diluter, or the desired outlet flow, does not match that of the aerosol being provided to the inlet of the diluter. This balance consists of a second filter and a third needle valve. The valve can be removed for a passive flow balance (i.e., the instruments will pull what they require, and flow is exhausted or made up as needed through this branch), or used to control the backpressure on the branch if the situation requires it. A flow meter such as a TSI® model 4048 field calibrator can be placed on this branch for measuring the bypass or makeup flow, if desired.

Because the dilution bridge is very simple in concept and construction, it is an inexpensive and easy-to-use solution for many general aerosol laboratory tasks. However, the dilution bridge has some limitations that should be considered prior to its use in critical applications:

1. It is not possible to know the exact dilution ratio solely from the position of the knobs. Only a general “more or less” or “higher or lower” level of dilution control is permitted. Additionally, further dilution occurs through the flow balance branch if the flow demanded by downstream instruments is less than that provided by the aerosol generator. This is because clean air will be pulled through the filter from the environment. A particle sizer or counter such as an SMPS™ system or CPC can be placed alternately upstream and downstream of the dilution bridge if desired, however, to measure the dilution ratio at the given valve settings. For applications where only a target downstream concentration is required, this is generally less of an issue.
2. The dilution bridge is an entirely manual diluter with no automatic drift compensation mechanism. As the fittings, needle valves, and filters load with aerosol, the pressure drops (restrictions) will change, causing the dilution ratio to drift somewhat over time. Similarly, the outlet flow balance can drift as well. This is especially important to consider for applications where the concentrations, and therefore loading rates, are very high. In the most extreme cases, the dilution bridge may need to be disassembled and cleaned (and the filters replaced) if there are flow blockages due to particle accumulation.
3. Since needle valves, tight radii, and small crevices exist in the plumbing, there will be nontrivial losses of particles. For this reason, the dilution bridge may not be the best choice for supermicron sampling applications where inertial losses must be minimized and isokinetic sampling is required, or for very small particle sizes where diffusion losses are high. The losses can be characterized in a manner similar to that of determining the dilution ratio as described above, if desired.
4. The dilution bridge is not intended for chemically reactive or corrosive aerosols, or high pressure or temperature applications, due to the limitations of the materials of construction.
5. Clean air coming from the filter and flow balance branch is recombined in a simple cross, which may not be adequate for mixing to produce a homogenous diluted aerosol. An additional static mixer or length of tubing may be needed downstream of the dilution bridge to promote this adequate mixing of clean air and aerosol before measurement.
6. The plumbing in the dilution bridge is designed for flows less than approximately 5 L/min.

To use the dilution bridge, simply plumb it inline in the aerosol sampling or generation system, and adjust the valves until the desired concentration is achieved. Always start with both valves fully open. To increase the concentration, slowly close the filter branch valve (Valve 1). To decrease the concentration, slowly close the straight branch valve (Valve 2). The other valve in the main pair can be used as a fine adjustment in each case to help dial in the desired dilution ratio. Wait several seconds (or until a scan has completed when using the SMPS™ system) before making further adjustments, as there will be some time delay for restabilization to occur; it can be easy to under or overshoot a concentration target if adjustments are made too quickly, especially if the system flow rates are low.

An example use of the flow balance valve is if an atomizer is pushing flow through an electrostatic classifier (most likely with an inlet impactor installed to provide some counter pressure) and the aerosol flow needs to be controlled to some value less than what is provided by that atomizer, such as is done in the model 3940A monodisperse aerosol generation system. The more open this valve is, the more flow will be allowed to escape through the filter as opposed to being pushed through the classifier, and vice versa. It is important to never under or over pressurize instruments in any scenario (sampling downstream of the classifier in this specific case), so always monitor inlet pressures, and incorporate an additional passive flow balance if needed. If the flow balance is not needed, the valve can be completely closed to form a system wherein the dilution bridge inlet and outlet flows are equal and the instruments downstream pull what they require through the dilution bridge.

A short bullet pointed summary of the above discussion for the two most common use cases is provided in closing.

1. When the aerosol generation system is creating more aerosol flow than what the SMPS™/CPC requires.
2. When the SMPS™/CPC can draw the aerosol required for analysis without any excess.

When the Aerosol Generation System is Creating more Aerosol Flow than what the SMPS™/CPC Requires

The high concentration aerosol enters the bridge and is split into two parts:

- Part one of the high concentration aerosol goes through a filter (Filter 1) to remove all particles.
- Part two of the high concentration aerosol is undiluted.
- Part one and part two are then joined back together.
- The ratio of filtered to unfiltered flow is controlled using Valve 1 after the filter and Valve 2 after the incoming flow is split on the undiluted aerosol flow.
- The exhaust filter is used to filter the excess aerosol from the generator before releasing it to the environment.
- Valve 3 is used to control this exhaust and balance the flows properly.

When the SMPS™/CPC can Draw the Aerosol Required for Analysis without any Excess

The high concentration aerosol enters the bridge and is split into two parts:

- Part one of the high concentration aerosol goes through a filter (Filter 1) to remove all particles.
- Part two of the high concentration aerosol is undiluted.
- Part one and part two are then joined back together.
- The ratio of filtered to unfiltered flow is controlled using Valve 1 after the filter and Valve 2 after the incoming flow is split on the undiluted aerosol flow.
- Valve 3 is not needed under these circumstances and can be closed.



Distributed by:

Kenelec Scientific Pty Ltd
1300 73 22 33
sales@kenelec.com.au
www.kenelec.com.au



Knowledge Beyond Measure.

TSI Incorporated – Visit our website www.tsi.com for more information.

USA Tel: +1 800 680 1220
UK Tel: +44 149 4 459200
France Tel: +33 1 41 19 21 99
Germany Tel: +49 241 523030

India Tel: +91 80 67877200
China Tel: +86 10 8219 7688
Singapore Tel: +65 6595 6388

TSI and TSI logo are registered trademarks of TSI Incorporated in the United States and may be protected under other country's trademark registrations.