

AEROSOL GENERATION MODEL 3940A

SUBMICROMETER MONODISPERSE AEROSOL
GENERATION SYSTEM

Using an Electrostatic Classifier (TSI Model 3082), the Model 3940A extracts a narrow monodisperse size range from polydisperse aerosol produced with an atomizer. The resulting monodisperse aerosol will typically have a geometric standard deviation of 1.05 micrometer or better.



Features and Benefits

- + Generates a highly monodisperse aerosol in the size range from 0.01 to 1.0 micrometer
- + Operator simply selects the operating parameters required to produce a known particle size
- + Operation is based on first principles, so no calibration is necessary

Applications

- This complete aerosol generation system is useful anywhere a precise, monodisperse, submicrometer aerosol is needed. Specific applications include:
- + Calibrating submicrometer counting and sizing instruments (condensation particle counters and optical particle counters) as described in JIS B 9921
 - + Testing HEPA, ULPA, and other high-efficiency filters as described in IES RP-CC007.1 and RP-CC021.1, and DIN 24183
 - + Studying nucleation, condensation, and diffusion
 - + Studying particle charge and electrical mobility
 - + Enhancing the monodispersity of PSL and other aerosols



UNDERSTANDING, ACCELERATED

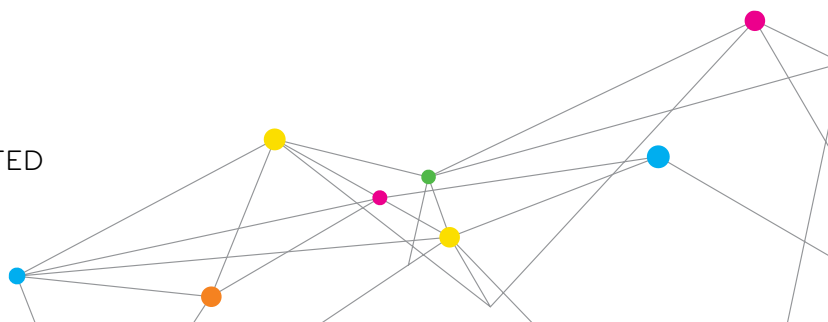

MODEL 3940A

OPERATION OVERVIEW

Operation

Compressed air first passes through a Filtered Air Supply, where the air is cleaned and dried. This conditioned air is used to power a Constant Output Atomizer. The atomizer generates an aerosol of polydisperse droplets with a count median diameter of 0.3 micrometer. It works with oils such as DOP and DEHS, most solutions with a volatile solvent, or suspensions such as PSL spheres in water. The aerosol droplets pass through a Diffusion Dryer where any volatile components evaporate off. The remaining particles then pass through Kr-85 bipolar chargers to establish a low-level charge equilibrium.

The Electrostatic Classifier used in the system contains a differential mobility analyzer (DMA). Inside the DMA, particles are subjected to an electric field. The field deflects the particles from their flowpath according to their electrical mobility, which is inversely proportional to particle size. By adjusting voltage levels, particles of a narrow size range are steered into a small exit. The particles leave the classifier as a monodisperse aerosol. Aerosol concentration is changed simply by adjusting valves so that a portion of the aerosol passes through high-efficiency filters. (For more information, see the Model 3082 Electrostatic Classifier product information sheet.)

Bibliography

Caldow R and J Blesener, A Procedure to Verify the Lower Counting Limit of Optical Particle Counters, *Journal of Parenteral Science and Technology*, July/August 1989. (TSI paper A62)

Kinney PK, DYH Pui, GW Mulholland, and NP Bryner, Use of the Electrostatic Classification Method to Size 0.1 μ m SRM Particles—A Feasibility Study, *Journal of Research of the National Institute of Standards and Technology* 96(2), March/April 1991. (TSI paper A74)

Liu BYH and DYH Pui, A Submicron Aerosol Standard and the Primary, Absolute Calibration of the Condensation Nuclei Counter, *Journal of Colloid and Interface Science* 47(1), April 1974. (TSI paper A81)

Liu BYH, DYH Pui, and KY Rubow, Performance of HEPA and ULPA Filters, Proceedings of the 1985 annual technical meeting of the Institute of Environmental Sciences. (TSI paper A47)

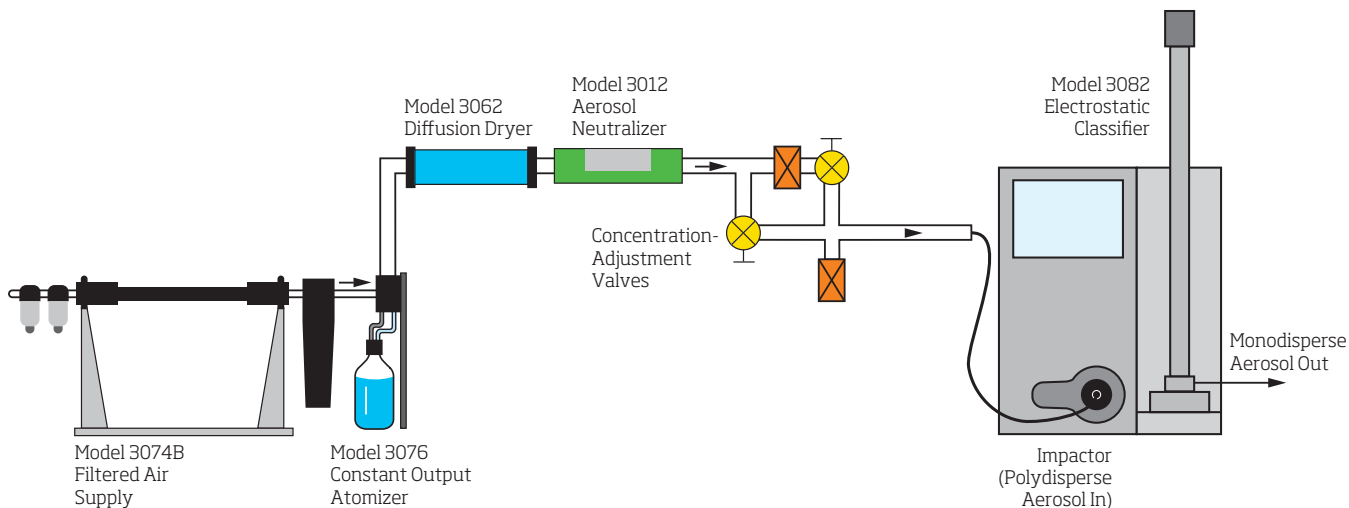

Optional Configuration

The standard Model 3940A system uses two neutralizers to ensure that particle charge is fully reduced to a Fuch's equilibrium before aerosol enters the DMA. By itself, the 3077A may not be adequate if the high-concentration aerosol generated by the atomizer is also highly charged.



This Model 3940A system is shown ready to calibrate a TSI Model 3082 Electrostatic Classifier. Ask your TSI representative about additional components needed for your particular application.

SPECIFICATIONS

SUBMICROMETER MONODISPERSE AEROSOL GENERATION SYSTEM MODEL 3940A

Refer to separate product sheets for descriptions and specifications of individual system components.

Equipment included

3082	Electrostatic Classifier Platform
3081A	Long DMA
3077A	Aerosol Neutralizer
3012	Aerosol Neutralizer
3074B	Filtered Air Supply
3076	Constant Output Atomizer
3062	Diffusion Dryer

Particle material

Solid or nonvolatile liquid

Particle size range

0.005 to 1 μm

Particle concentration

Adjustable from 0 to 10⁵ particles/cm³

Charger

Bipolar, Kr-85, 2 millicurie, half-life of 10.4 years*

Aerosol flow rate

0.2 to 3.5 L/min

Aerosol pressure range at classifier outlet

1 \pm 0.2 atm

Monodispersity

\pm 5% of mean size for singly charged particles

Compressed-air requirements

25 L/min at 35 psi

Specifications are subject to change without notice.

TSI and the TSI Logo are registered trademarks of TSI Incorporated.

*TSI is authorized by the United States Nuclear Regulatory Commission to distribute these neutralizers to customers in most countries. If your location is within the United States, no other federal license is required. Check local regulations for your own protection.

To Order

Submicrometer Monodisperse Aerosol Generation System

Specify	Description
3940A	Submicrometer Monodisperse Aerosol Generation System

Optional Accessories

Specify	Description
3001788	Conductive tubing, 1/4-inch inside diameter
3001789	Conductive tubing, 3/8-inch inside diameter
3068B	Aerosol Electrometer
3708	Flow Splitter
3772	Condensation Particle Counter*

*Other CPCs may be used



UNDERSTANDING, ACCELERATED

TSI Incorporated - Visit our website www.tsi.com for more information.

USA	Tel: +1 800 874 2811	India	Tel: +91 80 67877200
UK	Tel: +44 149 4 459200	China	Tel: +86 10 8219 7688
France	Tel: +33 1 41 19 21 99	Singapore	Tel: +65 6595 6388
Germany	Tel: +49 241 523030		



Distributed by:

Kenelec Scientific Pty Ltd
1300 73 22 33
sales@kenelec.com.au
www.kenelec.com.au