



RLY-8 Remote Relay Operation Manual

Rev C | 2019.08

www.critical-environment.com



ENVIRONMENTAL

Operating Temperature	-20°C to 40°C (-4°F to 104°F)
Humidity	15 to 90% non-condensing

CERTIFICATION

Model: RLY-8
S/N: RLY81603C00010
Rating: 24 VDC, 6W, Class 2



CERTIFIED FOR ELECTRIC SHOCK & ELECTRICAL FIRE HAZARD ONLY. LA CERTIFICATION ACNOR COUVRE UNIQUEMENT LES RISQUES DE CHOC ELECTRIQUE ET D'INCENDIE D'ORIGINE ELECTRIQUE.

Conforms to: CSA-C22.2 No. 205-12
UL508 (Edition 17):2007

Conforms to: EMC Directive 2004/108/EC
EN 50270:2006, Type 1, EN61010

Conforms to: FCC. This device complies with Part 15 of the FCC Rules. Operation is subject to the following two conditions: (1) This device may not cause harmful interference, and (2) this device must accept any interference received, including interference that may cause undesired operation.

INTRODUCTION

The RLY-8 is a remote relay device that offers an additional eight SPDT dry contact relays to a fixed gas detection system. The RLY-8 is designed to communicate with the FCS Flexible Control System and FCS-8 via Modbus® communications protocol. In the event that the connection is lost between the controller and the remote relay, a configurable default state can be set to ensure the relays continue to operate as required. The relays are rated 5 amps @ 240 VAC each and can be used to control remote alarms, strobes, exhaust fan starters, make up air fan contactors, or signaling other equipment like fire panels or alarm systems, etc.

The RLY-8 Remote Relay comes in a standard water / dust tight, corrosion resistant ABS / polycarbonate enclosure with a hinged, secured door.

A maximum of one (1) RLY-8 device (offering a maximum of eight (8) remote relays) can be connected to the FCS-8. Up to seven (7) RLY-8 devices (offering a maximum of fifty-six (56) remote relays) can be connected to the FCS-M or FCS-B.

Key Features

- » Increases the number of available relays
- » User selectable gas alarm activation level for each relay (set at the

Standard Enclosure Dimensions

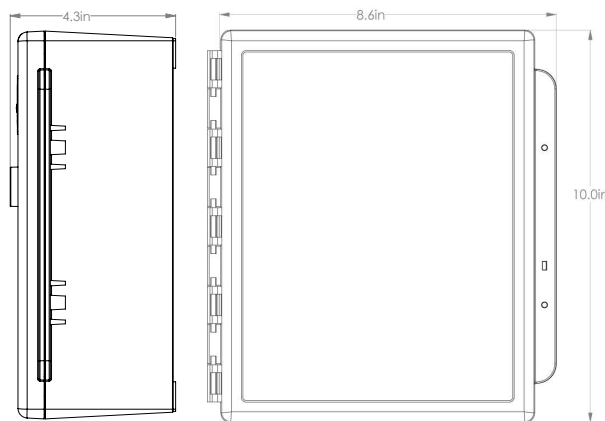

controller)

- » User selectable "Failsafe" and latching operation (set at the controller)
- » ON/OFF Delay configurations (set at the controller)
- » Configurable to revert to a default state if connection is lost with the controller (set at the controller)
- » Modbus® RS-485 RTU communication
- » Standard, dust / water tight, corrosion resistant enclosure (drip proof)

If after reading through this manual, you have any questions, please do not hesitate to contact our service department for technical support.

Critical Environment Technologies Canada Inc.

Unit 145, 7391 Vantage Way, Delta, BC V4G 1M3

Toll Free: +1.877.940.8741

Telephone: 604.940.8741

service@cetci.com

Fax: 604.940.8745

www.critical-environment.com

This product must be installed and inspected by a qualified electrician or factory trained technician. This instrument has not been designed to be intrinsically safe. For your safety, **do not** use it in classified hazardous areas (explosion-rated environments).

Exterior Enclosure - Front

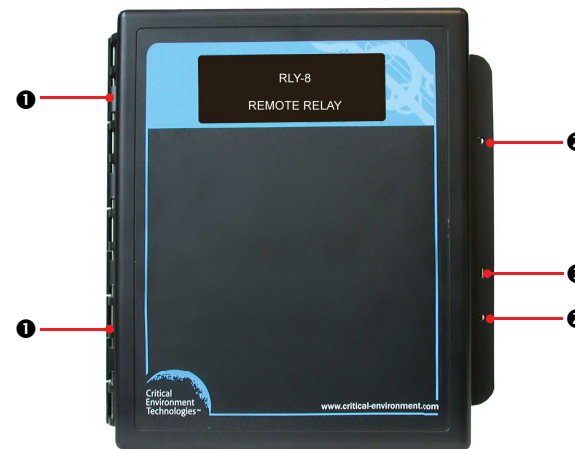

NUMBER	FEATURE	FUNCTION
1	Door Hinge	Secures door
2	Door Screw	Secures door
3	Padlock Opening	For security padlock

INSTRUMENT SPECIFICATIONS

Technical Specifications

MECHANICAL	
Enclosure	ABS / Polycarbonate. Copper coated interior to reduce RF interference.
Weight	1.24 kg (2.75 lbs)
Size	254 mm x 218 mm x 109 mm (10.0" x 8.6" x 4.3")
ELECTRICAL	
Power Requirements	24 VDC, 6W, Class 2 (draws power from the 24 VDC power supplied by the FCS)
Wiring	4-wire shielded in conduit network wiring between the devices
Fuses	Thermal, resetting
INPUT / OUTPUT	
Communication	Modbus® RTU over RS-485 Baud rate: 19,200 Modbus ID: 40 (default, configurable)
Relays	8 SPDT relays, rated 5 amps @ 240 VAC

Interior System Layout

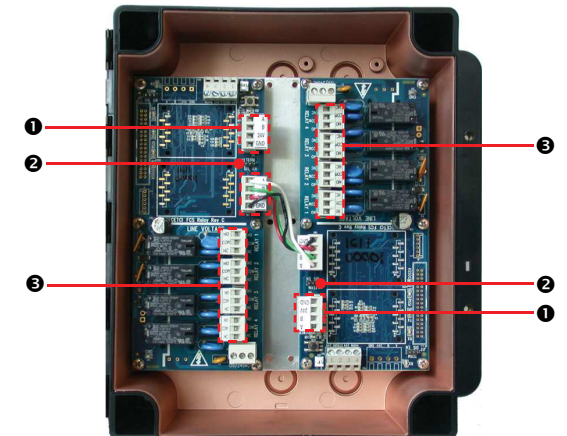

NUMBER	FEATURE	FUNCTION
1	LAN Terminals	Connections for Modbus® devices in the daisy chain network

②	LAN End of Line Jumper	120 ohm line termination
③	Relay Terminals	8 SPDT relays, rated 5 amps @ 240 V

Exterior Enclosure - Top/Bottom



NUMBER	FEATURE
①	Molded-in mounting bracket
②	1/2" Conduit Entry Knockouts

~9~

Interior Enclosure - Base

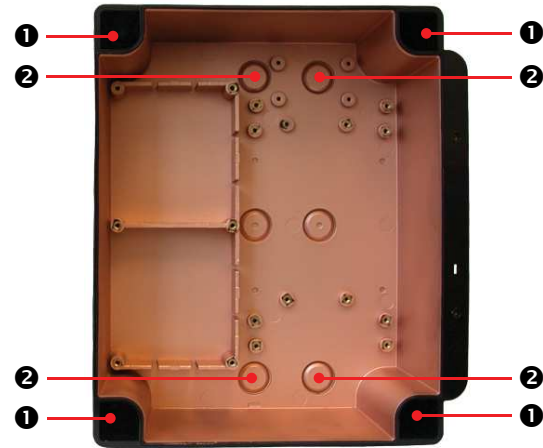

NUMBER	FEATURE
①	Mounting Holes
②	1/2" Conduit Entry Knockouts

~10~

INSTALLATION

The RLY-8 should be installed on a flat vertical surface using the four 4.4 mm (0.175") diameter mounting holes provided to maintain water tight status. There are ten available conduit entry points - three located along the top of the enclosure, three along the bottom and four are located on the back. These points may be drilled out as needed, with care taken not to damage the metal plate. **Do not use a conduit connector that has more than 12.7 mm (1/2") of thread length.**

NOTE: When mounting the enclosure, allow enough room for the door to fully open to access the wiring terminal.

The RLY-8 is intended for indoor use and should be protected from extreme weather conditions. It requires no assembly and virtually no maintenance other than ensuring that excess water (ie. condensation inside the conduit) or dust is not somehow entering the enclosure and physically damaging the circuit board or internal components. There are no serviceable or replaceable elements or components in this device.

WIRING CONNECTIONS

All wiring should be run within properly grounded (earth or safety) conduit. Signal output and supply should be in shielded cable. The cable shield should

~11~

be connected to earth ground.

Wiring Power Connections

The RLY-8 is a low voltage powered device. Any application of operating voltages higher than indicated in the specification may result in damage. Double check wiring connections prior to powering the RLY-8. Damage from incorrect wiring connections or from too much voltage applied is not covered under warranty.

The wiring should be 4-conductor shielded 16 awg stranded and run within properly grounded (earth or safety) conduit. Building code requires low voltage wiring not to be within the same conduit as line voltage wiring.

NOTE: WARRANTY VOID IF SOLID-CORE WIRE IS USED AT THE WIRING TERMINAL STRIP. When using solid core wiring for distribution (in the conduit), use stranded wire pigtails 18 AWG within the enclosure to connect to the circuit board. The rigidity of solid-core wire can pull a soldered terminal strip completely off a circuit board and this will not be covered under warranty.

~12~

4-Wire 24 VDC Wiring Connection

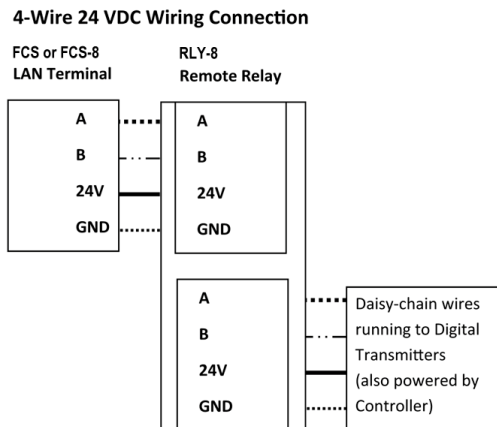

The RLY-8 can be wired directly to the FCS or FCS-8 followed by digital transmitters connected in a daisy-chain configuration. Or it can be wired anywhere along the digital network in a daisy-chain configuration as required.

~13~

RELAY CONNECTIONS

The relays are SPDT (single pole, double throw) thereby each relay provides one set of usable dry contacts. The relays are programmable for Alarm Levels and/or Faults (at the controller).

Because all CETCI fixed gas detection systems are designed to be fail-safe, **the relay coils are normally energized in non-alarm state for failsafe operation.** If required, the relays can be configured for normal Relay operation. Refer to the Operation Manual of the FCS for more information.

~14~

Relay Wiring Connection Example

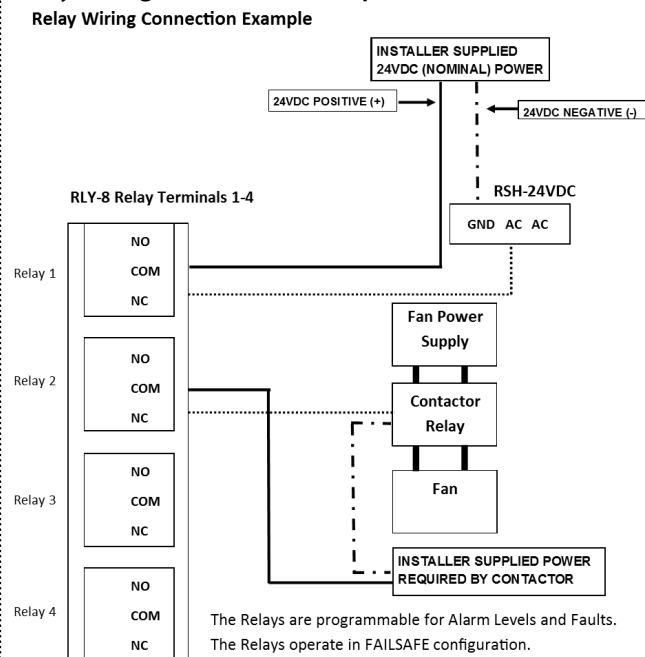

~15~



Distributed by:
Kenelec Scientific Pty Ltd
1300 73 22 33
sales@kenelec.com.au
www.kenelec.com.au