

*Critical Environment Technologies  
Canada Inc.*

# YESAIR

*Next Generation, Indoor Air Quality  
Information Monitoring & Recording  
Instrument*



## OPERATION MANUAL

REV: H JANUARY-15-2011  
For Instrument Firmware Version: 3.0 & up

#145, 7391 Vantage Way  
Delta, BC V4G 1M3 Canada  
Phone: 877-940-8741 \* [www.critical-environment.com](http://www.critical-environment.com)



# **Critical Environment Technologies Canada Inc.**

**Address:**

#145, 7391 Vantage Way  
Delta, BC V4G 1M3

**Phone Numbers:**

604-940-8741  
877-940-8741 (toll free)

**Fax Number:**

604-940-8745

**Website:**

[www.critical-environment.com](http://www.critical-environment.com)

**Service Centers:**

**Canada**

#145, 7391 Vantage Way  
Delta, BC V4G 1M3

## IMPORTANT NOTE

READ AND UNDERSTAND THIS MANUAL PRIOR TO USING THIS INSTRUMENT. CAREFULLY READ THE WARRANTY POLICY, SERVICE POLICY, NOTICES, DISCLAIMERS AND REVISIONS ON THE FOLLOWING PAGES.

THIS INSTRUMENT SHOULD BE INSPECTED AND CALIBRATED REGULARLY BY A QUALIFIED AND TRAINED TECHNICIAN.

THIS INSTRUMENT HAS NOT BEEN DESIGNED TO BE INTRINSICALLY SAFE. FOR YOUR SAFETY, **DO NOT** USE IT IN CLASSIFIED HAZARDOUS AREAS (EXPLOSION-RATED ENVIRONMENTS).

**INSTRUMENT SERIAL NUMBER:**

---

**PURCHASE DATE:**

---

**PURCHASED FROM:**

---

## WARRANTY POLICY

CRITICAL ENVIRONMENT TECHNOLOGIES CANADA INC. (THE MANUFACTURER) WARRANTS THIS INSTRUMENT TO BE FREE FROM DEFECTS IN MATERIALS AND WORKMANSHIP FOR A PERIOD OF TWO YEARS, EXCLUDING SENSORS, FROM THE DATE OF PURCHASE BY THE ORIGINAL OWNER. THE SENSORS HAVE A WARRANTY PERIOD OF ONE YEAR FROM THE DATE OF PURCHASE. IF THE PRODUCT SHOULD BECOME DEFECTIVE WITHIN THIS WARRANTY PERIOD, WE WILL REPAIR OR REPLACE, IT AT OUR DISCRETION.

THE WARRANTY STATUS MAY BE AFFECTED IF THE INSTRUMENT HAS NOT BEEN USED AND MAINTAINED AS PER THE INSTRUCTIONS IN THIS MANUAL OR HAS BEEN ABUSED, DAMAGED OR MODIFIED IN ANY WAY. THIS INSTRUMENT IS ONLY TO BE USED FOR PURPOSES STATED HEREIN. THE MANUFACTURER IS NOT LIABLE FOR AUXILIARY INTERFACED EQUIPMENT OR CONSEQUENTIAL DAMAGE.

DUE TO ONGOING RESEARCH, DEVELOPMENT AND PRODUCT TESTING, THE MANUFACTURER RESERVES THE RIGHT TO CHANGE SPECIFICATIONS WITHOUT NOTICE. THE INFORMATION CONTAINED HEREIN IS BASED ON DATA CONSIDERED ACCURATE. HOWEVER, NO WARRANTY IS EXPRESSED OR IMPLIED REGARDING THE ACCURACY OF THIS DATA.

ALL GOODS MUST BE SHIPPED TO THE MANUFACTURER BY PREPAID FREIGHT. ALL RETURNED GOODS MUST BE PRE-AUTHORIZED BY OBTAINING A RETURN MERCHANDISE AUTHORIZATION (RMA) NUMBER. CONTACT THE MANUFACTURER FOR A NUMBER AND PROCEDURES REQUIRED FOR PRODUCT TRANSPORT.

## **SERVICE POLICY**

CRITICAL ENVIRONMENT TECHNOLOGIES CANADA INC. (CETCI) MAINTAINS AN INSTRUMENT SERVICE FACILITY AT THE FACTORY. SOME CETCI DISTRIBUTORS / AGENTS MAY ALSO HAVE REPAIR FACILITIES, HOWEVER, CETCI ASSUMES NO LIABILITY FOR SERVICE PERFORMED BY ANYONE OTHER THAN CETCI PERSONNEL. REPAIRS ARE WARRANTED FOR 90 DAYS AFTER DATE OF SHIPMENT (SENSORS, PUMPS, FILTERS AND BATTERIES HAVE INDIVIDUAL WARRANTIES). SHOULD YOUR INSTRUMENT REQUIRE NON-WARRANTY REPAIR, YOU MAY CONTACT THE DISTRIBUTOR FROM WHOM IT WAS PURCHASED OR YOU MAY CONTACT CETCI DIRECTLY.

IF CETCI IS TO DO THE REPAIR WORK, YOU MAY SEND THE INSTRUMENT, PREPAID, TO THE ADDRESS LISTED ON PAGE-3 , ATTENTION: SERVICE DEPARTMENT. ALWAYS INCLUDE YOUR RMA #, ADDRESS, TELEPHONE NUMBER, CONTACT NAME, SHIPPING / BILLING INFORMATION AND A DESCRIPTION OF THE DEFECT AS YOU PERCEIVE IT. YOU WILL BE CONTACTED WITH A COST ESTIMATE FOR EXPECTED REPAIRS, PRIOR TO THE PERFORMANCE OF ANY SERVICE WORK. FOR LIABILITY REASONS, CETCI HAS A POLICY OF PERFORMING ALL NEEDED REPAIRS TO RESTORE THE INSTRUMENT TO FULL OPERATING CONDITION.

PRIOR TO SHIPPING EQUIPMENT TO CETCI, CONTACT OUR OFFICE FOR AN RMA # (RETURNED MERCHANDISE AUTHORIZATION). ALL RETURNED GOODS MUST BE ACCOMPANIED WITH AN RMA NUMBER.

PACK THE EQUIPMENT WELL (IN IT'S ORIGINAL PACKING IF POSSIBLE), AS WE CANNOT BE HELD RESPONSIBLE FOR ANY DAMAGE INCURRED DURING SHIPPING TO OUR FACILITY.

## **NOTICES**

COPYRIGHTS: THIS MANUAL IS SUBJECT TO COPYRIGHT PROTECTION; ALL RIGHTS ARE RESERVED. UNDER INTERNATIONAL AND DOMESTIC COPYRIGHT LAWS, THIS MANUAL MAY NOT BE COPIED OR TRANSLATED, IN WHOLE OR IN PART, IN ANY MANNER OR FORMAT, WITHOUT THE WRITTEN PERMISSION OF CRITICAL ENVIRONMENT TECHNOLOGIES CANADA INC.

ALL SOFTWARE WHICH CETCI UTILIZES AND/OR DISTRIBUTES, HOLDS A PROPRIETARY INTEREST AND IS ALSO SUBJECT TO COPYRIGHT PROTECTION AND ALL RIGHTS ARE RESERVED. NO PARTY MAY USE OR COPY SUCH SOFTWARE IN ANY MANNER OR FORMAT, EXCEPT TO THE EXTENT THAT CETCI GRANTS THEM A LICENSE TO DO SO. IF THIS SOFTWARE IS BEING LOADED ONTO MORE THAN ONE COMPUTER, EXTRA SOFTWARE LICENSES MUST BE PURCHASED.

REFERENCE IMPORTANT NOTES ON PAGES: 3, 18,

## **DISCLAIMER**

**UNDER NO CIRCUMSTANCES WILL CRITICAL ENVIRONMENT TECHNOLOGIES CANADA INC. BE LIABLE FOR ANY CLAIMS, LOSSES OR DAMAGES RESULTING FROM OR ARISING OUT OF THE REPAIR OR MODIFICATION OF THIS EQUIPMENT BY A PARTY OTHER THAN CETCI SERVICE TECHNICIANS, OR BY OPERATION OR USE OF THE EQUIPMENT OTHER THAN IN ACCORDANCE WITH THE PRINTED INSTRUCTIONS CONTAINED WITHIN THIS MANUAL OR IF THE EQUIPMENT HAS BEEN IMPROPERLY MAINTAINED OR SUBJECTED TO NEGLIGENCE OR ACCIDENT. ANY OF THE FOREGOING WILL VOID THE WARRANTY.**

## **REVISIONS**

THIS MANUAL WAS WRITTEN AND PUBLISHED BY CRITICAL ENVIRONMENT TECHNOLOGIES CANADA INC. (THE MANUFACTURER). THE MANUFACTURER MAKES NO WARRANTY OR REPRESENTATION, EXPRESSED OR IMPLIED INCLUDING ANY WARRANTY OF MERCHANTABILITY OR FITNESS FOR PURPOSE, WITH RESPECT TO THIS MANUAL. ALL INFORMATION CONTAINED IN THIS MANUAL IS BELIEVED TO BE TRUE AND ACCURATE AT THE TIME OF PRINTING. HOWEVER, AS PART OF IT'S CONTINUING EFFORTS TO IMPROVE IT'S PRODUCTS AND THEIR DOCUMENTATION, THE MANUFACTURER RESERVES THE RIGHT TO MAKE CHANGES AT ANY TIME WITHOUT NOTICE. REVISED COPIES OF THIS MANUAL CAN BE OBTAINED BY CONTACTING THE MANUFACTURER.

SHOULD YOU DETECT ANY ERROR OR OMISSION IN THIS MANUAL, PLEASE CONTACT THE COMPANY AT THE FOLLOWING ADDRESS:

CRITICAL ENVIRONMENT TECHNOLOGIES CANADA INC.  
#145, 7391 VANTAGE WAY  
DELTA, BC V4G 1M3  
CANADA

TOLL FREE: 1-800-940-8741  
PHONE: 1-604-940-8741  
FAX: 1-604-940-8745  
WEBSITE: [WWW.CRITICAL-ENVIRONMENT.COM](http://WWW.CRITICAL-ENVIRONMENT.COM)

IN NO EVENT WILL CRITICAL ENVIRONMENT TECHNOLOGIES CANADA INC., OR IT'S OFFICERS OR EMPLOYEES BE LIABLE FOR ANY DIRECT, SPECIAL, INCIDENTAL OR CONSEQUENTIAL DAMAGES RESULTING FROM ANY DEFECT IN ANY MANUAL, EVEN IF ADVISED OF THE POSSIBILITY OF SUCH DAMAGES.

**PRINTED IN CANADA**  
**Revision: G-300409**

# INDEX

<u>SECTION</u>	<u>DESCRIPTION</u>	<u>PAGE</u>
	IMPORTANT NOTE AND WARRANTY POLICY	4
	SERVICE POLICY AND NOTICES	5
	DISCLAIMER AND REVISIONS	6
	INDEX	7-8
	WELCOME	9
	YESAIR SHIPPING CHECK LIST	10
1.0	GENERAL	11
2.0	SPECIFICATIONS	11-13
2.1	SENSOR CONFIGURATION NOTES	14
2.2	INSTRUMENT KEY FEATURES	14
2.3	DIFFUSION VERSION SENSOR CAP PHOTO	14
2.4	DESCRIPTION FRONT & BOTTOM VIEW	15
2.4	DESCRIPTION LEFT SIDE VIEW	16
2.5	DESCRIPTION TOP & REAR VIEW	17
3.0	ENCLOSURE DIMENSIONS	18
4.0	INSTRUMENT OPERATION	19
	BUTTON PRESSING	19
	SECURITY CODE	19
4.1	SWITCHING INSTRUMENT ON/OFF	19
4.2	BATTERY & "BATTERY WARNING"	19-20
4.3	MAIN MENU FUNCTIONS	20-21
5.0	MENU FUNCTION DETAILS	21-25
	CALIBRATE	21-22
	FREQUENCY	22
	SETTINGS	22-24
	SENSORS	22-23
	BATTERY	23

## INDEX

<u>SECTION</u>	<u>DESCRIPTION</u>	<u>PAGE</u>
	SETTINGS, CONT'D	22-24
	KEYPAD	23
	DISPLAY	24
	PUMP	24
	PASSCODE	24
	DEFAULT	24
	DATALOG	24-26
	DEFAULT	24
	SET UP	24-25
	ACTIVATE	25
	STOP LOG	25
	LOCATION	26
	MEM CARD	26
	ALARM	26-27
	INFO	28
	USB	28
6.0	CALIBRATION PROCEDURE	28-32
7.0	ADDING OR CHANGING PLUG & PLAY SENSORS	32-34
8.0	INFORMATION RECORDING OPERATION	34
9.0	MAINTENANCE	34
10.0	YESAIR TROUBLE SHOOTING	35
11.0	ACCESSORIES	36-37
	EXTENDED OPERATION BATTERIES	37

## WELCOME

Thank you for purchasing our YESAIR multi-sensor, air quality monitor and information recording instrument. The YESAIR series of instruments are easy to use, portable, monitoring and information recording devices for monitoring trends that pertain to indoor air quality.

YESAIR is equipped with top mounted temperature and relative humidity sensors to aid in verifying readings providing a comprehensive indication of air quality. Information readings are written to a plug-in flash card providing bullet-proof memory to protect your recorded information. The sample rate can be adjusted using the supplied software or through the instrument menu. The instrument may be hand-held, will easily stand on a flat surface, or fastened to a wall for permanent or semi-permanent use.

YESAIR series of instruments are manufactured with plug-and-play, interchangeable sensor modules to allow for multiple gas testing. The specifications listed in this manual indicate a wide array of sensors to choose from. These sensors may be changed in the field and operated within minutes (accurate readings will require more time as each sensor type has different warm up / stabilization periods before they are able to perform to published specifications).

Calibration and repair is available at our manufacturing facility and through some of our authorized and trained distributors.

YESAIR can reliably record time-based information, which can be downloaded via the USB port located on the right side of the instrument. Any computer capable of running Microsoft Windows 2000 or higher (with an available USB communications port) can accommodate the YES VIEWER terminal software.

If after reading through the manual, you have any questions, please do not hesitate to contact our service department for technical support.



## YESAIR SHIPPING CHECKLIST

This checklist ensures that you have received everything required to run your IAQ monitor / logger. If you do not receive any of the items listed below, contact the factory immediately:

- YESAIR multi-gas monitor/logger
- AC wall adapter 6V @ 850 mA
- Nickel-metal Hydride rechargeable batteries (3 X "AA")
- Calibration/probe fitting
- Operation manual
- YES VIEWER terminal data logging software (option)
- Communications cable (option)
- Other specified accessories (please refer to original sales order and the comments below):

---

---

---

---

---

---

---

---

---

---

Date: \_\_\_\_\_

Checked by: \_\_\_\_\_

## 1.0 GENERAL

YESAIR is a battery powered, portable indoor air quality monitor - information recording (data logging) instrument designed for intermittent or continuous operation. It's intended use is for indoor environments. A basic instrument includes a multi-line LCD alpha numeric display, audible alarm, rechargeable batteries, Temperature and Relative Humidity sensors, operation manual.

The user can add up to five additional plug-and-play sensors (electrochemical toxic gas and/or Oxygen, Infrared CO<sub>2</sub>, PID or Catalytic combustible/flammable gas) internally for a maximum of seven internal sensors. Currently, a selection of up to twenty-seven different sensors are available to choose from. Reference the list of available sensors on next page.

## 2.0 SPECIFICATIONS

Enclosure:	<p>a) Dimensions: 7" (178 mm) Wide X 8.4" (213 mm) High X 2.2" (56 mm) Deep</p> <p>b) Weight: 18 ounces (524 grams)</p> <p>Features: * Removable sensor cover * Removable battery cover (bottom of enclosure) * Threaded insert (bottom of enclosure) to accommodate a camera tripod * Slot for cable lock (right side bottom) * Slot at the upper rear to allow instrument to hang on a wall * Openings at front top left for audible sounder</p>
Construction:	Custom molded, rugged, contoured ABS/Polycarbonate UL94 rating
Power:	<p>Standard: Rechargeable NiMH batteries X three</p> <p>* <b>Note:</b> A "protection diode" in the circuit provides safety protection when the batteries are accidentally inserted with reversed polarity</p> <p>* <u>Option:</u> User can install three "AA" alkaline batteries. See section 4.2 of this manual for more detail.</p> <p>* Continuous: Plug-in, 6VDC, class-III, 2A dc max. wall adapter</p>
Visual:	Back-lit, multi-line LCD alphanumeric display 3-tactile push-buttons for user access
Monitoring Mode:	<p>Internal, automatic sample pump for "Active" sampling of target environment</p> <p>Optional: Diffusion monitoring version</p>
Circuit:	Microprocessor, user configurable

## 2.0 SPECIFICATIONS

Operating Ranges:	Temperature: 5 to 50 degrees C (41 to 122 degrees F) Relative Humidity: 0 to 99% RH non-condensing
Storage Ranges:	Temperature: -20 to +60 degrees C (-4 to +140 degrees F) Relative Humidity: 0 to 99% RH non-condensing
Certifications:	CE standards for safety: I.S. EN61010-1:2001 (Ed.2) CE standards for emissions: EN 50270:2006 CE standards for immunity: EN 50270:2006
Usage:	The YESAIR is a portable, battery powered instrument designed for hand-held use. <u>Other uses include:</u> <b>1)</b> mounting on a standard camera tripod via the threaded brass fitting molded into the base of the instrument (reference photo on page-13, section 2.3). <b>2)</b> Wall mounting via the slot of upper rear portion of the instrument enclosure. (reference photo on page-15, section 2.5). <b>3)</b> Instrument will easily accommodate sitting on a flat surface such as a desk top.

### Minimum System Requirements to Operate Datalog Recording Software:

- \* Personal computer with Pentium III class processor or better
- \* 512MB RAM (minimum), VISTA compatible
- \* A hard disk with at least 1 MB of available disk space. Additional space is required to store logger files and graph files
- \* An available USB port

### SENSORS (PLUG & PLAY) AVAILABLE FOR YESAIR

SENSOR	STANDARD MEASUREMENT RANGE
Carbon Dioxide (CO <sub>2</sub> )	0 - 5000 ppm
Carbon Dioxide (CO <sub>2</sub> )	0 - 10,000 ppm
Carbon Dioxide (CO <sub>2</sub> )	0 - 5% volume
Carbon Dioxide (CO <sub>2</sub> )	0 - 20% volume
Carbon Dioxide (CO <sub>2</sub> )	0-100% volume
Carbon Monoxide (CO)	0 - 50 ppm
Nitrogen Dioxide (NO <sub>2</sub> )	0 - 5.0 ppm
Nitric oxide (NO)	0 - 100 ppm

## 2.0 SPECIFICATIONS

### SENSORS (PLUG & PLAY) AVAILABLE FOR YESAIR

SENSOR	STANDARD MEASUREMENT RANGE
Combustible gases/vapours	0 - 100% LEL
Oxygen (O <sub>2</sub> )	0 - 25.0% volume
Ozone (O <sub>3</sub> )	0 - 1.00 ppm
Ammonia (NH <sub>3</sub> )	0 - 50 ppm
Chlorine (Cl <sub>2</sub> )	0 - 5.0 ppm
Chlorine Dioxide (ClO <sub>2</sub> )	0 - 1.0 ppm
Hydrogen (H <sub>2</sub> )	0 - 1000 ppm
Hydrogen Sulphide (H <sub>2</sub> S)	0 - 50 ppm
Hydrogen Chloride (HCl)	0 - 30 ppm
Hydrogen Cyanide (HCN)	0 - 100 ppm
Hydrogen Fluoride (HF)	0 - 10 ppm
Sulphur Dioxide (SO <sub>2</sub> )	0 - 20 ppm
Formaldehyde (HCHO)	0 - 10 ppm
Arsine (AsH <sub>3</sub> )	0 - 2.0 ppm
Flourine (F <sub>2</sub> )	0 - 2.0 ppm
Phosphine (PH <sub>3</sub> )	0 - 1.0 ppm
Silane (SiH <sub>4</sub> )	0 - 1.0 ppm
Total Volatile Organic Compounds (TVOC)	0 - 300 ppm
Total Volatile Organic Compounds (TVOC)	0 - 2000 ppm
Total Volatile Organic Compounds (TVOC)	0 - 50 ppm
Total Volatile Organic Compounds (TVOC)	0 - 20 ppm

**NOTE-1:** Not all of the above sensors are available from stock. Delivery time for sensors ordered will vary depending on which sensors are ordered, how many are ordered and measurement range desired.

**NOTE-2:** Other measurement ranges are available for some sensors. Contact factory with desired range to confirm availability.

**NOTE-3:** Some of these sensors must be calibrated with correlation gases because they are more readily available. If the customer wishes them to be calibrated with the exact target gas, extra charges will apply to acquire the specific gas if and when available. In these cases, customer will be required to take delivery of the special cylinder of span gas and dangerous goods and shipping costs will apply.

**NOTE-4:** Some of the above sensors have cross sensitivities to other gases (interfering gases). Please refer to the sensor specification chart before ordering a specific sensor if your application may have some of the interfering gases present.

## 2.1 SENSOR CONFIGURATION NOTES, ***IMPORTANT***

It is important to note that although the YESAIR will accommodate seven sensors and five of those sensor locations are plug and play for gas sensors, there are sensor placement considerations. Either of the two front sensor locations will accommodate an infrared CO2 sensor, PID sensor or catalytic combustible (flammable) gas sensor.

Of the five plug and play sensor locations, three are for electrochemical sensors. If the user selects an Oxygen (O2) sensor, it must be fitted to a specific sensor location (rear center position, determined by looking at the front of the instrument). If the user selects a Nitric Oxide (NO), requiring electronic bias within the circuit, it must be fitted to one specific sensor location (left rear position, determined by looking at the front of the instrument). Two sensors requiring bias cannot be fitted in the same instrument at the same time. Reference the photo reference on page-33 for specific sensor locations.

## 2.2 INSTRUMENT KEY FEATURES

- \* Light weight, contoured and comfortable to hold
- \* Flame rated ABS/Polycarbonate enclosure
- \* Displays all installed sensors simultaneously on backlit LCD display
- \* Multi-function, easy to use menu
- \* Operates from nickel metal hydride (NiMH) rechargeable batteries (standard), or alkaline batteries or continuously from the plug-in power adapter
- \* Hangs on a wall (rear slot molded in), mounts on a camera tripod or sits on a desk
- \* Accommodates a standard cable lock for securing the instrument in place
- \* Samples air with internal sample draw pump
- \* Accommodates electrochemical, catalytic, PID or infrared sensor types
- \* Thirty different plug & play sensors available to choose from
- \* Logs information and events to small camera flash card (2GB)
- \* USB data downloading and auxiliary up loading from remote probes
- \* XP, VISTA & Windows-7 compatible

## 2.3 DIFFUSION VERSION SENSOR CAP PHOTO

Note: This version is NOT supplied with an internal pump. Sensors “breathe” through openings in sensor chamber cap. Response time is very good for most gases.



## 2.4 DESCRIPTION FRONT & BOTTOM VIEW PHOTO



## 2.5 DESCRIPTION LEFT SIDE VIEW

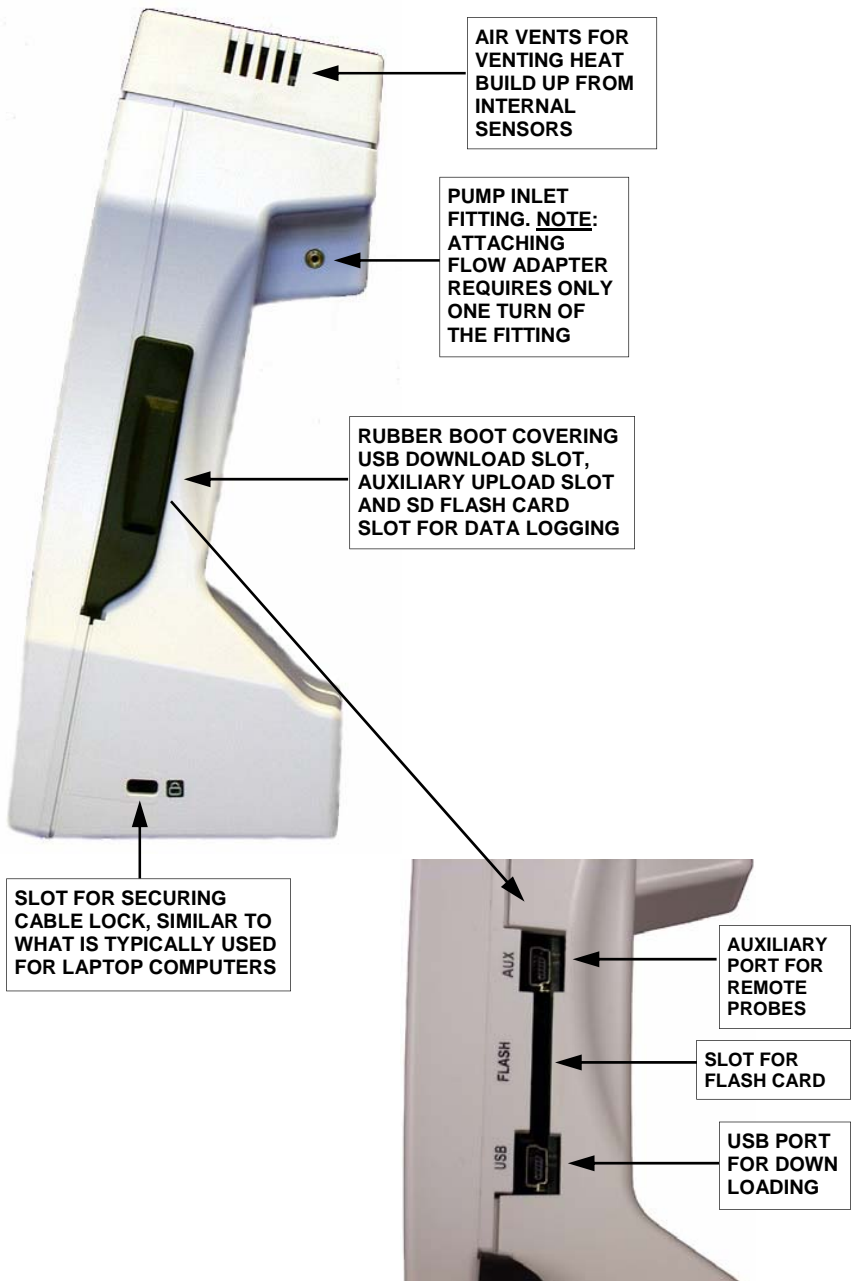

## 2.6 DESCRIPTION REAR & TOP VIEW

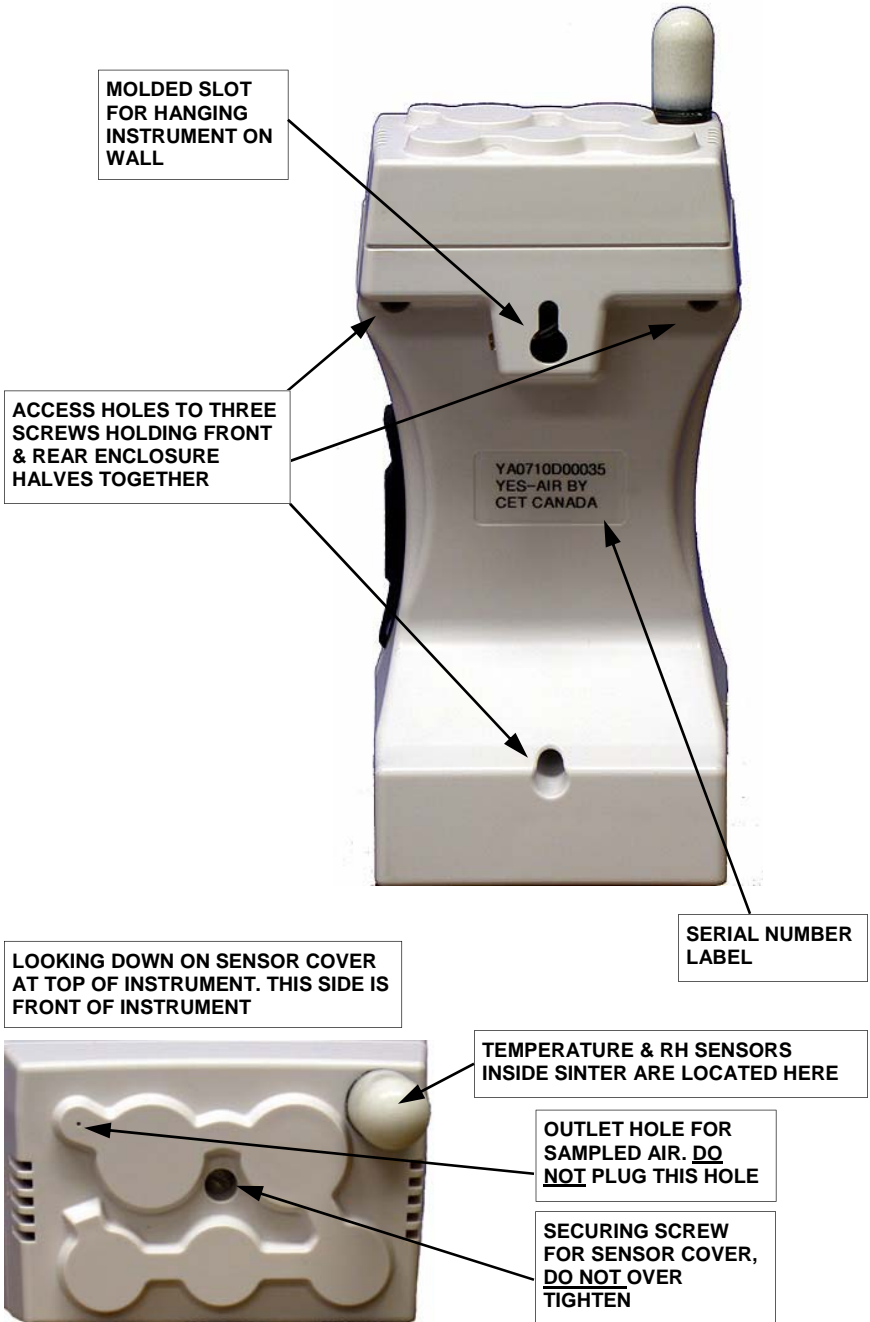

### 3.0 ENCLOSURE DIMENSIONS PHOTOGRAPH



## 4.0 INSTRUMENT OPERATION

The YESAIR has an extensive menu system allowing the user to access a wide range of features and functionality. All features and functions can be set to meet the user's specific requirements.

**BUTTON PRESSING:** The three membrane push-buttons on the front face of the instrument should be pressed firmly and slowly. They have been designed such that an accidental light touch does not register and change something the user may be working on.

**SECURITY CODE:** Some functions within the menu system are protected by a security code to prevent unauthorized or untrained personnel from accessing them and changing critical values within the instrument that might produce incorrect or unsafe readings. All YESAIR instruments are shipped from the factory with a generic security code of "1, 2, 3, 4". It is recommended the user change this to a code known only to authorized personnel.

### 4.1 SWITCHING INSTRUMENT ON / OFF

***IMPORTANT NOTE: WHEN USING PUSH-BUTTONS ON FRONT OF INSTRUMENT ENCLOSURE, PRESS FIRMLY AND WATCH THE DISPLAY FOR MOVEMENT. A LIGHT FINGER PRESS WILL NOT ENGAGE THE DOMED CONTACT. THIS IS TO PREVENT ACCIDENTAL CHANGES TO MENU.***

**SWITCH ON:** Press "MENU" button down momentarily then release. The multi-line LCD will scroll through each of the information functions as it warms up.

**SWITCH OFF:** Hold "MENU" button down for five to six seconds then release. The multi-line LCD will indicate "Shutting monitor off".

Upon switch on, the LCD display indicates "**YESAIR, PORTABLE AIR QUALITY MONITOR**", then "**WARMING UP UNIT PLEASE WAIT...**" and the inner sample draw pump starts automatically sampling the environment. A symbol at the bottom left corner of the display will indicate if the instrument is operating from batteries or the plug-in wall adapter. After warm up period (approximately 3-minutes), the LCD indicates all installed sensors and their current, real time readings and the cursor flashes.

**NOTE-1:** More accurate real-time readings will occur after the sensors have warmed up and stabilized a little longer.

**NOTE-2:** Warm-up can be skipped by holding the MENU button for 3-5 seconds

### 4.2 BATTERY & BATTERY WARNINGS

The YESAIR operates from three different power sources. Rechargeable Nickel Metal Hydride NiMH) batteries (3 X "AA"), disposable Alkaline batteries (3 X "AA") or plug-in wall adapter/battery charger. Reference page-11, section 2.0 for specifications. The YESAIR is supplied with and configured for rechargeable batteries from the factory.

**CAUTION:** If the user wishes to change from one type of battery to another (eg. Rechargeable to Alkaline), they must first make the change through the instrument menu.

## 4.0 INSTRUMENT OPERATION

### 4.2 BATTERY & BATTERY WARNINGS

**NOTE-1:** The battery tabs are such that even if batteries are installed by accident with reverse polarity, no damage will occur. Always take care when installing any kind of battery.

**NOTE-2:** Instrument will not charge the NiMH batteries unless the instrument is switched off.

**NOTE-3:** A YELLOW WARNING LABEL HAS BEEN PLACED ON THE BATTERY DOOR OF THE YESAIR. THIS IS TO ALERT THE USER TO THE FACT THAT IF ALKALINE BATTERIES ARE INSTALLED BY MISTAKE AND THE USER ATTEMPTS TO RECHARGE THEM WITH THE SUPPLIED WALL ADAPTER, DAMAGE COULD OCCUR. RECHARGING ALKALINE BATTERIES COULD CAUSE THEM TO LEAK THUS CREATING POTENTIAL HARM AND/OR PHYSICAL DAMAGE TO THE INSTRUMENT. DAMAGE CAUSED BY THIS TYPE OF ACTION IS NOT COVERED UNDER WARRANTY AND THE MANUFACTURER IS NOT RESPONSIBLE.

### 4.3 MAIN MENU FUNCTIONS

Pressing the MENU button after the main sensor array is displayed allows the user to enter the extensive menu system. The first menu display includes:

**PREVIOUS**  
**CALIBRATE**  
**SETTINGS**  
**DATALOG**  
**ALARM**  
**INFO**  
**USB**

**NOTE:** In all cases, use the ARROW DOWN or ARROW UP buttons to scroll through any displayed menu and use the MENU button to select any highlighted choices.

**PREVIOUS:** Allows the user to go back to the previous function. Pressing the MENU button repeatedly at "PREVIOUS" will step the user back one menu at a time until you finally reach the main sensor real-time display. Alternatively, hold down the MENU button for approximately 6 to 7 seconds and the LCD will jump back to the main, real-time sensor display.

**CALIBRATE:** Allows the user to enter the calibration section of the menu. This section is protected by a security code to prevent unauthorized people from attempting to calibrate the sensors. Reference pages 28-32 for the calibration procedure.

**SETTINGS:** This menu item provides the user with a number of instrument functions that can be set or modified to suit their personal use.

**DATALOG:** This menu item allows the user to set up the internal data logger to suit their specific application. This function can also be achieved with the instrument connected to a computer. Set up and programming through a pc is faster but the YES VIEWER data logging function can be completely set up through the menu in the instrument.

## 4.0 INSTRUMENT OPERATION

### 4.3 MAIN MENU FUNCTIONS

**ALARM:** This menu item allows the user to set the alarm levels as well as which alarms are activated.

**INFO:** Provides the user with information on the instrument such as serial number assigned and date of manufacture. It also provides the user with information on the installed sensors such as sensor serial number, date code, and calibration date information.

**USB:** Allows the user to reset the USB chip if the YESAIR will not communicate with "YES VIEWER" software.

### 5.0 MENU FUNCTION DETAILS

**CALIBRATE:** Pressing the MENU button at this menu function puts the user into the calibration section of the menu. The LCD immediately indicates "**ENTER SECURITY CODE**". The user must input a 4-digit security code to access the calibration menu. This prevents unauthorized users from tampering with the calibration settings. All YESAIR instruments are shipped from the factory with a generic security code setting of "1234". The user can easily change this code setting for extra security. Reference page-22 of this manual.

**NOTE:** If the wrong security code has been entered, the display indicates "INVALID SECURITY CODE ENTERED" and the display flips back to the menu list.

The calibration menu provides the user with two main functions to calibrate all gas sensors, SPAN and ZERO. Both of these functions are required as part of the regular instrument maintenance to achieve "best performance" from the sensors. **Zero function must be performed before the span function.**

PID sensors for TVOCs (Total Volatile Organic Compounds) should be calibrated *every three months* for best performance. This sensor measures the "total" response from all VOCs in the target area and cannot identify individual gases or chemicals.

Infrared CO<sub>2</sub> sensors should be calibrated *yearly* for best performance.

Electrochemical, toxic gas sensors should be calibrated *every six months* for best performance.

Catalytic, combustible gas sensors should be calibrated *every six months* for best performance.

Both zero and span functions are automated. Before span adjusting the sensor, the user must first tell the YESAIR what concentration of span gas is being used to span each sensor. This does not apply to temperature, RH or Oxygen sensors. Temperature and RH sensors must be calibrated using a controlled environment such as a chamber. With Oxygen sensors, it is assumed you will use the environment around you because it contains approximately 20.9% O<sub>2</sub>. After that, push the menu button over the zero or span selection and follow the instructions on the LCD.

## 5.0 MENU FUNCTION DETAILS

### CALIBRATE

**NOTE:** For more information on calibration function, see calibration section-6.0, page 27 of this manual.

**CALIBRATION FREQUENCY:** The frequency of calibration maintenance to expect best performance from installed sensors. Temperature and Relative humidity sensors should be calibrated once per year. All other toxic and combustible gas sensors should be calibrated once every six months for best performance and to meet published specifications.

**SETTINGS:** This menu item provides the user with the ability to configure much of the instrument functionality to suit their specific needs. Use the ARROW DOWN button to scroll to "**SETTINGS**" then push the MENU button to enter this menu and view the listed functions. Use the ARROW DOWN button to scroll to the function you wish to change and press the MENU button.

The functions available for modification are:

**PREVIOUS  
SENSORS  
BATTERY  
KEYPAD  
DISPLAY  
PUMP  
PASS CODE  
DEFAULT**

**SENSORS:** This menu lists only the installed sensors that provide the user with the ability to adjust them from the menu. The choices are:

**TEMP  
RH  
VOC (TVOCs)**

**TEMP:** The options available are:

**DEGREES C  
DEGREES F  
ADJUST**

This menu item allows the user to change the temperature unit from degrees C to degrees F or visa versa. The second function allows the user to adjust the temperature value slightly to align it with another device. The third function allows the user to adjust the RH value slightly to align with another device. The choice is -1% or +1% RH.

## 5.0 MENU FUNCTION DETAILS

### SETTINGS, SENSORS

**Temperature adjust:** This menu allows the user to “tweak” the displayed temperature value slightly (+/-1 degree C or +/- 2 degrees F). This function can only be used once to prevent excessive adjustment of temperature sensor without the use of a calibration chamber. Using the ARROW DOWN button, scroll to “ADJUST” and press the MENU button. The LCD will ask the user to input the desired numeric value. Once the last digit has been entered, the new temperature value will be automatically saved.

**RH adjust:** Use the ARROW DOWN button to scroll to the desired choice and push the MENU button.

**VOC:** This menu allows the user to switch the units of measure for the PID sensor only. The choices are: “PPM” or “mg/m<sup>3</sup>”. Using the ARROW DOWN button, scroll down to the desired unit of measure and push the MENU button to accept.

**BATTERY:** This menu item provides the user with two different battery options that can be selected. **NOTE:** The YESAIR is supplied from the factory, and configured for rechargeable NiMH batteries. If the user wishes to change from one type to another (eg. Rechargeable to Alkaline), they must first make the change through the “SETTINGS” menu. Reference more information on pages 18-19. Battery types available are: “NIMH “ (rechargeable) or “ALKALINE” (disposable). Using the ARROW DOWN button, scroll down to the battery type desired and press the MENU button to accept.

**KEYPAD:** This menu item allows the user to leave the keypad operational for anyone using the instrument or lock it so the settings cannot be changed by anyone. A lock symbol appears at the bottom of the LCD display to indicate the keypad lock has been engaged. Anyone trying to use the keypad will encounter a display requesting a four digit security code. The selections are “NORMAL” or “LOCKED”. The instrument is supplied with a generic security code for all lockable functions. It is “1,2,3,4”. Using the ARROW DOWN button, scroll down to the desired selection and press the MENU button to accept.

**DISPLAY:** The menu item provides the user with four settings that can be adjusted for the LCD, alpha-numeric, digital display. “BACKLIGHT”, “NORMAL”, “BLANK”, “CONTRAST”.

**BACKLIGHT:** This menu item allows the user to set the LCD display backlight to **ON** or **OFF**. Switching it off saves on battery power. Use the ARROW DOWN button or ARROW UP button to scroll to the desired setting (ON or OFF) and press the MENU button to make the change. Once the backlight has been switched “ON” through the menu, it will remain on for about 30-seconds. After that, the user can then push any button momentarily to activate the backlight for short periods of time. The backlight will remain on for 30-seconds with each activation from an arrow button then automatically turn off to save battery power.

**NORMAL:** This menu item sets the display to the normal view of all installed sensors and their real time gas values. *Example:* If a user has blanked the LCD display or locked the keypad to prevent tampering, the “normal” function resets everything.

**BLANK:** This menu item allows the user to ‘blank’ the LCD display so nobody can view the real time readings. This does not affect the data logging function at all. Using the ARROW DOWN button, scroll to the desired setting and push the MENU button to accept. The LCD goes completely blank. To view the LCD display again, push the MENU button and you will be required to enter the security code.

## 5.0 MENU FUNCTION DETAILS

### SETTINGS, DISPLAY

**CONTRAST:** This menu item allows the user to adjust the contrast of the LCD display. There are seven settings available and they are listed as: **“ONE, TWO, THREE, FOUR, FIVE, SIX, SEVEN”**. Using the ARROW DOWN button, scroll down to the desired value and push the MENU button to accept.

**PUMP:** This menu item allows the user to select **“REG FLOW”** (regular flow) or **“HIGH FLOW”** for the pump. Regular flow sets the pump flow rate to approximately 0.5 LPM default. High flow increases the flow rate and should be used when a hose and probe is attached. The higher flow rate helps to overcome the resistance of the hose and probe to maintain at least 0.5 LPM flow into the instrument. Using the ARROW DOWN button, scroll to the desired setting and push the MENU button to accept.

**PASSCODE:** This menu item allows the user to set a security pass code to prevent other people from changing the instrument settings. Pressing the MENU button at this option takes the user to the pass code set up screen. The user is required to enter the existing pass code first. Use the ARROW UP or ARROW DOWN buttons to input the existing pass code then push the MENU button. The display then indicates it is ready for a new pass code to be entered. Use the ARROW UP or ARROW DOWN buttons to set the desired numbers for a pass code. Pressing the MENU button at this point saves the new pass code. With the display indicating **“NEW PASS CODE HAS BEEN SAVED”**.

**DEFAULT:** This menu item allows the user to quickly set up the instrument operating parameters. Pressing the MENU button at this menu function saves the default settings and the following message appears on the LCD: **“DEFAULT SET UP HAS BEEN APPLIED”**.

**DATALOG:** This menu item allows the user to set up the information gathering (data logging) function that instructs the microprocessor what and how to write information to the flash memory card. The selections are: **“DEFAULT”**, **“SET UP”**, **“ACTIVATE”**, **“STOP LOG”**, **“LOCATION”**, **“MEM CARD”**.

**DEFAULT:** This menu item provides the end user with a quick set up option for the data logging function. It sets up basic parameters for the information gathering function. The end user can still enter other menus to manually set up or change all parameters of the information gathering if desired for customizing it to their application. The LCD indicates **“DEFAULT SETUP HAS BEEN SAVED”**

**DEFAULT SETUP:** 1 min sample rate, Start logging on startup, End logging when file full, Location = NONE

**SET UP:** This menu item allows the user to select the sampling rate. Eight sampling rates are available to choose between, from once every 2-seconds to once every 30-minutes.

Sampling rates available: 2-secs, 10-secs, 30-secs, 1-min, 2-min, 5-min, 15-min, 30-min. After the sampling rate has been selected, the logger START method must be selected: **“STARTUP”** or **“SET TIME”**.

## 5.0 MENU FUNCTION DETAILS

### DATALOG

STARTUP: Logging will start when the YESAIR is turned on and ACTIVATE has been selected from the DATALOG menu

SET TIME: User can set the time and date to start logging

After the START method has been selected the END method must be selected: "FILE FULL", "FIXED", or "SET TIME"

FILE FULL: Logging will stop when the flash card memory is full

FIXED: User selects how many samples to take before logging is stopped.

SET TIME: User can set the time and date to stop logging.

After the END method has been selected, the logging location must be selected. The selections available in the "LOC" (location) menu are:

NONE  
SETUP  
<EMPTY>  
<EMPTY>  
<EMPTY>  
<EMPTY>  
<EMPTY>  
<EMPTY>

Choosing NONE will not set a location for logging. The user can customize this list as described on page 25.

**ACTIVATE:** This menu item allows the user to enable the data log (information recording) session. Press the MENU button at this item and the LCD indicates "DATA LOG HAS BEEN ENABLED"

**NOTE-1:** Once the data logger has been set up, it will not start until "ACTIVATE" has been selected from the DATALOG menu.

**NOTE-2:** If the user experiences an error message "**MEMORY CARD CORRUPT**", the flash card must be formatted with a pc using Windows FAT32 file system.

**NOTE-3:** If memory card is not installed before "activate" is selected, the user will experience an error message "**PLEASE INSTALL MEMORY CARD**". The display will then flip back to the data log menu, awaiting further instructions.

**STOP LOG:** This menu item allows the user to turn off the data log session. Press the MENU button at this item and the LCD indicates "**DATA LOG HAS BEEN STOPPED**".

**LOCATION:** This menu item allows the user to enter names or identifiers (alpha/numeric) for up to six locations for logging purposes. Names are limited to eight characters. Example:

NONE  
SETUP  
KOREA (EXAMPLE)

## 5.0 MENU FUNCTION DETAILS

### DATALOG

**LOCATION:** This menu item allows the user to enter names or identifiers (alpha/numeric) for up to six locations for logging purposes. Names are limited to eight characters.

Example:  
NONE  
SETUP  
KOREA (EXAMPLE)

**MEM CARD:** This menu function provides the user with information about the flash card and a function to format a new card. The selections are:

#### INFO FORMAT

**INFO:** This menu function indicates the size of the flash card memory and the number of CSV files stored, if any.

**FORMAT:** This menu function is used to format all new flash cards. Any flash card provided by the factory has already been formatted. This format function is used to format new flash cards, erase flash cards, and reset flash cards if the memory is corrupt. Use pc to format any card when required and select **ONLY** "FAT-32" file system to format.

**ALARM:** This menu item allows the user to set up alarm set points that would activate the audible alarm. The menu choices are:

#### ALARM SET ALARM

**ALARM:** The menu choices at this point are:

OFF  
ALL  
NEXT...  
CO  
CO2

**NOTE:** Only installed sensors show on this menu, eg. CO, CO2, etc. This menu will only display temperature and RH sensors if an alarm point has been set for them. Go to "SET ALARM" to reference setting alarm set points.

**OFF:** This menu item removes all asterisks in front of all sensors listed (installed) indicating they have been de-selected and will not be included in the alarm set list. Press the MENU button at this menu item and the LCD indicates "**ALARM SET UP HAS BEEN SAVED**". The display then goes back to the alarm menu screen.

**ALL:** This menu item puts an asterisk in front of all sensors listed (installed) indicating they have been selected to have an alarm set point. Press the MENU button at this menu item and the LCD indicates "**ALARM SET UP HAS BEEN SAVED**". The display then goes back to the alarm menu screen.

## 5.0 MENU FUNCTION DETAILS

### ALARM

**NEXT:** Select next after you have highlighted only the sensors you want to have alarm set points for. Press the MENU button at this menu item and the LCD indicates "**ALARM SET UP HAS BEEN SAVED**". The LCD then goes back to the alarm menu.

**TEMP:** This menu item puts an asterisk in front of the temperature sensor (installed) indicating it has been selected to have an alarm set point

**HUMIDITY:** This menu item puts an asterisk in front of the humidity sensor (installed) indicating it has been selected to have an alarm set point.

**CO:** This menu item puts an asterisk in front of the CO sensor (installed) indicating it has been selected to have an alarm set point

**CO2:** This menu item puts an asterisk in front of the CO2 sensor (installed) indicating it has been selected to have an alarm set point.

**NOTE:** Other sensors may be indicated here. Only installed sensors will be on this list. Pressing the MENU button at any of the sensors listed, puts an asterisk in front of the gas name, indicating it has been selected to activate the audible alarm if real-time gas values are above preset alarm levels.

**SET ALARM:** This menu item allows the user to enter an alarm set point for any installed sensor. The user must first enter a four digit security code. Use the UP ARROW or DOWN ARROW and MENU buttons to enter the desired numbers of the security code. When finished push the MENU button and the LCD will accept the code if it was entered correctly and display the list of installed sensors

Using the ARROW DOWN button, scroll down to the first sensor that you wish you enter an alarm set point for then push the MENU button. The display will indicate "ENTER ALARM VALUE". Use the ARROW UP and/or ARROW DOWN buttons to enter the desired numbers then press the MENU button to accept the new value. The LCD will indicate "**NEW ALARM VALUE ENTERED**" and go back to the list of installed sensors.

Once again, use the ARROW DOWN button to scroll down to the next sensor that is to have an alarm set point and repeat the procedure. Each time the MENU button is pressed to accept the new alarm set point, the LCD will go back to the list of sensors and the default cursor position is "**PREVIOUS**". When finished, press the MENU button at "**PREVIOUS**" and the alarm menu will be displayed.

**INFO:** This menu item provides the user with information about the instrument. The choices are for the instrument and installed sensors with serial numbers (does not include temperature and RH sensors as they do not have serial numbers). Example of choices are:

**MONITOR**  
**CO**  
**CO2**

**MONITOR:** LCD indicates instrument serial number and date of manufacture

**CO:** LCD indicates sensor serial number, sensor date code, and calibration information: span and zero dates

## 5.0 MENU FUNCTION DETAILS

### ALARM

**CO2:** LCD indicates sensor serial number, sensor date code, and calibration information: span and zero dates

To access this information, scroll down to the desired choice using the arrow down button and press the MENU button. Once the information has been viewed, press the MENU button to return to the previous menu.

**INFO:** This menu item provides the user with information about the instrument. The choices are for the instrument and installed sensors with serial numbers (does not include temperature and RH sensors as they do not have serial numbers). Example of choices are:

**MONITOR**  
**CO**  
**CO2**

**MONITOR:** LCD indicates instrument serial number and date of manufacture

**CO:** LCD indicates sensor serial number, sensor date code, and calibration information: span and zero dates

**CO2:** LCD indicates sensor serial number, sensor date code, and calibration information: span and zero dates

To access this information, scroll down to the desired sensor choice and using the ARROW DOWN button and press the MENU button. Once the information has been viewed, press the MENU button to return to the previous menu.

**USB:** This menu item allows the user to reset the USB chip if any problems are experienced while trying to communicate with YES Viewer software. After selecting RESET from this menu, the user will receive the message "USB HAS BEEN RESET"

**NOTE:** If you remove the USB cable before shutting down the "YES Viewer" program, the YESAIR may continue to display "PC Mode". Press and hold the MENU button to clear this and return to normal measurement mode.

## 6.0 CALIBRATION PROCEDURE

This section details the calibration procedure and is an extension of the description from pages 19 to 21 of this manual.

**NOTE:** Calibration should always be performed by a trained and experienced technician. Temperature and Relative Humidity sensors must be calibrated using a special chamber and therefore field calibration is not permitted. Only gas sensors can be field calibrated.

## 6.0 CALIBRATION PROCEDURE

### Equipment Required & Cautions:

1) Always ensure batteries are fully charged (if rechargeable batteries are installed) or fresh alkaline batteries are installed. This is especially important when calibrating sensors that are more "current hungry" such as infrared, combustible and PID for TVOCs.

2) Allow a twenty (20) minute warm up period before attempting calibration of any gas sensors. This allows all sensors time to fully warm up and stabilize and produces the most accurate results for calibration.

3) Always perform both zero (null) and span functions on all sensors. Zero function involves flowing 100% Nitrogen into the inlet port of the instrument.

4) Cylinders of Nitrogen and appropriate span gases are required for calibration. Ensure the cylinder regulator has a minimum flow rate of 0.5 LPM to a maximum of 1.0 LPM. The pump inside the YESAIR must not be "drawn down" because of a low flow rate from a cylinder regulator. The result will be inaccurate calibration values. Span gas values should preferably be approximately 40% to 60% of the installed sensor measurement ranges. Always remove cylinder regulators from air and gas cylinders before storing.

Calibration can be achieved from the instrument keypad menu or through the pc information gathering (data logging) software. The following procedure deals only with calibration procedure through the instrument keypad menu. The procedure to achieve calibration from the pc software can be found in the separate software manual.

### PROCEDURE:

#### ZERO:

Press the MENU button on the instrument to enter the main menu. Using the ARROW DOWN button scroll down to "**CALIBRATE**" and press the MENU button. The LCD will indicate "**(CODE) ENTER SECURITY CODE**". The calibration function is security code protected to prevent unauthorized personnel or personnel that have not been trained, from performing this important function.

Enter the security code correctly and the LCD indicates "**CAL**" and the next menu selections "PREVIOUS", "SPAN" "ZERO".

**NOTE:** If incorrect code is input the LCD INDICATES "INVALID SECURITY CODE ENTERED" and the user is taken back to the basic menu.

Use the ARROW DOWN button to scroll down to the desired function and press the MENU button to select it. The LCD then indicates "PREVIOUS", "ALL" and lists all installed sensors. Use the ARROW DOWN button to scroll to the desired sensor then push the MENU button to select. The LCD then indicates "ZERO" and "APPLY GAS NOW". A bar along the bottom of the LCD indicates the progress. At 100% it indicates "ZEROING SENSOR" and another bar indicates the progress. Upon completion, the LCD indicates "ZERO HAS BEEN UPDATED" and the LCD returns to the "CAL" menu.

Procedure: Attach the cylinder flow regulator to the cylinder of 100% Nitrogen, open the valve fully and attach the brass fitting to the inlet fitting of the YESAIR.

## 6.0 CALIBRATION PROCEDURE

### ZERO:

Repeat this procedure for all installed sensors.

**NOTE:** If the user neglects to flow 100% Nitrogen over CO<sub>2</sub> and O<sub>2</sub> sensors or zero air over all other sensors, the instrument indicates an error.

Selecting the span procedure is the same as selecting the zero procedure. Simply use the ARROW DOWN button to scroll to "SPAN" then push the MENU button to select. From the "CAL" menu, use the ARROW DOWN button to scroll to the desired sensor then push the MENU button to select. The LCD indicates "SPAN" and the sensor selected and the gas value last used to span the selected sensor. Using the ARROW UP and/or ARROW DOWN button to set the value, one digit at a time. Next press the MENU button and the LCD indicates "SPAN" and "APPLY GAS NOW..." and the bar along the bottom of the LCD indicates the progress.

**Note:** Pressing the MENU button during the first stage of this procedure results in a cancelation of the span procedure.

### SPAN:

#### YESAIR, 3 (THREE) POINT SPAN CALIBRATION PROCEDURE

YESAIR now provides 3 point span calibration for infrared CO<sub>2</sub> and infrared CH<sub>4</sub> percent volume range sensors **ONLY**, to provide the maximum accuracy. First complete the zero calibration. Next, the following steps guide you through the 3-point calibration procedure. For **ALL** other sensors, follow the single point calibration procedure indicate right after the 3-point calibration procedure.

Press the MENU button on the instrument to enter the main menu. Using the ARROW DOWN button scroll down to "**CALIBRATE**" and press the MENU button. The LCD will indicate "**(CODE) ENTER SECURITY CODE**". The calibration function is security code protected to prevent unauthorized personnel or personnel that have not been trained, from performing this important function. Default Security code = 1234

Enter the security code correctly and the LCD indicates "**CAL**". Using the DOWN ARROW scroll to "**SPAN**" and push the MENU button. The next menu indicates installed gas sensors.

The LCD indicates the list of installed sensors. Use the ARROW DOWN button to scroll to the CO<sub>2</sub> sensor and press the MENU button again.

The LCD moves to the "**SPAN**" menu and indicates "**ENTER 1<sup>ST</sup> GAS VALUE**". The cursor flashes over the first of four digits indicating the user must set the correct 1<sup>st</sup> span gas value approximately 1000 ppm. This value must match the gas concentration on the cylinder of span gas for that specific sensor, and then press the MENU button.

The LCD indicates "**APPLY GAS NOW...**". A scroll bar at the bottom of the LCD indicates the progress on a scale of 0 to 100% as the instrument waits for sensor to stabilize to the span gas. Then the LCD indicates "**SPANNING CO<sub>2</sub>**". Once again the scroll bar at the bottom of the LCD indicates the span progress on a scale of 0 to 100%.

## 6.0 CALIBRATION PROCEDURE

### SPAN:

Upon completion, the LCD indicates “**ENTER 2<sup>nd</sup> GAS VALUE**” and cursor flashes over the first of four digits indicating the user must set the correct 2<sup>nd</sup> span gas value approximately 2000 ppm. This value must match the gas concentration on the cylinder of span gas for that specific sensor, and then press the MENU button.

The LCD indicates “**APPLY GAS NOW...**”. A scroll bar at the bottom of the LCD indicates the progress on a scale of 0 to 100% as the instrument waits for sensor to stabilize to the span gas. Then the LCD indicates “**SPANNING CO2**”. Once again the scroll bar at the bottom of the LCD indicates the span progress on a scale of 0 to 100%. Upon completion, the LCD indicates “**ENTER 3<sup>rd</sup> GAS VALUE**” and cursor flashes over the first of four digits indicating the user must set the correct 3<sup>rd</sup> span gas value approximately 4000 ppm. This value must match the gas concentration on the cylinder of span gas for that specific sensor, and then press the MENU button.

The LCD indicates “**APPLY GAS NOW...**”. A scroll bar at the bottom of the LCD indicates the progress on a scale of 0 to 100% as the instrument waits for sensor to stabilize to the span gas. Then the LCD indicates “**SPANNING CO2**”. Once again the scroll bar at the bottom of the LCD indicates the span progress on a scale of 0 to 100%. Upon completion, the LCD indicates “**SPAN HAS BEEN UPDATED**”

**NOTE:** If for any reason user doesn't want all three points' calibration then it can be overridden by pressing & hold ARROW UP button till new screen will appears.

### YESAIR, 1 (ONE) POINT SPAN CALIBRATION PROCEDURE

First complete the zero calibration procedure as indicated on page-28.

Next, press the MENU button on the instrument to enter the main menu. Using the ARROW DOWN button scroll down to “**CALIBRATE**” and press the MENU button. The LCD will indicate “**(CODE) ENTER SECURITY CODE**”. The calibration function is security code protected to prevent unauthorized personnel or personnel that have not been trained, from performing this important function.

Enter the security code correctly and the LCD indicates “**CAL**”. Using the DOWN ARROW scroll to “**SPAN**” and push the MENU button. The next menu indicates installed gas sensors.

The LCD indicates the list of installed sensors. Use the ARROW DOWN button to scroll to the first sensor to be span adjusted and press the MENU button again.

The LCD moves to the “**SPAN**” menu and indicates “**SPAN GAS VALUE**”. The cursor flashes over the first of four digits indicating the user must set the correct span gas value. This value must match the gas concentration on the cylinder of span gas for that specific sensor. Use the ARROW UP, ARROW DOWN and MENU button to set the span gas value then press the MENU button. If the span gas concentration is 50 (example) the value should read “050.0”.

## 6.0 CALIBRATION PROCEDURE

### YESAIR, 1 (ONE) POINT SPAN CALIBRATION PROCEDURE

The LCD moves to the SPAN menu and indicates "**APPLY GAS NOW...**". A scroll bar at the bottom of the LCD indicates the progress on a scale of 0 to 100% as the instrument waits for sensor to stabilize to the span gas. Then the LCD indicates "**SPANNING CO**". Once again the scroll bar at the bottom of the LCD indicates the span progress on a scale of 0 to 100%. Upon completion, the LCD indicates "**SPAN HAS BEEN UPDATED**" and goes back to the "**CAL**" menu.

Repeat this procedure for all installed sensors.

**NOTE-1:** If the user neglects to flow 100% Nitrogen over CO2 and O2 sensors or zero air over all other sensors, the instrument indicates an error.

**NOTE-2:** The O2 sensor does not indicate the first span menu screen (**APPLY GAS NOW**). For this reason, ensure any Oxygen span gas utilized is connected and flowing to the sensor before entering the span menu. Alternatively, use the ambient environment as a source of 20.9% volume O2 but make sure you do not exhale in the direction of the pump inlet fitting. The CO2 you exhale will influence the value of the Oxygen reading. It is the only sensor that skips the first span calibration menu screen.

## 7.0 ADDING OR CHANGING PLUG-AND-PLAY SENSORS

The YESAIR accommodates up to seven sensors. Two of those sensors are temperature and relative humidity and these sensors are permanently installed in all instruments as a standard. Five of the sensor locations accommodate only gas sensors. Three of the sensor locations visible along the back edge of the sensor cover accommodate only electrochemical toxic gas and/or Oxygen sensors. There are two sensor locations located along the front edge of the sensor cover. Each of the two front edge sensor locations can accommodate either the infrared CO2 sensor, the PID sensor or the catalytic combustible (flammable) gas sensor. See photo reference on page-31.

All YESAIR gas sensors are plug-and-play smart sensors. They can be added or changed at any time. The procedure to add or change a sensor is as follows:

- 1) Shut the instrument off. If the power adapter is plugged in, **UNPLUG IT BEFORE PROCEEDING.** "**WARNING**" LEAVING AC ADAPTER PLUGGED IN WHILE CHANGING SENSORS CAN SERIOUSLY DAMAGE SENSORS. THIS DAMAGE WILL NOT BE COVERED UNDER WARRANTY.
- 2) Loosen the single securing screw in the centre of the sensor cover on the top of the instrument. Carefully remove the cover.
- 3) If you are removing a sensor, identify the one to be removed by the label on the side of the sensor then carefully grasp the sensor by the sides and pull upwards with a slight rocking motion to unplug it from the sensor sockets in the transmitter circuit board. **DO NOT DROP** the sensor (permanent damage could occur). The removed sensor should be stored in a clean, dry container, preferably with anti-static foam.

## 7.0 ADDING OR CHANGING PLUG-AND-PLAY SENSORS

### SENSORS

4) If another sensor is to be installed in it's place, ensure it is of the same "type" (electrochemical, infrared, PID/Catalytic), to be accommodated by the sensor location recently vacated. Carefully grasp the new sensor by the sides and line up all of the pins on the smart sensor board attached to the bottom of the sensor with the sockets on the transmitter board. Once the pins are all aligned, gently push the sensor down into the sockets in the transmitter circuit board. If it does not seem to be easy to insert the new sensor, **DO NOT FORCE** it. Double check the pin to socket alignment and try again.

**NOTE:** If no sensor is to be utilized in a specific sensor location, the opening must be filled with a sensor blanking plug to allow sampled air to reach all sensor locations.

5) Reattach the sensor cover and tighten the securing screw (**DO NOT OVER TIGHTEN**).

6) Switch the instrument on and allow at least 20 to 30 minutes of warm up time before using.

7) Once the sensor has been warmed / stabilized, perform a zero function using the pushbuttons on the front of the instrument. This function is part of the calibration procedure indicated on page-27. This can be performed in room air if you know the air in the environment is clean. If the sensor is CO<sub>2</sub> or O<sub>2</sub>, 100% Nitrogen (N<sub>2</sub>) must be flowed over the sensor as part of the zero function.

**NOTE-1:** If the newly installed sensor is not zero adjusted after installation, as outlined above, the display may indicate a slight reading of the target gas even in a clean environment.

**NOTE-2: For best accuracy,** all sensors should be zero adjusted and bump tested after being installed.

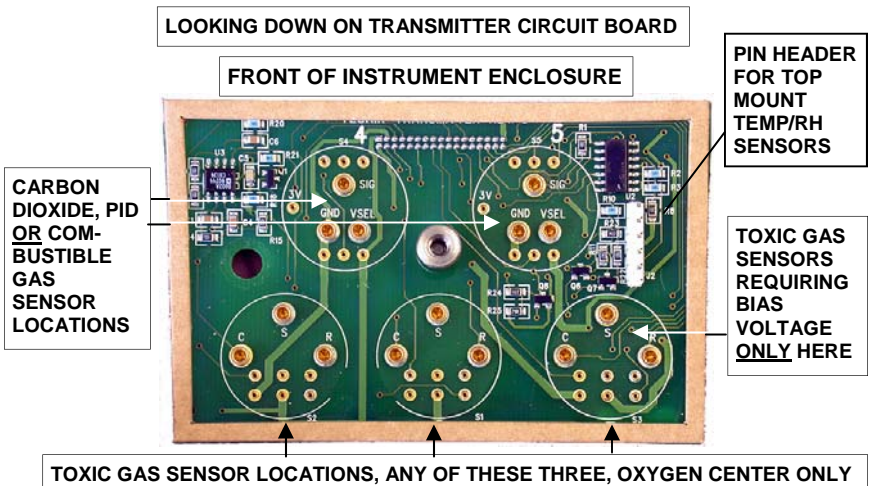

## 7.0 ADDING OR CHANGING PLUG-AND-PLAY SENSORS

## 8.0 INFORMATION RECORDING (DATA LOGGING) OPERATION

### INSTALLATION OF “YES Viewer” SOFTWARE

- 1) Insert supplied CD in CD/DVD Rom drive
- 2) Accept the terms and conditions
- 3) Follow the instructions
- 4) Finally complete the installation by clicking on Finish tab

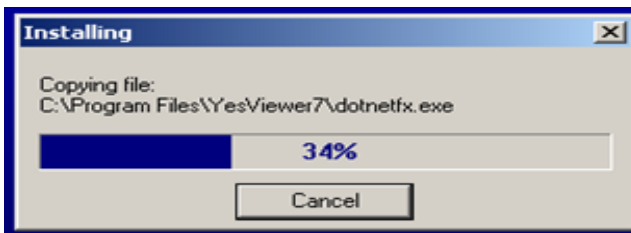

After Installation the YES Viewer Icon will appear automatically on your computer desktop. Double click on YES Viewer Icon on your Desktop.

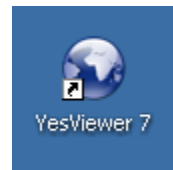

**FOR MORE INFORMATION AND COMPLETE INSTRUCTIONS IN THE USE OF THE YES VIEWER INFORMATION LOGGING SOFTWARE PROGRAM, CONSULT THE “INFORMATION DATA LOGGING SOFTWARE MANUAL”.**

## 9.0 MAINTENANCE

Externally, the YESAIR requires only cleaning with a damp cloth, wiping off the exterior surface and basic inspection for obvious damage or problems. Internally, sensors should be maintained because they have a specific life span. As they age, they must be calibrated (null and span adjusted) for accuracy. If one or more sensors do not respond to span gas, check the age of the sensor as they may have expired. Refer to the sensor replacement and calibration sections of this manual for more details. Contact the factory for service to replace expired sensors or any other parts that are required.

## 10.0 YESAIR TROUBLE SHOOTING

**Problem-1.00: YESAIR does not communicate with YES Viewer software.**

**NOTE:** YESAIR must be switched on and have completed warm up cycle to be able to communicate with the YES Viewer software. It must be in the normal display mode indicating all installed sensors on the LCD.

**Problem: YESAIR displays “PC MODE” when it is not communicating with the YES Viewer software”.**

Solution:

1.01 Hold down the MENU button for 5-seconds to bring the YESAIR back to the main sensor display window.

1.02 If the YESAIR still indicates “PC MODE”, unplug the 6V adapter from the YESAIR and remove the batteries.

1.03 Plug the 6V adapter into the YESAIR and hold the MENU button in for 3-seconds to start the instrument. Insert the batteries when unit has started.

### **Disclaimer Notifications**

**For firmware version 3.0, use software version 7.0**

## 11.0 ACCESSORIES

1) Hard shell, foam-lined, carrying / transport case. P/N 6010.20



2) Extended operation (short term) external battery. P/N YES-AIR BATT AA

Provides almost double the operating time for YESAIR. Effective, indeed recommended when using YESAIR with two infrared sensors installed or one infrared and one combustible sensor installed. Attaches to rear of YESAIR with Velcro and plugs into a port at rear of instrument.

**NOTE:** YESAIR must be ordered with this accessory. It cannot be installed in the field. Instruments in use can be shipped back to be factory retrofitted.

EXTENDED OPERATION  
BATTERY PACK, PLUGS  
INTO REAR OF YESAIR

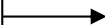

## 11.0 ACCESSORIES

### 3) Extended operation (long term) external battery. P/N YES-AIR BATT EXT

Provides enough battery power for approximately 7 to 10 days of continuous (24 hours per day) operating time for YESAIR when used in areas where line voltage is not available for wall adapter. This battery option is installed in a hard shell carrying case with its own battery charger and battery monitoring circuit to maximize battery life.

**NOTE:** Because of the size of this lead acid battery, the **recharge time** is approximately **26-hours**.

Photo not available for this accessory at the  
printing date of this manual

### 5) Hand-held probe. P/N YES-HHPROBE-10 (10"), P/N YES-HHP[ROBE-30 (30").

Supplied with 30" of hose and allows the user to attach a sample probe (wand) to reach into hard to get at areas for sampling.

**NOTE:** Remote sampling is for gases only. Temperature and RH sensors are mounted on top of YESAIR.

