

# TSI Thermal Anemometry Probes

...for Maximum Flexibility in Designing Your Thermal Anemometry Application

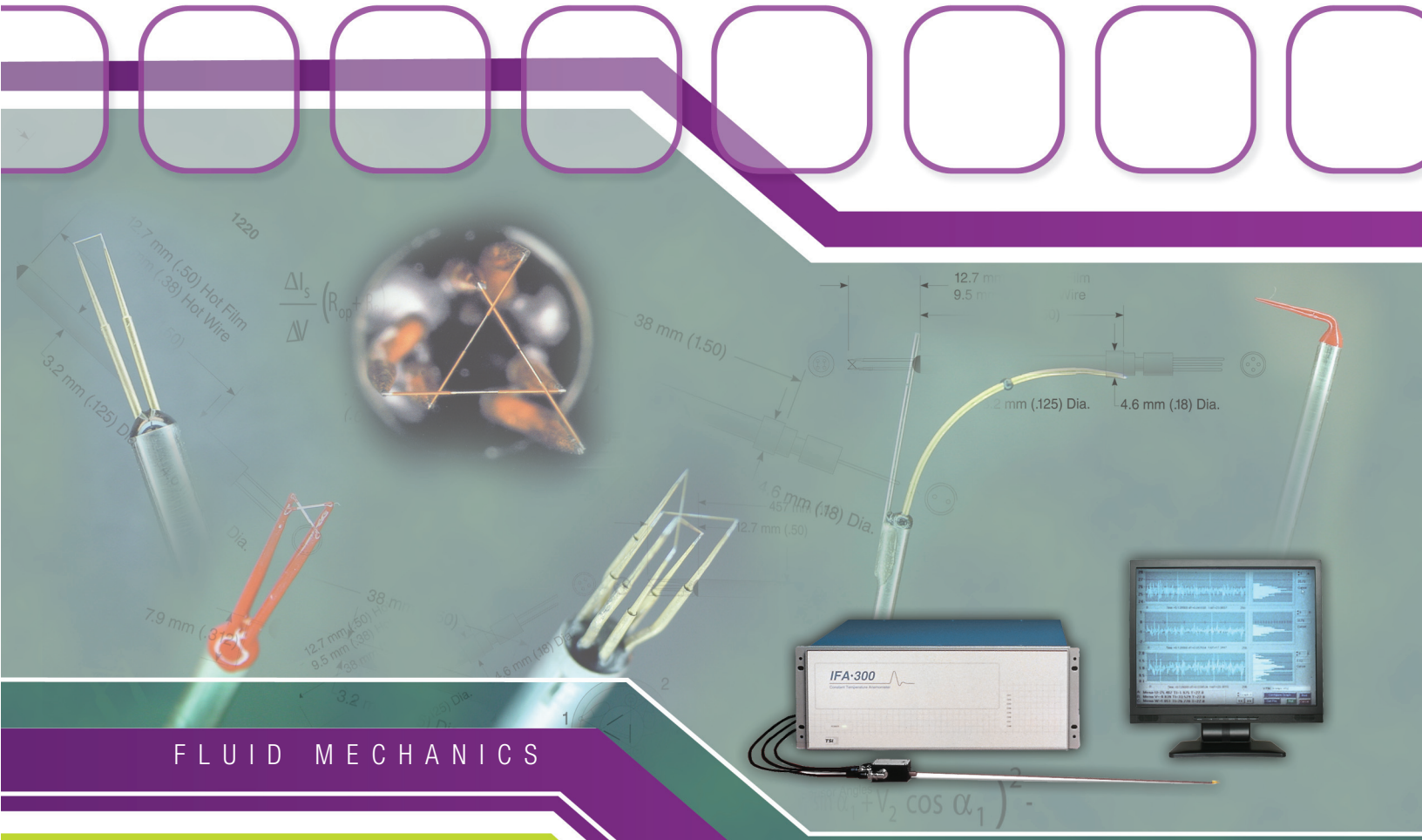

FLUID MECHANICS

Thermal Anemometry



TRUST. SCIENCE. INNOVATION.

## Table of Contents

<b>Probe Selection Guide</b>	2
<b>Probe Specifications</b>	4
<b>Sensor Specifications</b>	5
<b>Thermal Anemometry Probes</b>	6
For Single Cylindrical Sensors	6
For Dual Cylindrical Sensors	10
For Three Cylindrical Sensors	13
<b>Probe Supports</b>	14
Single-Sensor Probe Supports	14
Dual-Sensor Probe Supports	16
<b>Probe Accessories</b>	18
<b>Determining Operating Resistance of a Sensor</b>	22
<b>Probe Calibration</b>	22
<b>Model Number Index</b>	26

# Introduction to Thermal Anemometry

Thermal anemometers measure fluid velocity by sensing the changes in heat transfer from a small, electrically-heated element exposed to the fluid. In the “constant temperature anemometer,” the cooling effect caused by the flow passing the element is balanced by the electrical current to the element, so the element is held at a constant temperature. The change in current due to a change in flow velocity shows up as a voltage at the anemometer output.

A key feature of the thermal anemometer is its ability to measure very rapid changes in velocity. This is accomplished by coupling a very fine sensing element (typically a wire four to six microns in diameter or a platinum thin film deposited on a quartz substrate) with a fast feedback circuit which compensates for the drop in the natural sensor response. Time response to flow fluctuations as short as a few microseconds can be achieved. For this reason, the thermal anemometer has become a standard tool for researchers studying turbulence. The small sensor size, normally only a millimeter in length, also makes the technique valuable in applications where access is difficult or larger sensors obstruct the flow.

Since the actual measurement is of heat transfer between the sensor and its environment, the thermal anemometer will respond to changes in parameters other than velocity, such as temperature, pressure, and fluid composition. While this adds to versatility, it also means that when more than one parameter is changing, special techniques must be used to extract velocity. Modern systems will automatically correct the velocity reading for temperature changes.

When selecting a thermal anemometry probe, the user must choose between film and wire sensors. The choice is based on the fluid characteristics, the velocity range, the number of velocity components, contamination in the flow, and access to the flow.

The traditional sensor for research thermal anemometry has been a fine wire. For very low turbulence intensities, the wire sensor is still superior—and the smaller the wire, the better the results. For those applications that require a wire sensor, the 4 micrometer-diameter platinum-coated tungsten wire is almost a standard for measurements at normal room temperatures and below. Tungsten is very strong and has a high temperature coefficient of resistance. It will, however, deteriorate at high temperatures in oxidizing atmospheres (such as air). Platinum wires, though weaker, can also be made very small and will withstand high temperature in an oxidizing atmosphere. If more strength is needed at high temperatures, an alloy such as platinum-iridium should be selected.

The rigidity and strength of cylindrical film sensors, relative to wire sensors, make them the preferred choice in a wide range of thermal anemometry applications. Rigidity is especially important for multi-sensor measurements where the algorithms used for data reduction assume a straight sensor. Also, film sensors are less susceptible to damage or coating by particles in the flow than are wire sensors.

## Probe Selection

TSI offers a wide range of thermal anemometry probes, each specially adapted for a particular application. The broadest probe classifications are based on the fluid measured (liquid or gas) and the number of velocity components.

The probe family includes hot film sensors and hot wire sensors. The choice between them is critical for most applications. Hot films consist of a thin film of platinum deposited on a quartz substrate, typically a cylinder attached to the sensor supports. Various cylinder diameters permit different spatial resolutions.

This catalog describes a full line of standard probes mainly classified by sensor type, the number of sensors, and the direction the mean flow moves relative to the probe body. They should handle the vast majority of applications. The catalog also includes probe supports (usually required since they contain the necessary cable connections) and probe shields which help protect the delicate sensor.

## Four Steps in Choosing a Probe

The four steps outlined here help determine the key measurement and environmental parameters that must be known in order to select the best probe and probe support for an application. The selection process then becomes relatively straightforward.

### Step 1. Identify environmental conditions (determines the applicable sensors)

**High temperature gases**—Sensors are normally operated well above the environment temperature. The maximum operating temperature of film sensors is 425°C, while for tungsten wires it is 300°C. Platinum wires can operate at much higher temperatures but are much weaker than tungsten. Platinum iridium is stronger than platinum but has a lower temperature coefficient (providing lower S/N ratio). The probe must also be selected for the appropriate temperature range.

**Clean liquids**—Most liquids are sufficiently conductive that the sensor element must be insulated. Thus, only coated film sensors (“W” designation) can be used. Standard construction techniques for probes used in conductive liquids limits the fluid temperature to approximately 30°C. In a truly insulating liquid (e.g. oil), a non-coated sensor should be used since it tends to collect less contamination. In liquids, boundary layer lag can substantially reduce the expected frequency response.

### Step 2. Number of velocity components to be measured (there are limits to the magnitude of the turbulence intensity that can be accurately measured)

**A single cylindrical sensor** perpendicular to the flow will give a good measurement of the instantaneous velocity in the mean flow direction.

**Two cylindrical sensors**, properly oriented, will measure two components of velocity.

**Three cylindrical sensors**, properly oriented, will measure all three velocity components.

### Step 3. Hot wires versus cylindrical film sensors where either can be used

**Hot wires**—Provide the best S/N ratio and generally better frequency response than film sensors. With multiple sensors, they do not stay positioned as well (lengthen and bend when heated), causing errors in velocity component calculations.

**Cylindrical film sensors**—Generally do not contaminate as easily (due to larger diameter) and will not shift resistance due to strain in a high velocity environment or due to particle impact.

### Step 4. Probe and support selection

Once the type and number of sensors is determined, further selections depend on the access to the flow and where the measurement is made. Right angle adapters, miniature probes, and cross flow designs are all variations that help you get the sensor where it belongs with minimum flow field disturbance.

## X-Probe Selection

When selecting an X-probe, keep in mind that an X-probe measures two components of velocity (U and V) that are both in the plane formed by the two sensors. The U and V components will each be at 45 degrees to each sensor. It is assumed that the flow is two-dimensional, with the W component (normal to the plane formed by the two sensors) small in comparison to the total velocity vector. The X-probe should be aligned such that the major flow is in the U direction.

## Special Designs

If you find that no standard probe meets your requirements, define your measurement needs according to the steps outlined and contact TSI. This is often an iterative process as we work with you to get the best possible answer, but it is one that has proved worthwhile to thousands of users around the world, each having a unique application.

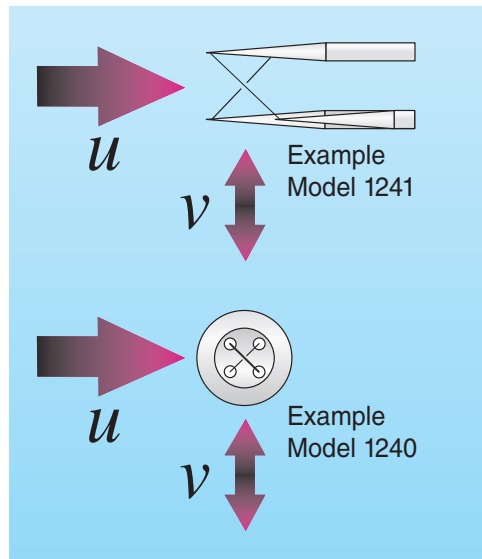

## How To Use This Catalog

Once you have completed the above steps, you are ready to use the catalog to find the correct probe and probe support for your application. As closely as possible, the catalog has been designed to lead you logically to the probe you need.

The catalog is organized according to the following characteristics:

- First, by broad sensor type
- Second, by the number of sensors (one, two, or three) mounted on the probe
- Third, by the direction of the mean flow relative to the probe body (end flow or cross flow)
- Fourth, by the specific configuration of the probe (high temperature, miniature, etc.)

Once you have located the type of probe you need, review the list of recommended sensors to determine if the specific sensor type (air or water, wire or film) which you need is available. See the sensor specification table on page 5 for a description of the sensor designations listed in the probe section and detailed specifications on each type of sensor.





When the probe type has been determined, the final step is to locate the best probe support and shield. A wide variety of supports and shields are listed in the pages following the probes. Your choice will be largely based on access requirements.

# Sensor Probe Selection

The chart below lists all the probes featured in this catalog and summarizes their key selection characteristics:

Model No.*	Page Number	Designation	Size	Temperature	Fluid	Sensor Type	Sensor Orientation	Sensor Position
<b>Cylindrical Sensors</b>								
1201	6	S	R	L	G	F	90	I
1210	6	S	R	L	G,L	W,F	90	I
1220	6	S	R	H	G	W,F	90	I
1260A	6	S	M	L	G,L	W,F	90	I
1276	7	S	SM	L	G,L	W,F	90	I
1214	7	S	R	L	G	W,F	90	I
1213	7	S	R	L	G,L	W,F	45	I
1211	7	S	R	L	G	W,F	0	I
1212	8	S	R	L	G,L	W,F	90	U
1222	8	S	R	H	G	W,F	90	U
1262A	8	S	M	L	G,L	W,F	90	U
1277	8	S	SM	L	G	F	0	U
1218	9	BL,S	R	L	G,L	W,F	90	U
1261A	9	BL,S	M	L	G,L	W,F	90	U
1241	10	X	R	L	G,L	W,F	45	I
1248A	10	X	M	L	G,L	W,F	45	I
1240	10	X	R	L	G,L	W,F	90	I
1247A	11	X	M	L	G,L	W,F	90	I
1246	11	X	R	L	G,L	W,F	45	U
1245	11	X	R	L	G,L	W,F	90	U
1249A	12	X	M	L	G,L	W,F	45	U
1243	12	BL,X	R	L	G,L	W,F	45	U
1244	12	II	R	L	G,L	W,F	90	I
1299	13	T	OP	L	G	F	54	I
1299A	13	T	OP	L	G	F	-	U

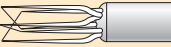
\*Probes are listed in numerical order in the index on page 26.

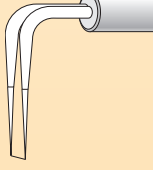
<b>Sensor Designation</b> Cylindrical Sensors	<b>S</b> =Single <b>II</b> =2 parallel sensors <b>X</b> ="X" probe	<b>T</b> =Triple sensor <b>BL</b> =Boundary layer
<b>Sensor Size</b> (Diameter of probe body closest to sensor)	<b>R</b> =Regular (3.2 mm) <b>M</b> =Miniature (1.5 mm) <b>SM</b> =Subminiature (0.9 mm) <b>OP</b> =One Piece (4.6 mm)	
<b>Temperature</b> (Maximum exposure temperature of probe body)**	<b>L</b> =150°C, (except 60°C for 1201) <b>H</b> =300°C Maximum temperature for water probes is approximately 30°C	
<b>Fluid</b>	<b>G</b> =Gas <b>L</b> =Liquid	
<b>Sensor Type</b>	<b>W</b> =Wire <b>F</b> =Platinum film	
<b>Sensor Orientation</b> (Relative to connector end of probe)	<b>0</b> =0° <b>90</b> =90° <b>45</b> =45° <b>54</b> =54.74°	   
<b>Sensor Position</b> (Relative to connector end of probe)	<b>I</b> =In-line <b>U</b> =Upstream	 

# Specifications

## Hot Wire and Hot Film Sensors

Type	Dash No. Designation Suffix in Probe No.	Diameter (D) of Sensing Area or Width in mm (in.)	Length (L) of Sensing Area in mm (in.)	Distance Between Supports in mm (in.)	Maximum Sustained Ambient Temperature (C)	Maximum Sensor Operating Temperature (C)	Temperature Coefficient of Resistance (/C)
<b>Hot Wire</b>							
Tungsten Platinum Coated	-T1.5	3.8 (0.00015)	1.27 (0.05)	1.52 (0.06)	150	300	0.0042
Platinum	-P2	5.1 (0.0002)	1.27 (0.05)	1.27 (0.05)	300	800	0.00385
Platinum Iridium (Alloy)	-PI2.5	6.3 (0.00025)	1.27 (0.05)	1.27 (0.05)	300	800	0.0009
Platinum Iridium (Alloy)	-PI5	12.7 (0.0005)	1.27 (0.05)	1.27 (0.05)	300	800	0.00094
<b>Hot Film Gas</b>							
Platinum	-10A	25.4 (0.001)	0.25 (0.01)	0.76 (0.03)	150/300	425	0.0024
Platinum	-10	25.4 (0.001)	0.51 (0.02)	1.27 (0.05)	150/300	425	0.0024
Platinum	-20	50.8 (0.002)	1.02 (0.04)	1.65 (0.065)	150/300	425	0.0024
<b>Hot Film Liquid</b>							
Platinum	-10AW	25.4 (0.001)	0.25 (0.01)	.76 (0.03)	30	67	0.0024
Platinum	-10W	25.4 (0.001)	0.51 (0.02)	1.27 (0.05)	30	67	0.0024
Platinum	-20W	50.8 (0.002)	1.02 (0.04)	1.65 (0.065)	30	67	0.0024

# Probes for Single Cylindrical Sensors

Probes for single cylindrical sensors are used for one-dimensional flow measurements. Within this category, the Model 1210 and its equivalent disposable probe, the Model 1201, are the most frequently used probe models.

## Model 1201 Disposable Probe

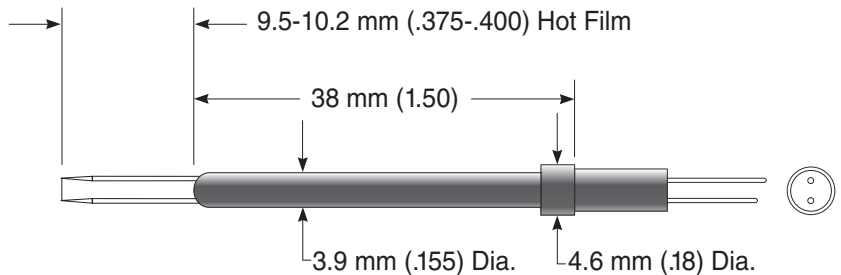

**Recommended Sensors**  
**For Gas Applications**  
 1201-6 (package of 6)  
 1201-12 (package of 12)  
 The 1201 probes have a -20 film sensor.  
 Max. Fluid Temp. = 60°C

## Model 1210 General Purpose Probe

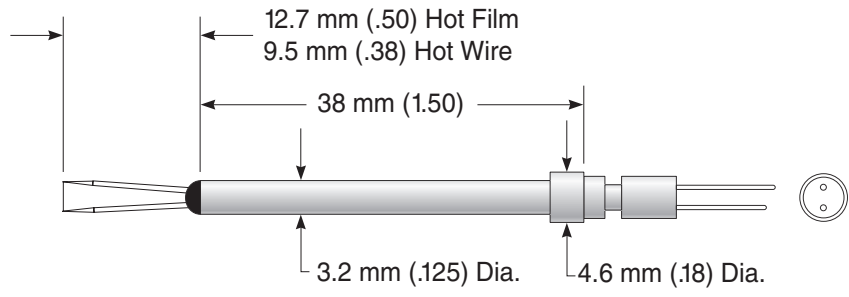

**Recommended Sensors**  
**For Gas Applications**  
 1210-T1.5  
 1210-20  
 Max. Fluid Temp. = 150°C  
**For Liquid Applications**  
 1210-20W

## Model 1220 High Temperature Straight Probe

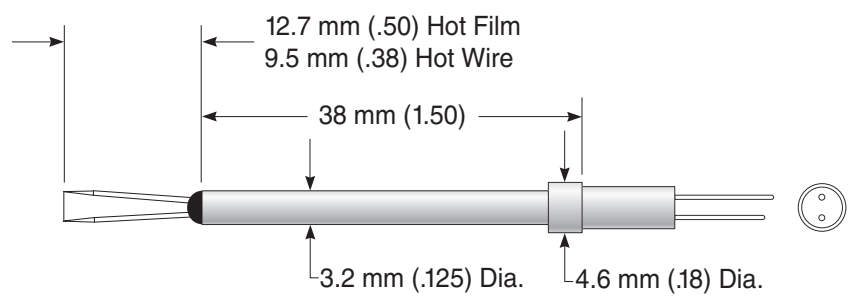

**Recommended Sensors**  
**For Gas Applications**  
 1220-PI2.5  
 1220-20  
 Max. Fluid Temp. = 300°C

## Model 1260A Miniature Straight Probe

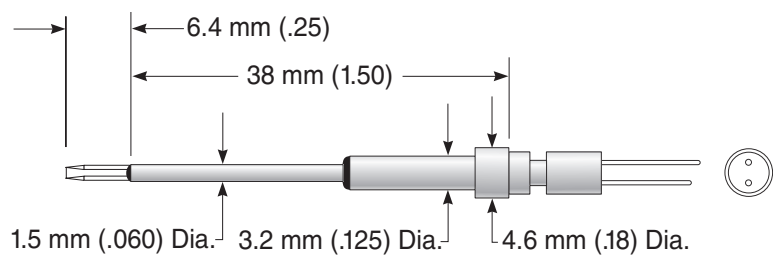

**Recommended Sensors**  
**For Gas Applications**  
 1260A-T1.5  
 1260A-10  
 Max. Fluid Temp. = 150°C  
**For Liquid Applications**  
 1260A-10W

# Probes for Single Cylindrical Sensors

## Model 1276 Subminiature Straight Probe

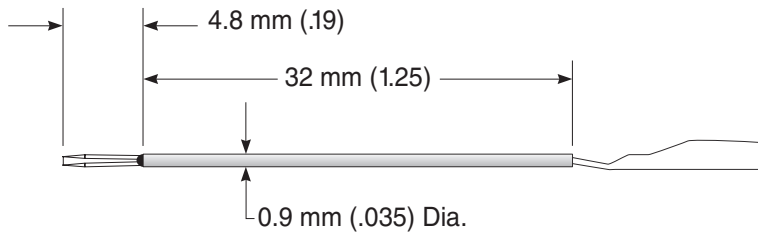

\* Use for temperature measurement only with constant current bridge.

### Recommended Sensors

#### For Gas Applications

1276-P.5\*  
1276-10A  
Max. Fluid Temp. = 150°C

#### For Liquid Applications

1276-10AW

## Model 1214 Streamlined Probe

For high speed (e.g. supersonic) flows

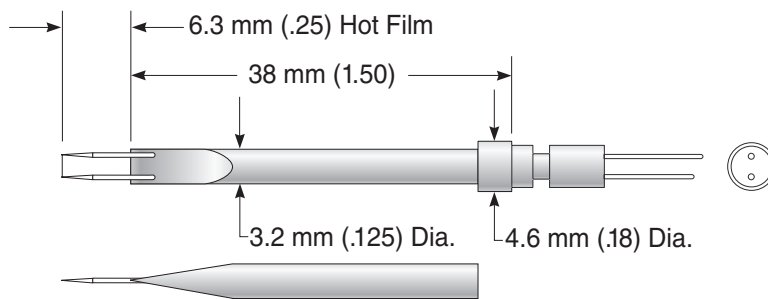

### Recommended Sensors

#### For Gas Applications

1214-T1.5  
1214-20  
Max. Fluid Temp. = 150°C

## Model 1213 Sensor 45° to Probe

Single sensors 45° to probe axis can be used in steady flows to measure turbulent shear stress or two components of velocity by rotating the probe about its axis.

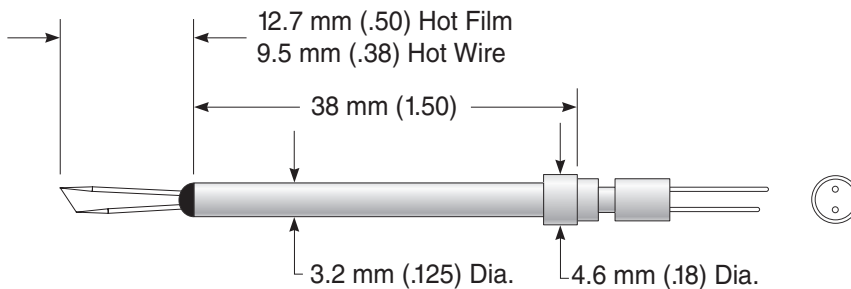

### Recommended Sensors

#### For Gas Applications

1213-T1.5  
1213-20  
Max. Fluid Temp. = 150°C

## Model 1211 Standard Probe

In cross flow applications, probe interference is reduced by mounting the sensor parallel to the probe body.

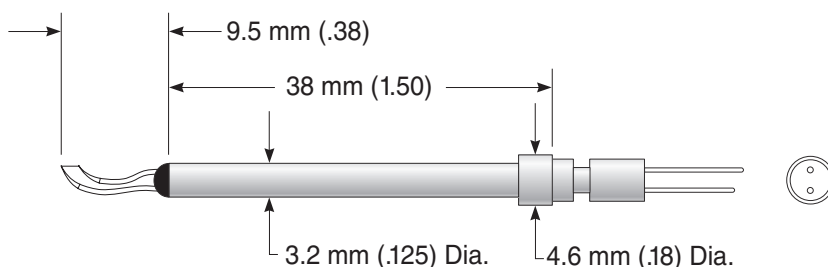

### Recommended Sensors

#### For Gas Applications

1211-T1.5  
1211-10  
1211-20  
Max. Fluid Temp. = 150°C

# Probes for Single Cylindrical Sensors

For minimum probe interference in cross flow applications, the sensor needles are bent so the sensor is upstream of the probe.

## Model 1212 Standard Single Sensor Probe

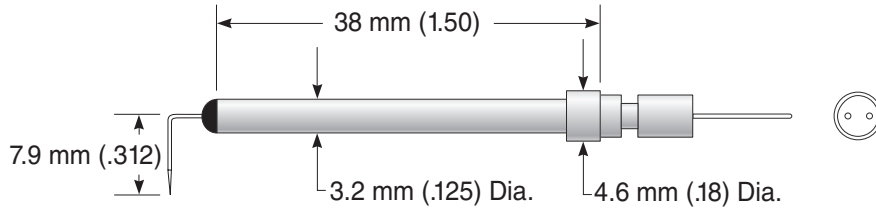

**Recommended Sensors**

**For Gas Applications**

- 1212-T1.5
- 1212-20
- Max. Fluid Temp.= 150°C

**For Liquid Applications**

- 1212-20W

## Model 1222 High Temperature Single Sensor Probe

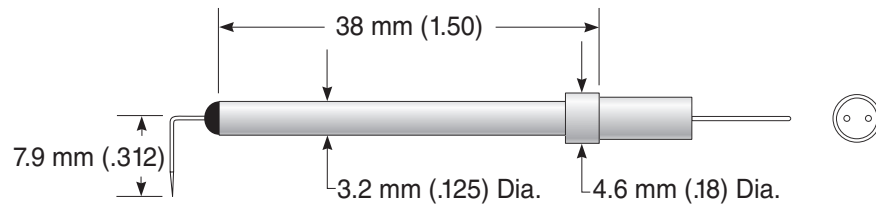

**Recommended Sensors**

**For Gas Applications**

- 1222-PI2.5
- 1222-20
- Max. Fluid Temp.= 300°C

## Model 1262A Miniature Probe

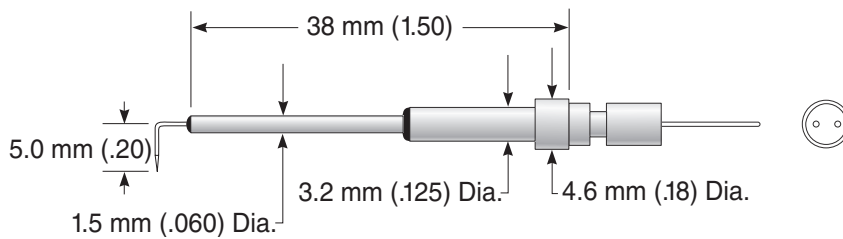

**Recommended Sensors**

**For Gas Applications**

- 1262A-T1.5
- 1262A-10
- Max. Fluid Temp.= 150°C

**For Liquid Applications**

- 1262A-10W

## Model 1277 Subminiature Probe

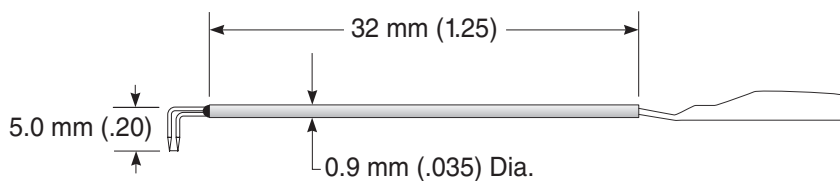

**Recommended Sensors**

**For Gas Applications**

- 1277-10A
- Max. Fluid Temp.= 150°C

# Probes for Single Cylindrical Sensors

Boundary layer probes provide a protective pin to allow measurements very near the surface and a long radius bend to minimize disturbances.

## Model 1218 Standard Boundary Layer Probe

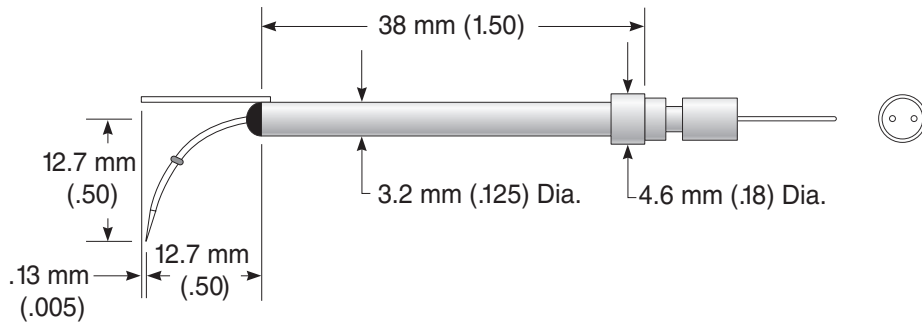

### Recommended Sensors

#### For Gas Applications

- 1218-T1.5
- 1218-10
- 1218-20
- Max. Fluid Temp.= 150°C

#### For Liquid Applications

- 1218-20W

## Model 1261A Miniature Boundary Layer Probe

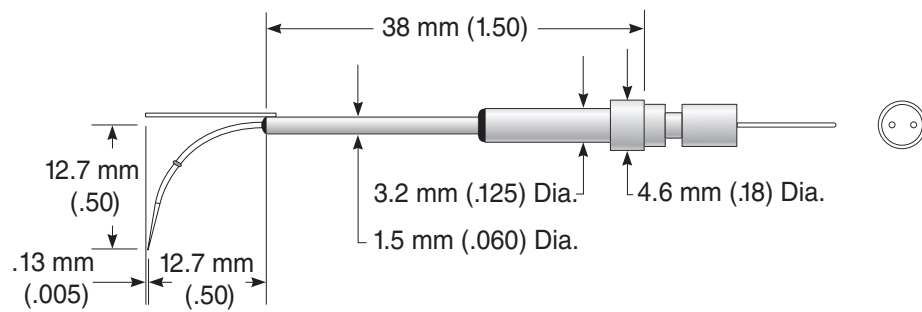

### Recommended Sensors

#### For Gas Applications

- 1261A-T1.5
- 1261A-10
- Max. Fluid Temp.= 150°C

#### For Liquid Applications

- 1261A-10W

## Probes for Dual Cylindrical Sensors

Dual sensor probes position two sensors in close proximity, generally in an “X” configuration, for measuring two components of flow and the correlation between them. For accurate measurements, the maximum turbulence intensity is limited by the sensitivity to the flow perpendicular to the measured components.

### Model 1241 End Flow “X” Probe

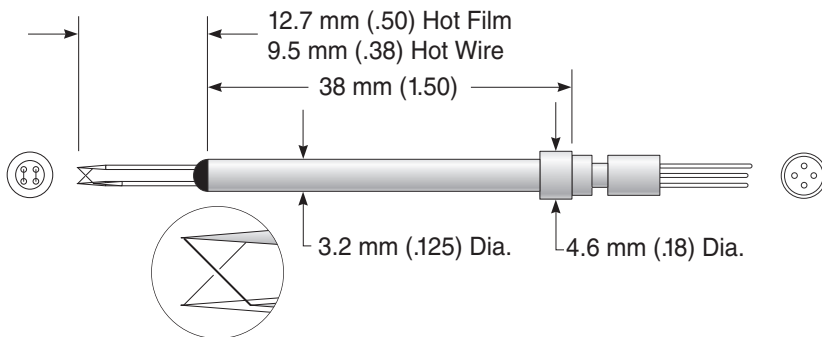

#### Recommended Sensors

##### *For Gas Applications*

1241-T1.5

1241-20

Max. Fluid Temp.= 150°C

##### *For Liquid Applications*

1241-20W

### Model 1248A Miniature End Flow “X” Probe

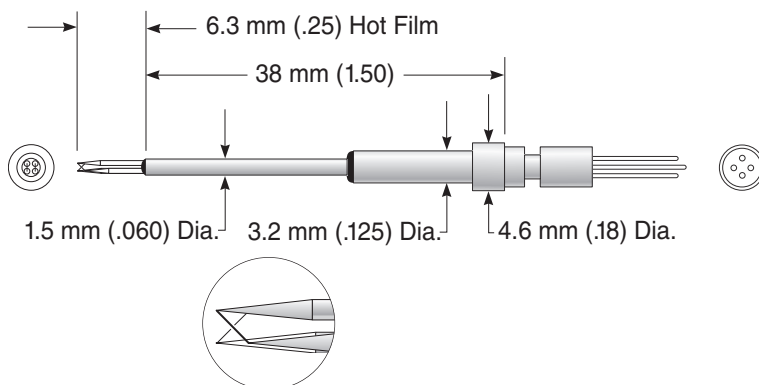

#### Recommended Sensors

##### *For Gas Applications*

1248A-T1.5

1248A-10

Max. Fluid Temp.= 150°C

##### *For Liquid Applications*

1248A-10W

### Model 1240 Standard Cross Flow “X” Probe

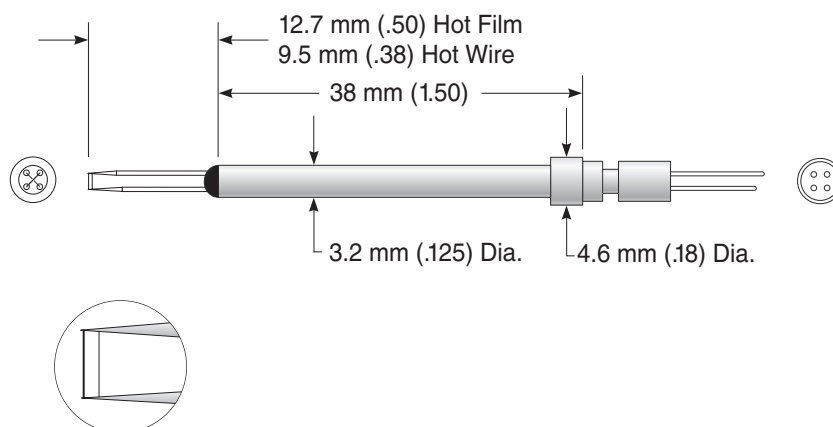

#### Recommended Sensors

##### *For Gas Applications*

1240-T1.5

1240-20

Max. Fluid Temp.= 150°C

##### *For Liquid Applications*

1240-20W

# Probes for Dual Cylindrical Sensors

## Model 1247A Miniature Cross Flow "X" Probe

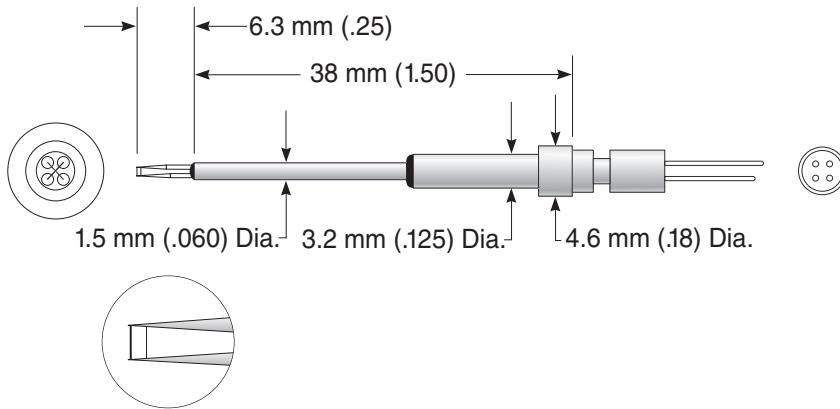

### Recommended Sensors

#### For Gas Applications

- 1247A-T1.5
- 1247A-10
- Max. Fluid Temp.= 150°C

#### For Liquid Applications

- 1247A-10W

## Model 1246 Cross Flow "X" Probe, Sensors Upstream

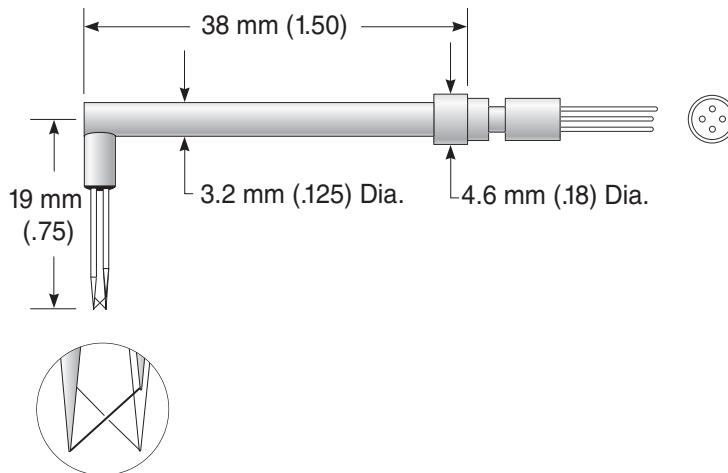

### Recommended Sensors

#### For Gas Applications

- 1246-T1.5
- 1246-20
- Max. Fluid Temp.= 150°C

#### For Liquid Applications

- 1246-20W

## Model 1245 Cross Flow "X" Probe, Sensors Upstream

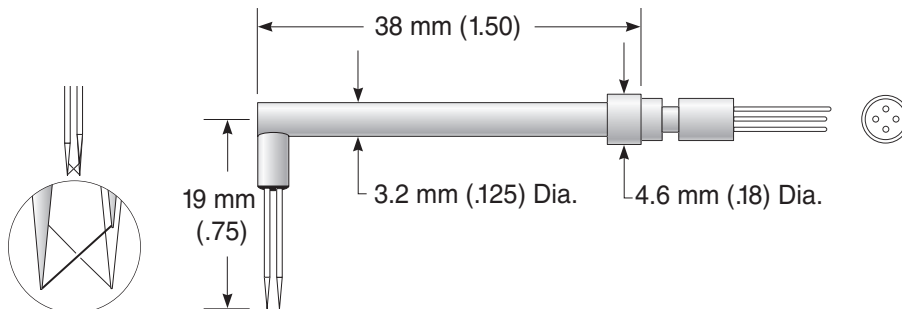

### Recommended Sensors

#### For Gas Applications

- 1245-T1.5
- 1245-20
- Max. Fluid Temp.= 150°C

#### For Liquid Applications

- 1245-20W

# Probes for Dual Cylindrical Sensors

## Model 1249A Miniature Cross Flow "X" Probe, Sensors Upstream

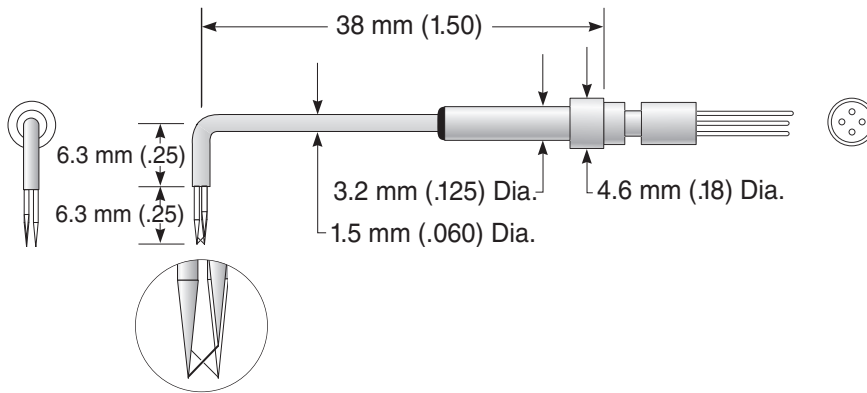

### Recommended Sensors

#### For Gas Applications

1249A-T1.5  
1249A-10  
Max. Fluid Temp.= 150°C

#### For Liquid Applications

1249A-10W

## Model 1243 Boundary Layer Cross Flow "X" Probe, Sensors Upstream

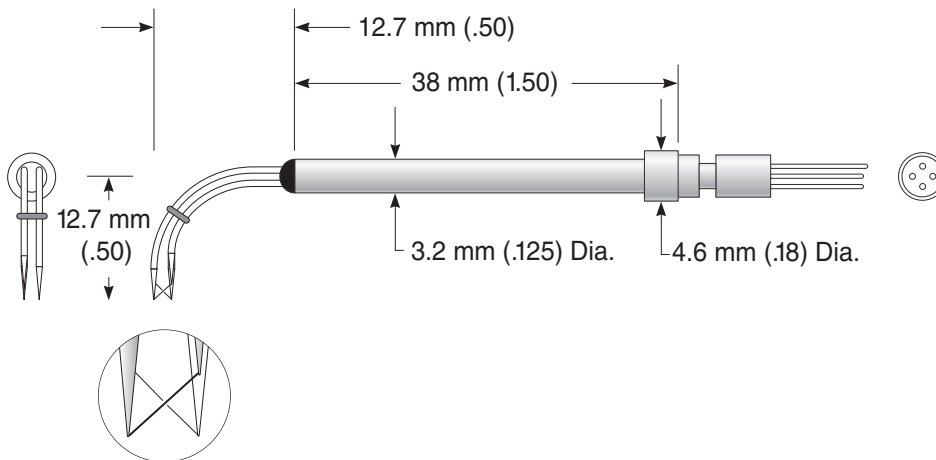

### Recommended Sensors

#### For Gas Applications

1243-T1.5  
1243-20  
Max. Fluid Temp.= 150°C

#### For Liquid Applications

1243-20W

## Model 1244 End Flow Parallel Sensor Probe

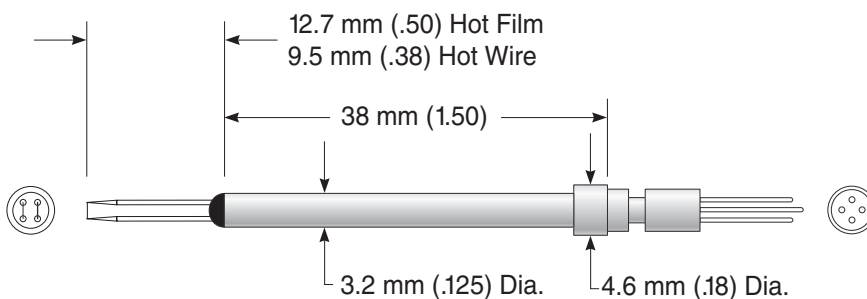

### Recommended Sensors

#### For Gas Applications

1244-T1.5  
1244-20  
Max. Fluid Temp.= 150°C

#### For Liquid Applications

1244-20W

# Probes for Three Cylindrical Sensors

Three-sensor probes are used to locate three sensors in close proximity. They are generally used to measure all three velocity components. Good measurements require that the flow vector stays within the one octant defined by the three sensors. The sensors are located optimally for maximum spatial resolution and minimum probe interference.

## Model 1299 End Flow 3-D Probe

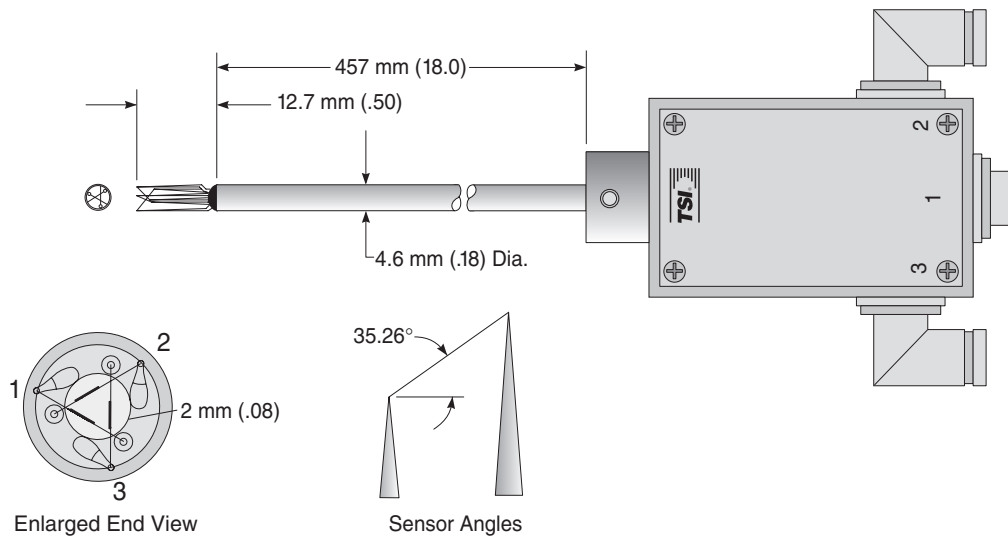

### Recommended Sensors

#### For Gas Applications

1299-18-20

Max. Fluid Temp.= 150°C

## Model 1299A Cross Flow 3-D Probe

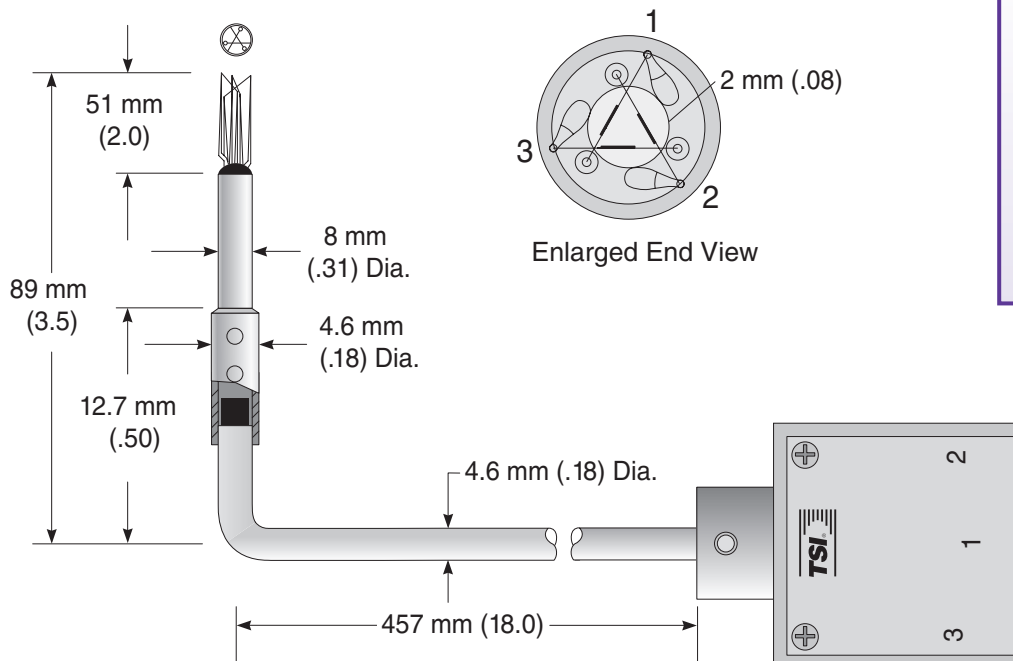

### Recommended Sensors

#### For Gas Applications

1299A-18-20

Max. Fluid Temp.= 150°C

# Single Sensor Probe Supports

## Model 1150 Standard Probe Support

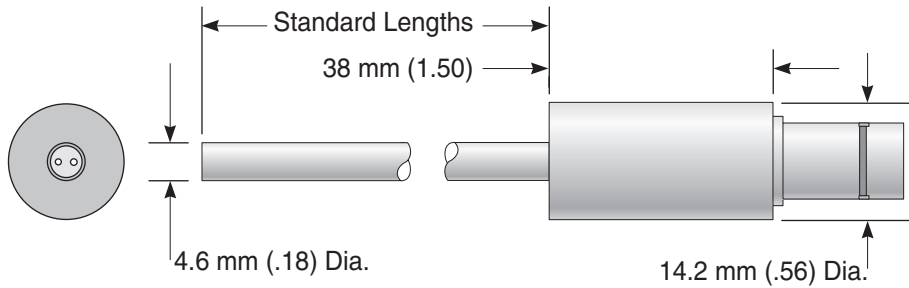

Designed for most standard TSI single sensor plug-in probes.

### Specify

1150-6 for 152 mm (6 in.) length  
1150-18 for 457 mm (18 in.) length  
1150-36 for 915 mm (36 in.) length  
Max. Fluid Temp.= 150°C

## Model 1160 High Temperature Probe Support

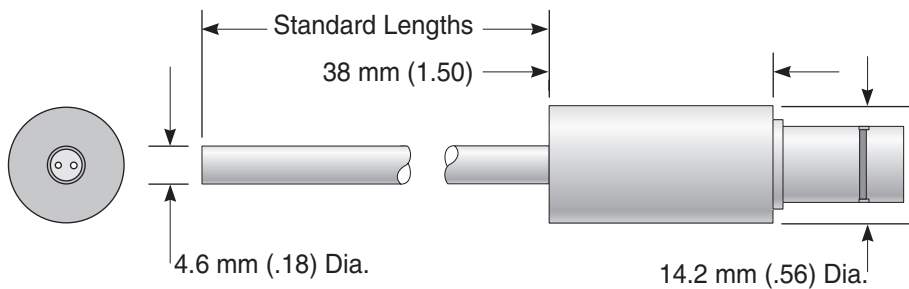

Designed for most standard TSI single sensor plug-in probes.

### Specify

1160-6 for 152 mm (6 in.) length  
1160-18 for 457 mm (18 in.) length  
Max. Fluid Temp.= 300°C

## Model 1151 Probe Support

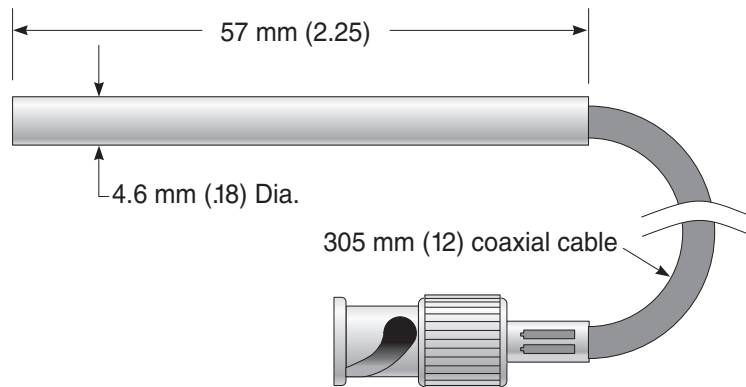

Convenient probe support for small spaces.

### Specify

1151-1  
Max. Fluid Temp.= 150°C

# Single Sensor Probe Supports

## Model 1159 Immersible Probe Support

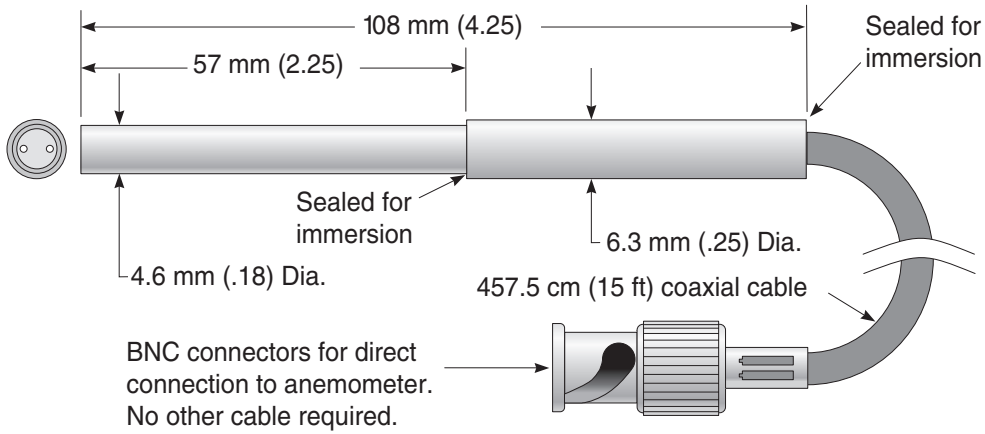

Small probe can be immersed entirely for liquid flow applications.

**Specify**  
1159-15

## Model 1152 90° Angle Adapter

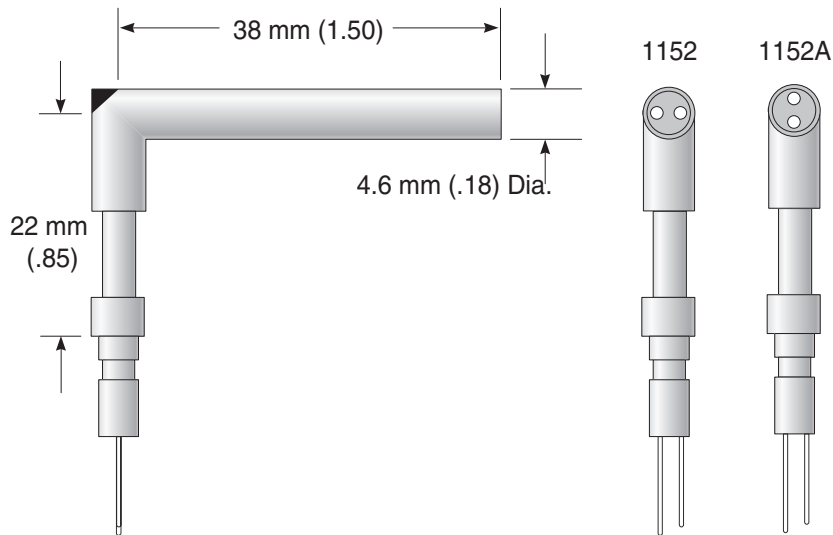

Right angle bend provides access to upstream points with straight probes.

**Specify**  
1152  
1152A

# Dual Sensor Probe Supports

## Model 1155 Standard Probe Support

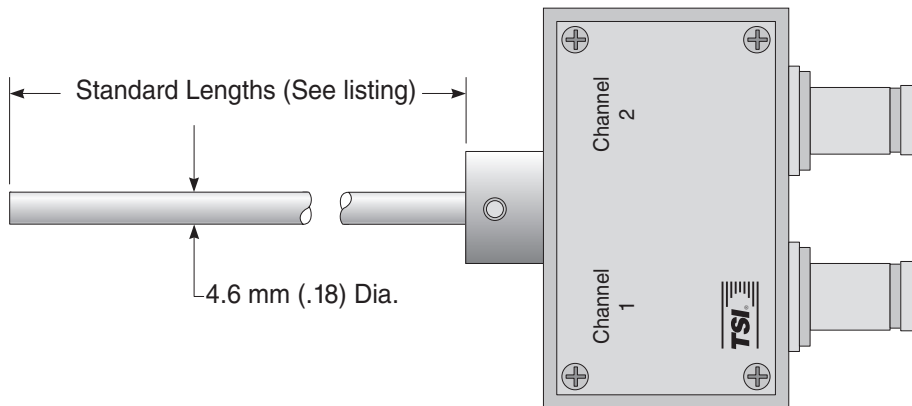

Designed for most standard TSI dual sensor plug-in probes.

### Specify

1155-6 for 152 mm (6 in.) length  
1155-18 for 457 mm (18 in.) length  
1155-36 for 915 mm (36 in.) length  
Max. Fluid Temp.= 150°C

## Model 1156-1 Probe Support

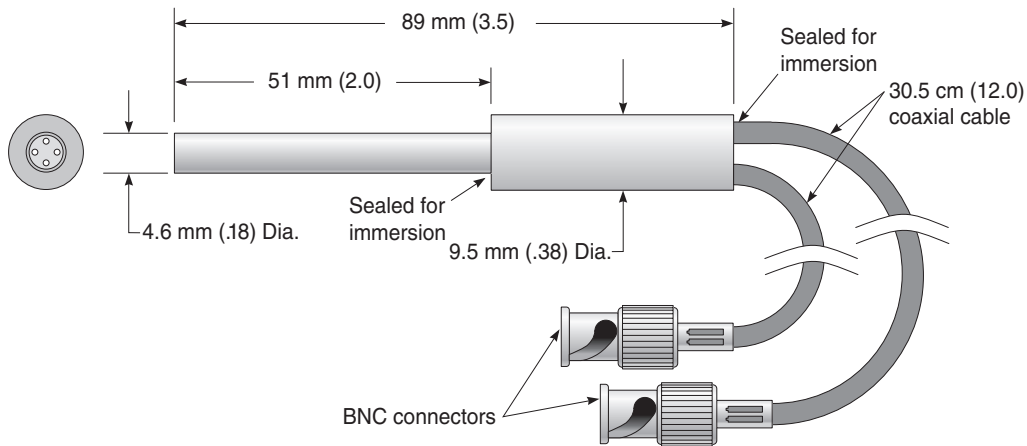

Convenient probe support for small spaces.

### Specify

1156-1  
Max. Fluid Temp.= 150°C

# Dual Sensor Probe Supports

## Model 1157 90° Angle Adapter

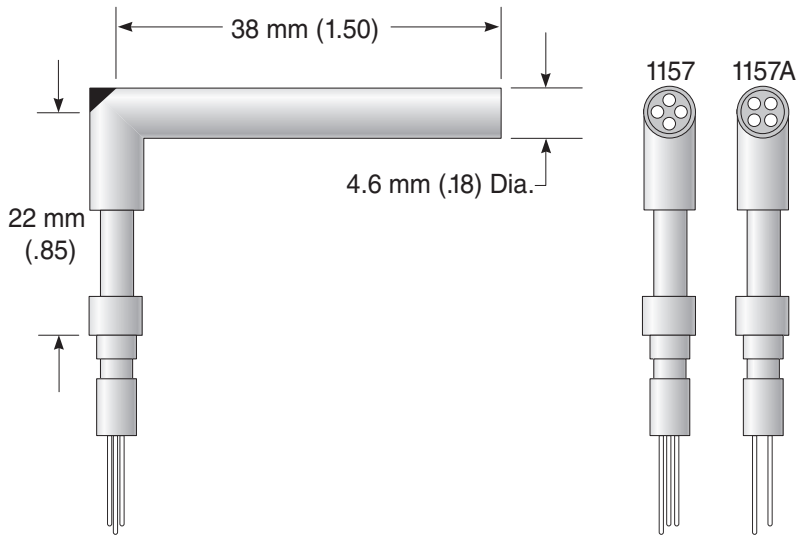

Right angle bend provides access to upstream points with straight probes.

**Specify**  
 1157  
 1157A (for use with Models 1240 and 1247A probes only)

## Model 1154 Dual Sensor Probe Support for Liquids

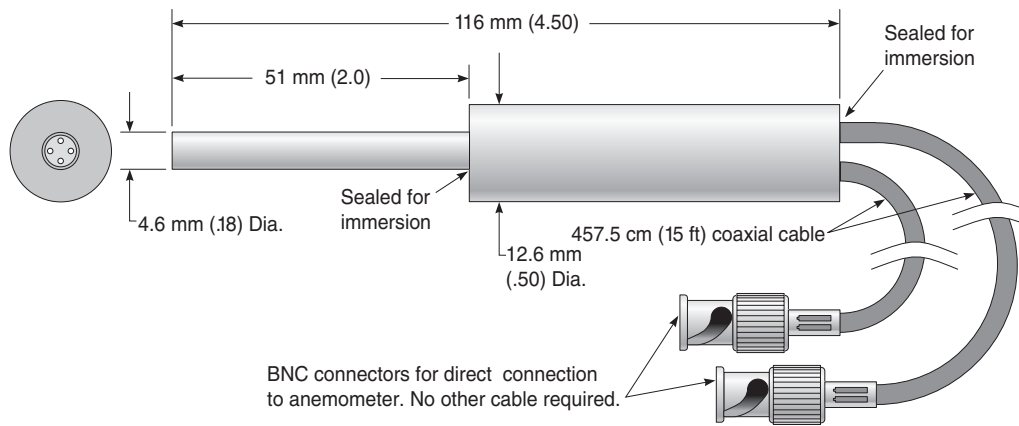

Small probe can be immersed for liquid flow applications.

**Specify**  
 1154-15

# Probe Accessories

## Model 1139 Shield With Window

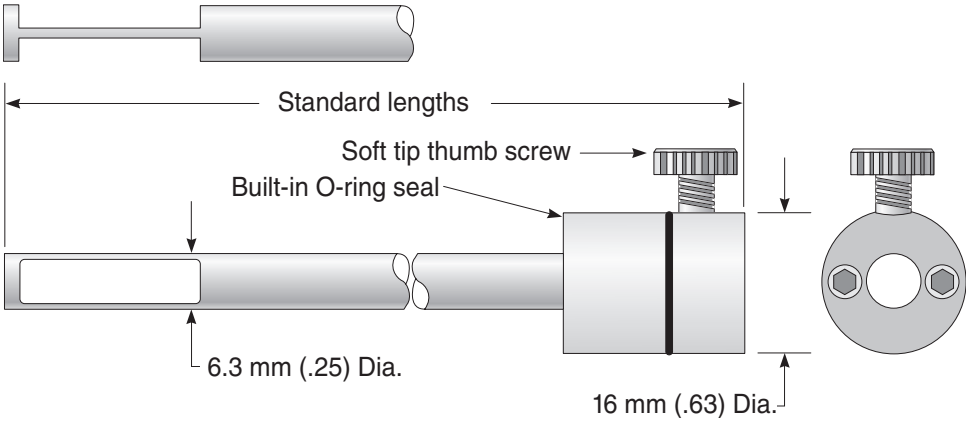

Completely protects sensor while providing opening for cross-flow measurements. Probe can be extended beyond end for unobstructed measurements. Fits Model 1150 Probe Supports.

**Specify**

- 1139-6 for 152 mm (6 in.) length
- 1139-18 for 457 mm (18 in.) length
- 1139-36 for 915 mm (36 in.) length

## Model 1158 Locking Protective Shield

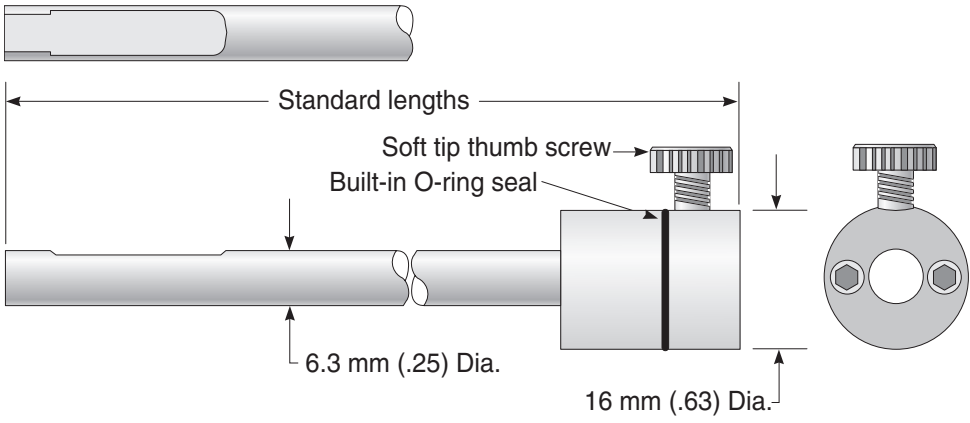

Protects probe when used as a shield, locks probe into socket when extended. Provides sturdy support for probe. Fits Model 1150 Probe Supports and most standard probes.

**Specify**

- 1158-6 for 152 mm (6 in.) length
- 1158-18 for 457 mm (18 in.) length
- 1158-36 for 915 mm (36 in.) length

## Model 1132 Wire Shield Model 1133 Miniature Wire Shield

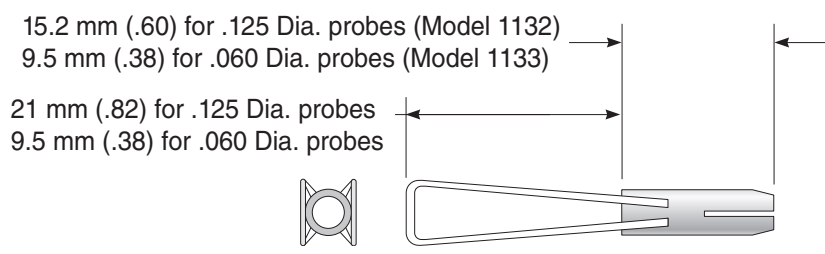

Protects probe from breakage while in use. Can be installed and removed as required using friction fit.

**Specify**

- 1132 for 3.18 mm (1/8 in.) diameter probes
- 1133 for 1.5 mm (.060 in.) diameter probes

# Probe Accessories

## Model 1108 BNC Subminiature Probe Adapter

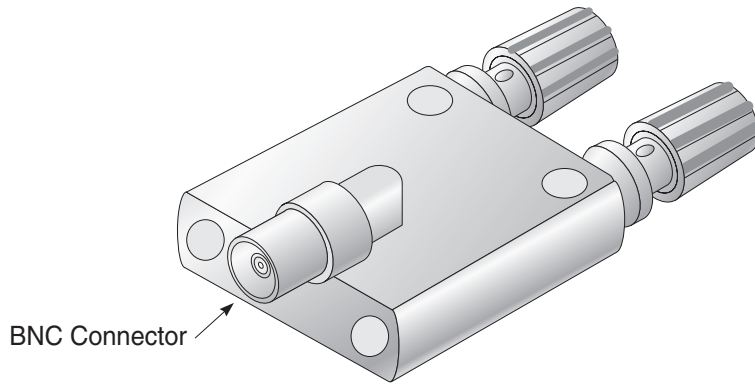

Adapts from probe wires to BNC connector for subminiature probes with wire leads.

**Specify**  
1108

## Model 1138 Mounting Blocks

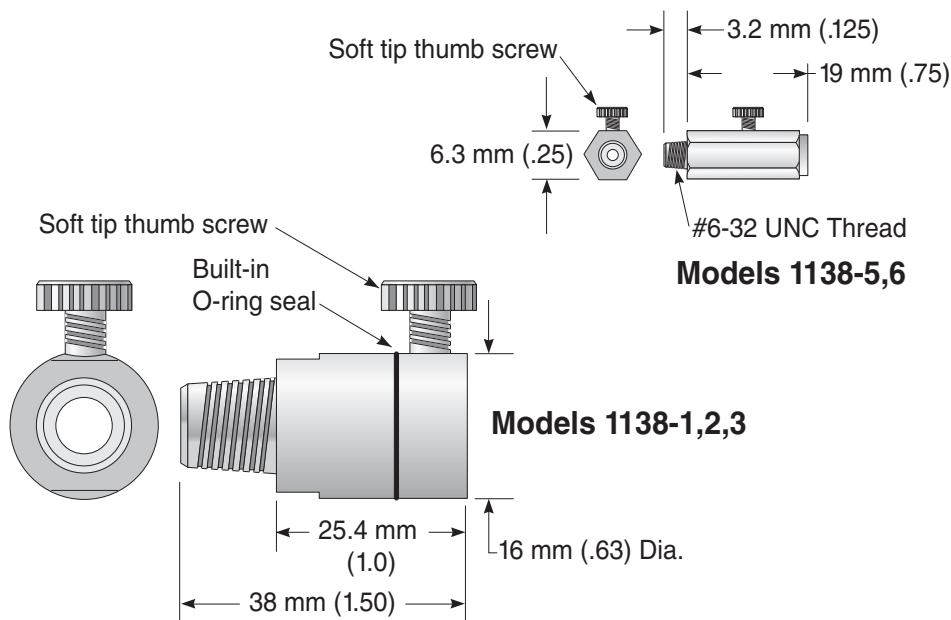

A sealing fitting for probe traversing and for mounting probe supports to the wall of a test section.

**Specify**

- 1138-1 for .250 in. Prot. Sleeve-1/4 NPT
- 1138-2 for .180 in. Probe Support-1/4 NPT
- 1138-3 for .125 in. Standard Probe-1/8 NPT
- 1138-6 for .035 in. Submin. Probe-6-32

## Model 1137 Mounting Block

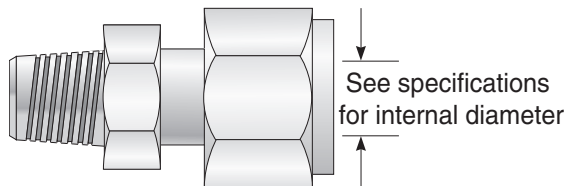

Sealing fittings for probe traversing and for mounting probe supports to the wall of a test section. Has nylon ferrules for higher pressure applications.

**Specify**

- 1137-1 for .250 diameter, 1/4-18 NPT
- 1137-2 for .180 diameter, 1/4-18 NPT
- 1137-3 for .125 diameter, 1/8-27 NPT
- 1137-4 for .060 diameter, 1/8-27 NPT

## Probe Accessories

### Model 1341 Thermocouple Probe

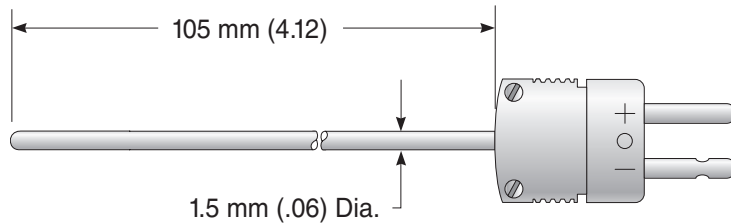

Measures temperature of measurement environment. Type-T copper-constantan.

**Specify**  
1341

### Model 1340 Thermocouple Extension Cable

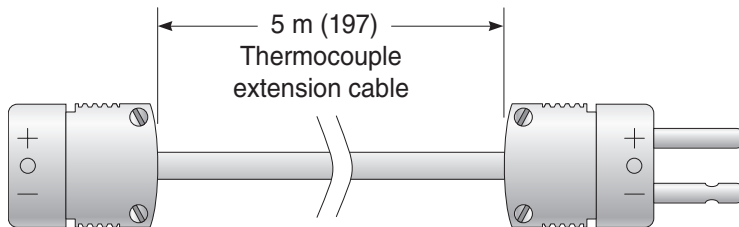

Cable 5 m long connects Model 1340 Thermocouple to anemometer. Type-T copper-constantan.

**Specify**  
1340

### Model 1304 Control Resistor

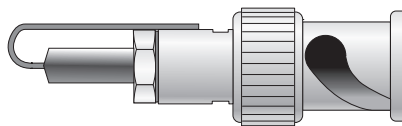

BNC Connector for direct connection to 1050 anemometer or 1750 anemometer

Model 1304 control resistors are used with bridges that have a 5 to 1 ratio, such as 1750 and 1050/1053/1054 anemometers.

**Specify**

1304-XX

where XX is the resistance to the nearest 1 ohm. To determine the correct resistance, refer to equation 2 on page 22.

# Probe Accessories

## Model 10120 Hot Wire/Film Sensor Repair Kit

Includes equipment needed to attach hot wire or cylindrical film sensors designed for gas applications to needle supports. Kit includes soldering iron with spare tips, single-edge razor blades, soldering stand with clip, jeweler's broach, soft solder (400°F melting point), distilled water, brush, acid flux, and a file. A microscope or magnifier of about 10X to 20X is also recommended.

### Specify

10120 for 110 VAC, 60 Hz  
10120-1 for 220 VAC, 50 Hz

## Model 10121 Hot Film Replacement Sensors

These are high-quality, alumina-coated hot film sensors (cylindrical elements for air only) for field replacement use. They are furnished in quantities of 10.

### Specify

10121-10 for 0.025 mm  
(0.0015 in.) dia. with  
0.5 mm (0.020 in.)  
sensor length  
10122-20 for 0.05 mm  
(0.002 in.) dia. with  
1.0 mm (0.040 in.)  
sensor length  
10122-60 for 0.15 mm  
(0.006 in.) dia. with  
2 mm (0.080 in.)  
sensor length

## Model 10122 Hot Wire Replacement Sensors

These are high-quality, platinum-coated tungsten hot wire sensors for field replacement use, furnished in quantities of 12 on a card. The ends of the wires are plated to isolate the active sensor region.

### Specify

10122-T1.5 for 0.0038 mm  
(0.00015 in.) dia. with  
1.25 mm (0.050 in.)  
sensor length  
10122-T2 for 0.005 mm  
(0.0002 in.) dia. with  
1.25 mm (0.050 in.)  
sensor length

## Model 10123 Wire for Hot Wire Sensors

This is the same high-quality, platinum-coated tungsten wire used in the Model 10122 but furnished on a spool in a 2-meter length.

### Specify

10123-T1.5 for 0.0038 mm  
(0.00015 in.) dia. with  
2-meter length of wire  
10123-T2 for 0.005 mm  
(0.0002 in.) dia. with  
2-meter length of wire

# Determining Operating Resistance of a Sensor

Each TSI probe is furnished with complete sensor data showing the recommended operating resistance ( $R_{op}$ ) of the sensor.

Fragile Sensors To be opened only by user					
Probe Model		Serial		TSI Ref. No.	
Sensor No.	Probe RES at 0°C $R_0, \Omega$	$R_{100}-R_0, \Omega$	Recommended Oper. RES $R_{op}, \Omega$	Recommended Oper. Temp. $T_{op}, ^\circ C$	Internal Probe RES $R_{int}, \Omega$
1					
2					
3					

Notes: 1. Control RES (if required) =  $(R_{op} + R_{cable}) \times 5$  on 5:1 BRIDGE  
2.  $R_{int} = R_{sensor} + R_{int}$

Call 1-800-874-2811 for service. Made in U.S.A.

## Example of Sensor Data Label

The operating resistance of the sensor determines the temperature at which the sensor will be operated. Operating resistances are calculated from sensor resistance data taken at 0°C ( $R_0$ ) and 100°C ( $R_{100}-R_0$ ) and include the internal probe resistance ( $R_{int}$ ). The operating resistance listed with each probe corresponds to the recommended operating temperature of the sensor ( $T_{op}$ ) which is also included with the probe. Sensors for use in air or other gases are usually run at temperatures of 250°C, while water sensors are run at 67°C. These sensor temperatures have been selected to optimize sensitivity and signal-to-noise ratio, and provide maximum sensor life. If a different sensor temperature is desired, it can be calculated from:

### Equation 1

$$R_{op} = \frac{T_s (R_{100} - R_0)}{100^\circ C} + R_0$$

where:

- $R_{op}$  = Operating resistance of the sensor (ohms)
- $T_s$  = Desired sensor temperature (°C)
- $R_{100}-R_0$  = Sensor resistance change between 0°C and 100°C (ohms)
- $R_0$  = Sensor resistance at 0°C (ohms)

The operating resistance of the sensor can be set with a variable resistance decade or with a fixed control resistor. The required control resistor value can be determined by:

### Equation 2

$$R_{CR} = (R_{op} + R_c) \times 5$$

(for 5:1 bridge ratio)

where:

- $R_{CR}$  = Control resistor value (ohms)
- $R_c$  = Probe cable resistance, including probe support (ohms)

For TSI 1050 Anemometers with resistance decades, or for IFA 100, IFA 300, and FLOWPOINT™ Anemometers, the operating resistance can be set directly if the probe cable resistance is properly accounted for.

# Probe Calibration

The probe current versus velocity curves\* on page 23 show the sensitivity of various types of sensors. Velocity sensitivity is taken directly from the slope of the curve as amps per units of velocity. To convert from current sensitivity to bridge voltage sensitivity, use the following equation:

### Equation 3

$$\frac{\Delta E_B}{\Delta V} = \frac{\Delta I_s}{\Delta V} (R_{op} + R_B)$$

where:

$\frac{\Delta E_B}{\Delta V}$  = The slope of the calibration curve at the velocity of interest, proportional to the ratio of change in sensor current ( $\Delta I_s$ ) for a small change in velocity ( $\Delta V$ ) past the sensor.

$E_B$  = Bridge voltage

$V$  = Velocity

$R_{op}$  = Sensor operating resistance

$R_B$  = Bridge resistor in series with the sensor (10 ohms for IFA 300 STD Bridge)

The curves can also be used to determine the electrical power dissipated in the sensor or to estimate the approximate bridge voltage at a given velocity:

### Equation 4

$$E_B = I_s (R_{op} + R_B)$$

where:

$E_B$  = Bridge voltage

$I_s$  = Sensor current

$R_{op}$  = Sensor operating resistance

$R_B$  = Bridge resistor

The sensor curves shown are valid only for the sensor resistance listed. For a different resistance sensor, correct the sensor current by:

### Equation 5

$$I_{s_2} = I_{s_1} \sqrt{\frac{R_{op_1}}{R_{op_2}}}$$

where:

$I_{s_2}$  = New sensor current

$I_{s_1}$  = Sensor current from curve

$R_{op_1}$  = Sensor resistance listed on curve

$R_{op_2}$  = Actual sensor resistance

## Sensitivity to Resistance Change

Often in anemometry, questions may arise regarding: 1) Effect of cable length on calibration; 2) "Noise" from slip rings and other types of "contact problems;" 3) Effects of resistance shifts of the sensor; 4) Stability requirements of other resistors in the bridge. These questions all relate to the effect of resistance changes on the output voltage. This can be expressed as:

## Equation 6

$$\frac{\Delta E_B}{\Delta R_{op}} = -\frac{I_s}{2} \frac{(R_{op}/R_B)(2R_{op}/R_e - 1) + 1}{(R_{op}/R_e) - 1}$$

For example, if  $R_{op} = 9$  ohms,  $R_e = 6$  ohms, and  $R_B = 10$  ohms, then:

$$\frac{\Delta E_B}{\Delta R_{op}} = -2.8 I_s (\text{volts/ohm})$$

From the sensor current curves at the right and equation (3), a resistance change can be related to velocity sensitivity.

## Effects of Amplifier Drift

The following relationship gives the ratio of bridge voltage (output) change to a change in amplifier input voltage.

## Equation 7

$$\frac{\Delta E_B}{e_b} = -\frac{I}{2} \left[ 1 + \frac{R_B}{R_{op}} \right] \frac{(R_{op}/R_B)(2R_{op}/R_e - 1) + 1}{(R_{op}/R_e) - 1}$$

Using the above example:

$$\frac{\Delta R_B}{e_B} = -3.63$$

Therefore, a change of 10 microvolts at the amplifier input (equivalent input drift for example) gives only 36.3 microvolts at the anemometer output for the assumed conditions. A constant temperature anemometer is inherently a very stable instrument.

## Conduction Loss to Supports

The steady-state effects of conduction losses to supports have little influence on the mean velocity accuracy if the sensor is properly calibrated. Only when attempts are made to predict the calibration heat transfer equations will the steady state conduction to supports become a factor. In noncylindrical film sensors, the dynamic effects of nonsteady state heat conduction to the supporting structure can be significant, particularly in gases. For example, the high frequency (compensated) sensitivity can be less than half of that predicted by a steady-state calibration curve. The actual attenuation depends on many factors including the size and shape of the sensor and its environment. In general, the high heat transfer rates in water reduce this error to acceptable levels, while in gases a dynamic calibration is required for optimum results. It should be emphasized that this effect is usually negligible in both hot wires and cylindrical film sensors. This is because the conduction loss to the supports is small and the supports are a sufficiently large heat sink so their temperature change is small.

\*Curves are for typical sensors. Actual sensors will vary.

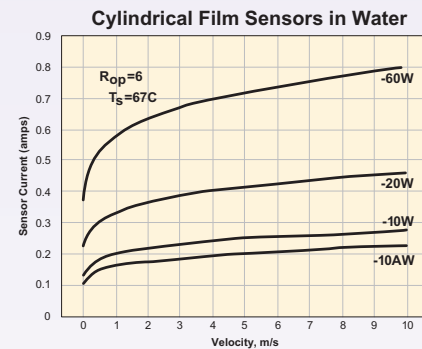
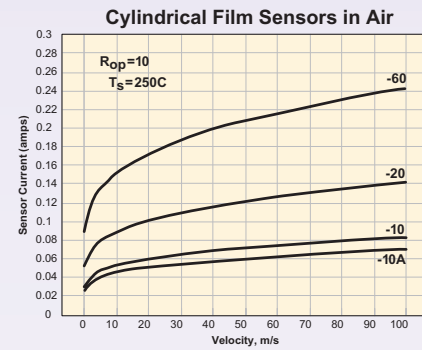
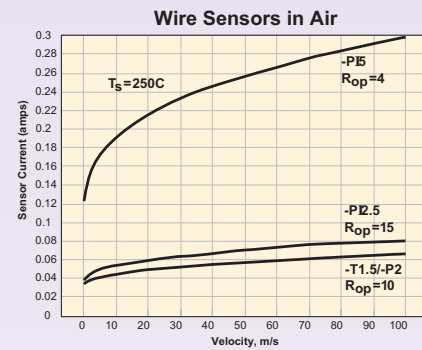

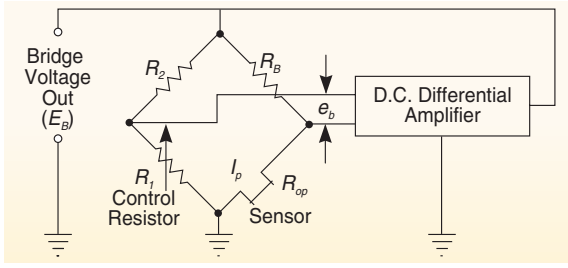

Schematic of Constant Temperature Anemometer

## Calibration Adjustments

Calibrations are made by plotting Bridge Voltage,  $E_B$ , as a function of Velocity and then fitting the data with a polynomial or exponential curve fit. If the calibration must be adjusted for use with a different bridge resistance,  $R_B$ , or cable resistance,  $R_c$ , it is useful to assume that the sensor current is constant (for a given velocity and sensor temperature). For convenience, internal probe resistance is included in sensor resistance data, but probe support resistance can be measured or nulled out and should be included with cable resistance,  $R_c$ . Then we can calculate a new bridge voltage for each velocity.

### Equation 8

$$I_s = \frac{E_B}{(R_B + R_c + R_{op})}$$

and so:

$$E'_B = E_B \frac{(R'_B + R'_c + R_{op})}{(R_B + R_c + R_{op})}$$

## Temperature Sensitivity

Bridge Voltage is corrected for ambient temperature changes as follows. A reasonable assumption is that

$$\frac{E_B^2}{(T_s - T)}$$

is constant for a given velocity as temperature changes. Therefore, we can predict a bridge voltage  $E'_B$  for a new temperature,  $T'$ , as follows.

### Equation 9

$$E'_B = E_B \left[ \frac{T_s - T'}{T_s - T} \right]^{1/2}$$

## Directional Sensitivity of Cylindrical Sensors

The following provides a very brief introduction to techniques for measurements with cylindrical thermal sensors. To simplify this presentation, it is assumed that the sensor is sufficiently long so that the following approximation can be used:

### Equation 10

$$V_{eff} = V \cos \alpha$$

In other words, the effective cooling velocity past the sensor varies as the cosine of the angle between the sensor axis and the velocity vector. At  $90^\circ$ ,  $V_{eff} = 0$  and at  $0^\circ$   $V_{eff} = V$ . It should be noted that in the ideal case, the sensitivity remains constant as the velocity vector moves around the sensor at a constant angle,  $\alpha$ , to the sensor axis.

## Single Sensor Oriented Perpendicular to the Mean Flow

Let the mean flow be represented by  $V_1$  and the fluctuations represented by  $v_1$ ,  $v_2$ , and  $v_3$  where  $v_2$  represents the fluctuations in the direction parallel to the sensor and  $v_3$  represents the fluctuations in a direction perpendicular to  $v_1$  and  $v_2$ . The effective velocity measured will be:

### Equation 11

$$V_{eff} = \sqrt{(\bar{V}_1 + v_1)^2 + v_2^2 + v_3^2}$$

If we neglect  $v_3$ , then:

$$\bar{V}_1 = \bar{V} = \bar{V}_{eff}$$

and

$$\sqrt{v_1^2} = \sqrt{v_{eff}^2}$$

The value of  $V_1$  is the average value while

$$\sqrt{v_1^2}$$

is the rms value.

When

$$\sqrt{v_1^2} / \bar{V} = 0.2$$

(= 20% turbulence intensity), the error due to ignoring  $v_3$  is about 2% for isotropic, normally distributed, and normally correlated turbulence.† The mean velocity error is also about 2%.

## X Probe (Two cylindrical sensors oriented at $90^\circ$ to each other)

The X probe is used to measure two velocity components. Writing the equations for the effective velocity for the two sensors "A" and "B" with the mean velocity in the plane of the two sensors  $V_3 = 0$  and  $\bar{\alpha}_1 =$  the angle between  $V_1$  and sensor B gives:

### Equation 12

$$V_{A,eff}^2 = (V_1 \cos \alpha_1 - V_2 \sin \alpha_1)^2 + v_3^2$$

$$V_{B,eff}^2 = (V_1 \sin \alpha_1 + V_2 \cos \alpha_1)^2 + v_3^2$$

If the sensors are further aligned so  $\alpha_1 = 45^\circ$  and  $v_3^2$  is assumed negligible, then rearranging the above equations gives:

### Equation 13

$$V_I = 2^{-1/2} (V_{A,eff} + V_{B,eff})$$

Finally, if the sensors are aligned so that  $\bar{V}_2 = 0$  and  $\bar{V}_1 = \bar{V}$ , then:

### Equation 14

$$\bar{V} = 2^{-1/2} (V_{A,eff} + V_{B,eff})$$

$$\overline{v_1^2} = 2^{-1} (v_{A,eff} + v_{B,eff})^2$$

$$\overline{v_2^2} = 2^{-1} (v_{A,eff} - v_{B,eff})^2$$

$$\overline{v_1 v_2} = 2^{-1} (v_{A,eff} + v_{B,eff})(v_{A,eff} - v_{B,eff})$$

Neglecting  $v_3$  gives an error of about 8% when the turbulence intensity is 20%, with the same flow field as discussed for the single wire.†

The above is given here to provide some insight into how single sensors and X probes are used and the limitations at high turbulence intensities. Refinements of the equations as well as other considerations are contained in the extensive literature on thermal sensors contained in the Freymuth bibliography.

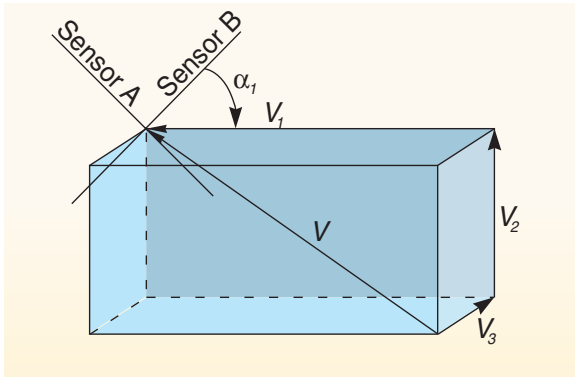

Configuration of X-probe.

### Nomenclature

$E_B$	= bridge voltage output
$\Delta E_B$	= small change in bridge voltage output
$e_b$	= small voltage change at amplifier input
$f$	= frequency, (Hz)
$I_s$	= current through sensor (amps)
$\Delta I_s$	= small change in sensor current
$R_c$	= probe cable resistance (includes probe support resistance, but not internal probe resistance)
$R_{CR}$	= control resistor value
$R_e$	= resistance of sensor at ambient (environment) fluid temperature (ohms)
$R_o$	= sensor resistance at 0°C
$R_{op}$	= resistance of sensor at operating temperature
$\Delta R_{op}$	= small change in sensor resistance
$R_B$	= bridge resistor in series with the sensor, 10 ohms for FLOWPOINT, IFA 100, IFA 300 except 2 ohms for IFA 100, IFA 300 Hi Power Bridge; 40 ohms for Model 1053B, 1054A, 1054B, and #1 Bridge on Model 1050; 10 ohms for #2 Bridge on Model 1050 and 2 ohms on #3 Bridge on Model 1050; 20 ohms for Model 1750.
$T$	= fluid temperature
$T_s$	= sensor operating temperature (°C)
$V$	= fluid velocity past sensor
$\Delta V$	= small change in fluid velocity past sensor
$V_1, V_2, V_3$	= orthogonal components of $V$ relative to flow facility
$V_{eff}$	= effective cooling velocity past sensor (equivalent value of $V_A$ )
$V_{A,eff}$	= effective velocity as seen by sensors (and similarly for sensor B)
$v$	= small fluctuations in velocity $V$
$\alpha_1$	= angle between velocity vector and sensor axis

†S.P. Parthasarathy and D.J. Tritton, "Impossibility of Linearizing Hot-Wire Anemometer for Turbulent Flows," AIAA J., vol. 1, pp. 210-211, 1963.

# Index

Model	Description	Pg.	Model	Description	Pg.
1108	BNC Subminiature Probe Adapter	19	1240	Standard Cross Flow "X" Probe	10
1132	Wire Shield	18	1241	End Flow "X" Probe	10
1133	Miniature Wire Shield	18	1243	Boundary Layer Cross Flow "X" Probe, Sensors Upstream	12
1137	Mounting Block	19	1244	End Flow Parallel Sensor Probe	12
1138	Mounting Block	19	1245	Cross Flow "X" Probe, Sensors Upstream	11
1139	Shield with Window	18	1246	Cross Flow "X" Probe, Sensors Upstream	11
1150	Standard Probe Support	14	1247A	Miniature Cross Flow "X" Probe	11
1151	Probe Support	14	1248A	Miniature End Flow "X" Probe	10
1152	90° Angle Adapter	15	1249A	Miniature Cross Flow "X" Probe, Sensors Upstream	12
1154	Dual Sensor Probe Support for Liquids	17	1260A	Miniature Straight Probe	6
1155	Standard Dual Sensor Probe Support	16	1261A	Miniature Boundary Layer Probe	9
1156	Dual Sensor Probe Support	16	1262A	Miniature Probe	8
1157	90° Angle Adapter	17	1276	Subminiature Straight Probe	7
1158	Locking Protective Shield	18	1277	Subminiature Probe	8
1159	Immersible Probe Support	15	1299	End Flow 3-D Probe	13
1160	High Temperature Probe Support	14	1299A	Cross Flow 3-D Probe	13
1201	Disposable Probe	6	1304	Control Resistor	20
1210	General Purpose Probe	6	1340	Thermocouple Extension Cable	20
1211	Standard Probe	7	1341	Thermocouple Probe	20
1212	Standard Single Sensor Probe	8	10120	Hot Wire/Film Sensor Repair Kit	21
1213	Sensor 45° to Probe	7	10121	Hot Film Replacement Sensors	21
1214	Streamlined Probe	7	10122	Hot Wire Replacement Sensors	21
1218	Standard Boundary Layer Probe	9	10123	Wire for Hot Wire Sensors	21
1220	High Temperature Straight Probe	6			
1222	High Temperature Single Sensor Probe	8			



TSI Incorporated serves a global market by investigating, identifying and solving measurement problems. As an industry leader in the design and production of precision instruments, TSI partners with research institutions and customers around the world to set the standard for measurements relating to aerosol science, air flow, indoor air quality, fluid dynamics and biohazard detection. With headquarters based in the U.S. and field offices throughout Europe and Asia, TSI has established a worldwide presence in the markets we serve. Every day, our dedicated employees turn research into reality.

---

**TSI Incorporated** - 500 Cardigan Road, Shoreview, MN 55126-3996 USA

<b>USA</b>	<b>Tel:</b> +1 800 874 2811	<b>E-mail:</b> fluid@tsi.com	<b>Website:</b> www.tsi.com
<b>UK</b>	<b>Tel:</b> +44 149 4 459200	<b>E-mail:</b> tsiuk@tsi.com	<b>Website:</b> www.tsiinc.co.uk
<b>France</b>	<b>Tel:</b> +33 491 95 21 90	<b>E-mail:</b> tsifrance@tsi.com	<b>Website:</b> www.tsiinc.fr
<b>Germany</b>	<b>Tel:</b> +49 241 523030	<b>E-mail:</b> tsigmbh@tsi.com	<b>Website:</b> www.tsiinc.de
<b>Sweden</b>	<b>Tel:</b> +46 8 595 13230	<b>E-mail:</b> tsiab@tsi.com	<b>Website:</b> www.tsi.se
<b>India</b>	<b>Tel:</b> +91 80 41132470	<b>E-mail:</b> tsi-india@tsi.com	
<b>China</b>	<b>Tel:</b> +86 10 8260 1595	<b>E-mail:</b> tsibeijing@tsi.com	



TRUST. SCIENCE. INNOVATION.

Contact your local TSI Distributor or visit our website [www.tsi.com](http://www.tsi.com) for more detailed specifications.