



Transmitters - GAS DETECTION DATASHEET

AST-IS Industrial CO₂ Transmitters



AST-IS transmitter contains an infrared sensor for accurate, reliable carbon dioxide (CO₂) detection.

AST-IS transmitters convert the raw signal from a sensor into a useful output that can be sent to a controller or building automation system.

Standard enclosure is an attractive PVC office mount for indoor use. Optional duct mount, LCD digital display, relay, IP54 enclosure, and temperature sensor are available.

AST-IS transmitters feature 4 - 20 mA or 0 - 10 VDC linear output signals, low 24 VDC / VAC nominal voltage, standard 0 - 2,000 ppm range and 0 - 6% volume available for winery applications, and CE certification.

Lifetime calibration. Field calibration not required.

KEY FEATURES

- » 4 - 20 mA or 0 - 10 VDC linear output signal
- » Operating power 24 VDC or 24 VAC nominal
- » Lifetime calibration
- » 0 - 2,000 ppm standard range
- » Optional relay, LCD digital display & duct mount kit
- » CE certified

APPLICATIONS

- » Residential Buildings
- » Commercial Buildings
- » Greenhouses
- » Schools / Educational Institutions
- » Offices
- » ... and many more

TECHNICAL DRAWING

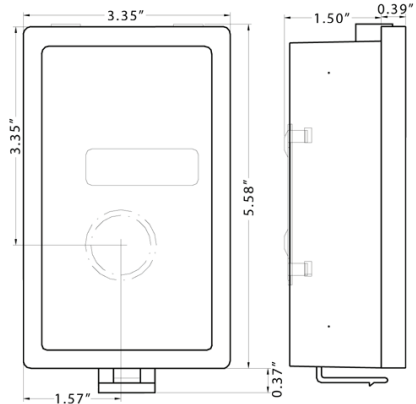

SAMPLE ENGINEERING SPECIFICATIONS

Coming soon...

WIRING

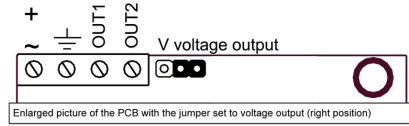
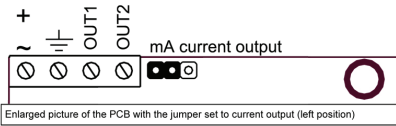

TECHNICAL SPECIFICATIONS

GAS TYPE

Carbon Dioxide (CO₂)

MECHANICAL

Enclosure	General purpose PVC (IP54 rated)
Weight	<i>tbd</i>
Size	5.6" x 3.3" x 1.8" (142 mm x 84 mm x 46 mm)

ELECTRICAL

Power Requirement	24 VDC or VAC
Outputs	Linear 4 - 20 mA or 0 - 10 VDC signal

SENSOR

Sampling Method	Non-dispersive infrared
Monitoring Method	Diffusion
Range	0 - 2,000 ppm
Accuracy	± 30 ppm, ± 3% of reading

ENVIRONMENTAL (sensor dependent)

Operating Temperature	0°C to 50°C (32°F to 122°F)
Humidity	0 - 95% RH non-condensing

CERTIFICATION

CE	Certified
----	-----------

PRODUCT CODES

Carbon dioxide (CO ₂), duct mount	AST-IS3
Carbon dioxide (CO ₂), duct mount with LCD digital display	AST-IS4
Carbon dioxide (CO ₂), wall mount with IP54 industrial enclosure	AST-IS6
Carbon dioxide (CO ₂), wall mount with IP54 industrial enclosure & LCD digital display	AST-IS7
Carbon dioxide (CO ₂) & temperature sensor, duct mount	AST-IS8
Carbon dioxide (CO ₂) & temperature sensor, wall mount with IP54 industrial enclosure & relay	AST-IS13
Carbon dioxide (CO ₂), duct mount with LCD digital display	AST-IS17
Carbon dioxide (CO ₂), wall mount with IP54 industrial enclosure, 0 - 6% volume	AST-IS18