

Model 9306A Six-Jet Atomizer

Instruction Manual

*P/N 1930099, Revision B
February 2003*



Manual History

The following is a manual history of the Model 9306A Six-Jet Atomizer Instruction Manual (part number 1930099)

Revision	Date
New Version	November 1998
A	August 2000
B	February 2003

This new version replaces the Model 9306 Six-Jet Atomizer instruction manual (part number 1990143) and TSI's area code was changed from 612 to 651.

In revision A, TSI's Limitation of Warranty and Liability was updated.

In revision B, TSI phone numbers and address were updated.

Part Number
Copyright
Address
Fax No.
E-mail Address
**Limitation of Warranty
and Liability**
(effective July 2000)

1930099 / Revision B / February 2003

©TSI Incorporated / 1993–2003 / All rights reserved.

TSI Incorporated / 500 Cardigan Road / Shoreview, MN 55126 / USA

651-490-3824

particle@tsi.com

Seller warrants the goods sold hereunder, under normal use and service as described in the operator's manual, shall be free from defects in workmanship and material for (12) months, or the length of time specified in the operator's manual, from the date of shipment to the customer. This warranty period is inclusive of any statutory warranty. This limited warranty is subject to the following exclusions:

- a. Hot-wire or hot-film sensors used with research anemometers, and certain other components when indicated in specifications, are warranted for 90 days from the date of shipment.
- b. Parts repaired or replaced as a result of repair services are warranted to be free from defects in workmanship and material, under normal use, for 90 days from the date of shipment.
- c. Seller does not provide any warranty on finished goods manufactured by others or on any fuses, batteries or other consumable materials. Only the original manufacturer's warranty applies.
- d. Unless specifically authorized in a separate writing by Seller, Seller makes no warranty with respect to, and shall have no liability in connection with, goods which are incorporated into other products or equipment, or which are modified by any person other than Seller.

The foregoing is IN LIEU OF all other warranties and is subject to the LIMITATIONS stated herein. **NO OTHER EXPRESS OR IMPLIED WARRANTY OF FITNESS FOR PARTICULAR PURPOSE OR MERCHANTABILITY IS MADE.**

TO THE EXTENT PERMITTED BY LAW, THE EXCLUSIVE REMEDY OF THE USER OR BUYER, AND THE LIMIT OF SELLER'S LIABILITY FOR ANY AND ALL LOSSES, INJURIES, OR DAMAGES CONCERNING THE GOODS (INCLUDING CLAIMS BASED ON CONTRACT, NEGLIGENCE, TORT, STRICT LIABILITY OR OTHERWISE) SHALL BE THE RETURN OF GOODS TO SELLER AND THE REFUND OF THE PURCHASE PRICE, OR, AT THE OPTION OF SELLER, THE REPAIR OR REPLACEMENT OF THE GOODS. IN NO EVENT SHALL SELLER BE LIABLE FOR ANY SPECIAL, CONSEQUENTIAL OR INCIDENTAL DAMAGES. SELLER SHALL NOT BE RESPONSIBLE FOR INSTALLATION, DISMANTLING OR REINSTALLATION COSTS OR CHARGES. No Action, regardless of form, may be brought against Seller more than 12 months after a cause of action has accrued. The goods returned under warranty to Seller's factory shall be at Buyer's risk of loss, and will be returned, if at all, at Seller's risk of loss.

Buyer and all users are deemed to have accepted this LIMITATION OF WARRANTY AND LIABILITY, which contains the complete and exclusive limited warranty of Seller. This LIMITATION OF WARRANTY AND LIABILITY may not be amended, modified or its terms waived, except by writing signed by an Officer of Seller.

Service Policy

Knowing that inoperative or defective instruments are as detrimental to TSI as they are to our customers, our service policy is designed to give prompt attention to any problems. If any malfunction is discovered, please contact your nearest sales office or representative, or call TSI's Customer Service department at 1-800-874-2811 (USA) or (651) 490-2811.

Contents

Manual History	ii
About This Manual	vii
Purpose	vii
Getting Help.....	vii
Submitting Comments	vii

Sections

Subassemblies	1
Pressure Regulator.....	2
Atomizers.....	2
Dilution System	2
Aerosol Outlet.....	2
Operating the Atomizer	3
Adding Atomizer Liquid	3
Connecting the Compressed Air	3
Connecting the Aerosol Outlet.....	5
Setting the Regulator Pressure	5
Operating the Jets	5
Operating Characteristics	5
Aerosol Flowrate	5
Particle Output	6
Maintenance	7
Cleaning	7
Clogged Jets	9
Seed Materials	9
Liquid Particles	9
Solid Particles	9
NaCl or Sugar	9
Monodisperse Latex Particles	9
Specifications	12
References	13

Figures

1	Model 9306A Six-Jet Atomizer, Outline Drawing.....	1
2	Schematic Drawing of the Aerosol Outlet and Atomizer Assemblies; the Numbers Give the Order for Disassembling the Instrument	4
3	Relationship Between Number of Atomizer Particles Generated and Input Pressures.....	7
4	How to Disassemble the Atomizer for Cleaning	8
5	Particle Size Distribution of a 0.797-micrometer Monodisperse PSL Aerosol.....	10
6	Particle Size Distribution of a 2.02-micrometer Monodisperse PSL Aerosol.....	11

Tables

1	Aerosol Flowrate Per Jet	6
2	Specifications for the Model 9306A Six-Jet Atomizer.....	12

About This Manual

Purpose

This manual describes and gives installation information for the Model 9306A Six-Jet Atomizer.

Getting Help

To report damaged or missing parts, for service information or technical or application questions, contact:

TSI Incorporated (Particle Instruments)
500 Cardigan Road
Shoreview, MN 55126 USA
Fax: (651) 490-3824
Telephone: 1-800-874-2811 (USA) or (651) 490-2811
E-mail: particle@tsi.com

Submitting Comments

TSI values your comments and suggestions on this manual. Please use the comment sheet, on the last page of this manual, to send us your opinion on the manual's usability, to suggest specific improvements, or to report any technical errors.

If the comment sheet has already been used, fax, mail, or e-mail your comments to:

Technical Writer (Particle Instruments)
TSI Incorporated
500 Cardigan Road
Shoreview, MN 55126
Fax: (651) 490-3824
E-mail: particle@tsi.com

Model 9306A Six-Jet Atomizer

The Model 9306A incorporates several special features which makes it a convenient and flexible instrument. The system has a built-in pressure regulator and pressure gauge. It also has a self-contained dilution system and can select one to six particle-generating atomizer jets. The result is a broad range of control over both the particle number concentration and over the total particle output.

The atomizer can generate particles from virtually any liquid. It can even produce solid particles from solutions or from suspensions, for example, particles from uniform polystyrene latex (PSL) spheres.

Subassemblies

This section describes the atomizer's four subassemblies and their functions: the pressure regulator, atomizers, dilution system, and aerosol outlet. Figure 1 identifies these subassemblies on the atomizer.

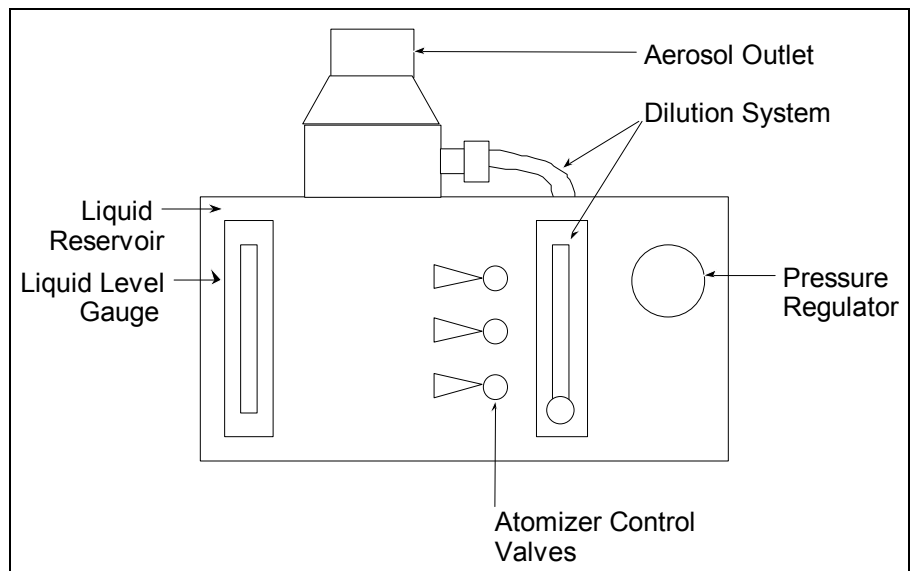

Figure 1
Model 9306A Six-Jet Atomizer, Outline Drawing

Pressure Regulator

A regulator and pressure gauge are mounted on the atomizer. The regulator controls the input pressure which is displayed on the gauge. The precise relationship between input pressure and aerosol output is discussed later under “Operating Characteristics.”

Atomizers

All six atomizers may be used at one time. Figure 2 shows one of the six individual particle-generating atomizers within the liquid reservoir.

The operating principle of the atomizer is simple. As shown in Figure 2, pressurized air forms a high-velocity jet through a 0.015-inch-diameter orifice. The pressure drop from this jet draws liquid up through a narrow tube. The liquid is then broken up into droplets by a high-velocity air jet. The resultant larger droplets impinge on the spherical impactor, while the smaller droplets make no contact and form an aerosol that exits through a specific outlet.

Dilution System

The atomizer incorporates an aerosol dilution system. Dilution air is used to vary the output concentration and to help dry the solid particles that are generated from a solution.

A rotometer is mounted next to the regulator which gives the flowrate of the dilution air.* A valve at the base of the rotometer controls the flowrate.

Aerosol Outlet

Figure 2 shows the outlet assembly in cross-section and outlines the basic operation. The assembly meets the high aerosol output that is demanded when all six atomizer jets are used and/or when high dilution-air settings are used.

*The dilution air that is available to the atomizer diminishes when the input pressure falls below 20 psig.

The relatively large aerosol outlet was selected to maintain low aerosol velocities.

Operating the Atomizer

Adding Atomizer Liquid

Remove the red plastic filler cap on the cover of the reservoir and pour in the liquid to be atomized.

Observe the liquid level shown in the glass gauge on the front panel. Fill the reservoir no more than half to ensure that the atomizing jets are not submerged.

Connecting the Compressed Air

Be sure to close both the regulator valve and the dilution air valve before connecting the compressed air. To close the regulator, turn its knob counterclockwise until at least three-fourths of an inch of shaft is exposed. To close the dilution air valve, turn it fully clockwise.



C a u t i o n

The compressed air source must not exceed the regulator's maximum pressure specification of 250 psig.

Now connect a source of clean compressed air to the atomizer at the inlet fitting on the pressure regulator.

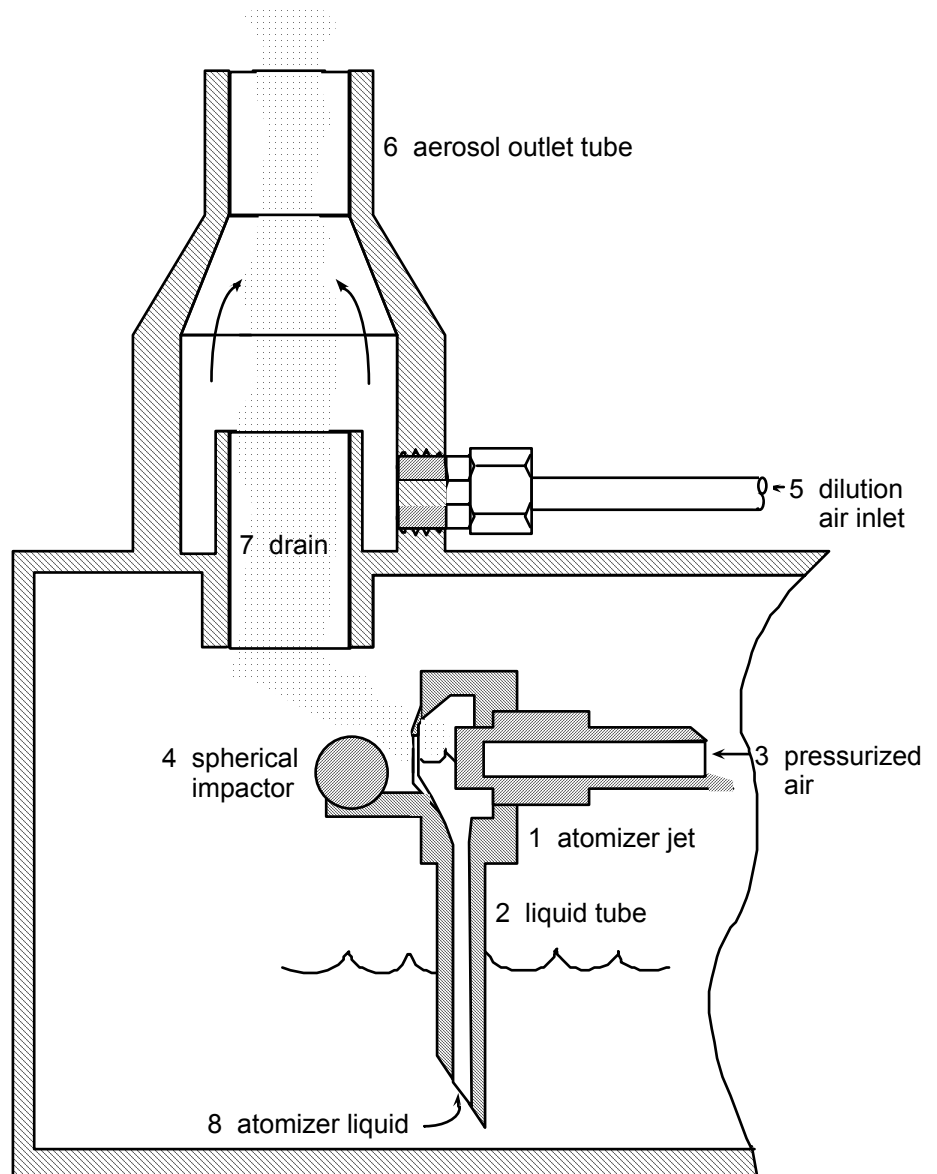

Figure 2
 Schematic Drawing of the Aerosol Outlet and Atomizer Assemblies; the Numbers Give the Order for Disassembling the Instrument

Connecting the Aerosol Outlet

Connect the atomizer to the flow system that is to be seeded using 1-inch ID flexible tubing (Tygon[®], for example). Slip the tubing over the aerosol outlet. Under atmospheric conditions, no hose clamp is necessary.

Setting the Regulator Pressure

The atomizer works well under input pressures between 20 and 50 pounds per square inch. At atmospheric conditions, an input pressure of 25 pounds per square inch is typical.

Operating the Jets

Open the jet or jets needed. Three *on/off* valves control their operation. The label beneath each valve indicates the number of jets that each valve controls. Thus, the valve labeled 1 JET controls a single jet; the valve labeled 2 JETS controls two additional jets, while the valve labeled 3 JETS controls three additional jets. From one to six jets may be operated by opening the appropriate valve(s). In other words, if the valves labeled 1 JET and 3 JETS are open, a total of four jets would be in operation.

Operating Characteristics

Aerosol Flowrate

Table 1 shows typical flowrates at several input pressures. This data is valid for a single atomizer jet at atmospheric pressure. The total aerosol flowrate is directly proportional to the number of jets used.

If the atomizer is used to seed a flow under pressure, the aerosol output will naturally differ from the value given in Table 1.

[®]Tygon is a registered trademark of Norton Performance Plastics Corporation.

Table 1
Aerosol Flowrate Per Jet

Input Pressure	Aerosol Output*
psi kPa	L/min
5 34.5	2.4
10 68.9	3.7
15 103.0	4.7
20 138.0	5.7
25 172.0	6.6
35 241.0	8.3
45 310.0	10.2
55 379.0	12.0

*Outlet open to the atmosphere.

Particle Output

The total particle output depends on the input pressure and the number of jets operated. At fixed input pressures, the particle output is directly proportional to the number of jets that are open.

When the input pressure changes, the particle output changes as graphed in Figure 3.

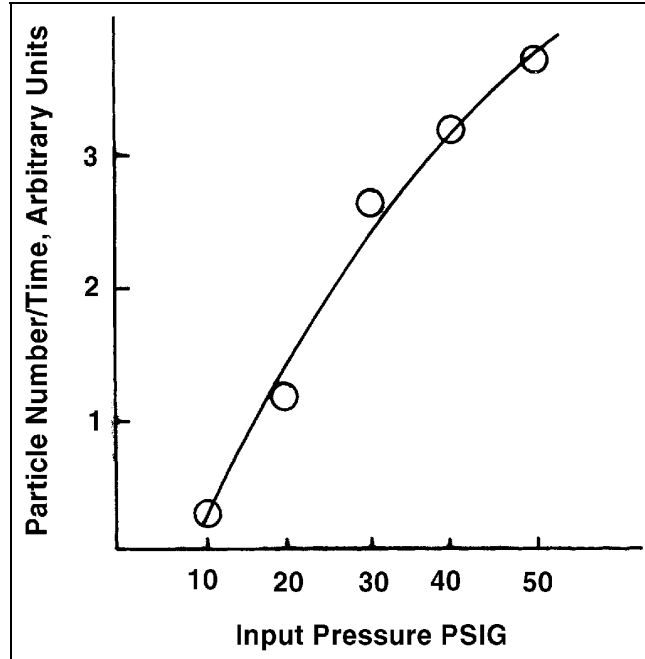

Figure 3
Relationship Between Number of Atomizer Particles Generated and Input Pressures

Maintenance

Routine maintenance on the atomizer is typically unnecessary. There are times, however, when you should clean the generator, typically before using a different liquid.

Cleaning

Cleaning should be limited to those components that come in contact with the atomizer liquid, for example, the liquid reservoir, the atomizers, and the outlet assembly. Figure 4 shows an exploded view of these components; the numbers give the order in which the parts should be disassembled. You can clean the atomizer better if you separate its components. Often it is unnecessary to disassemble the generator before cleaning it. Simply empty the old

liquid from the reservoir and rinse it several times with a suitable solvent.*

After draining the excess solvent, allow the reservoir to dry; then add the new liquid. Note, however, that this simplified cleaning method will probably cause mild contamination of the new liquid.

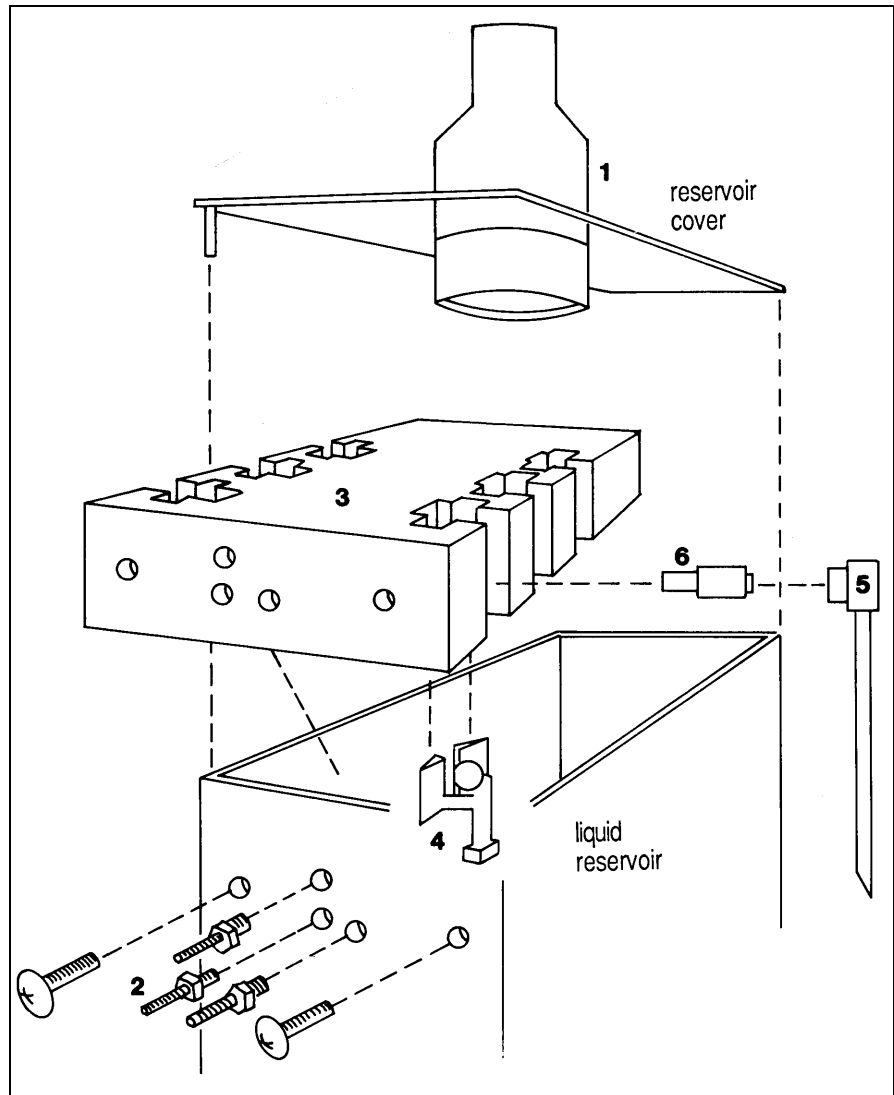

Figure 4
How to Disassemble the Atomizer for Cleaning

*A suitable solvent readily mixes with the atomizer liquid and evaporates quickly. Isopropanol and water are common.

Clogged Jets

Occasionally the atomizer jets may become clogged.** Typically, the atomizer liquid is not clean. You must remove the jets in order to clean them (Figure 4).

Seed Materials

Liquid Particles

The atomizer is used most often for generating liquid seed particles because liquid particles are spherical, inexpensive, and can be generated by the atomizer at high concentrations. Typical materials would include Dioctyl Phthalate (DOP), Polyethylene Glycol 400, Oleic Acid, Olive Oil, and Propylene Glycol.

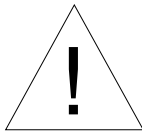

C a u t i o n

Proper ventilation is needed to prevent inhalation exposure to the generated aerosols. The long-term effects of ingesting or inhaling many compounds, including some described here, are still unknown.

Solid Particles

NaCl or Sugar

NaCl or sugar particles may be generated in the atomizer by atomizing a solution of these solids. Once completely dried, the final size of the particles depends on the concentration of the solution used; thus, a lower solids concentration yields smaller particles. Since the solubility of sugar is higher than NaCl, sugar is preferred when particles larger than 1 micrometer are desired.

Monodisperse Latex Particles

A monodisperse aerosol can be generated by dispersing uniform PSL particles using the atomizer. The resultant monodisperse PSL aerosols are very useful for system evaluation and calibration.

**When cleaning an atomizer jet, be careful not to damage its orifice.

To generate PSL particles, make a very dilute solution (about two to three drops in one liter of distilled water) and atomize the solution with the atomizer as described previously under “Operation.”

1. It is important that the solution be sufficiently diluted so that the probability of a liquid droplet containing more than a single PSL particle is low. This becomes more important when the aerosol is intended for system calibration. For seeding, a more concentrated solution may be used (10 drops per liter).

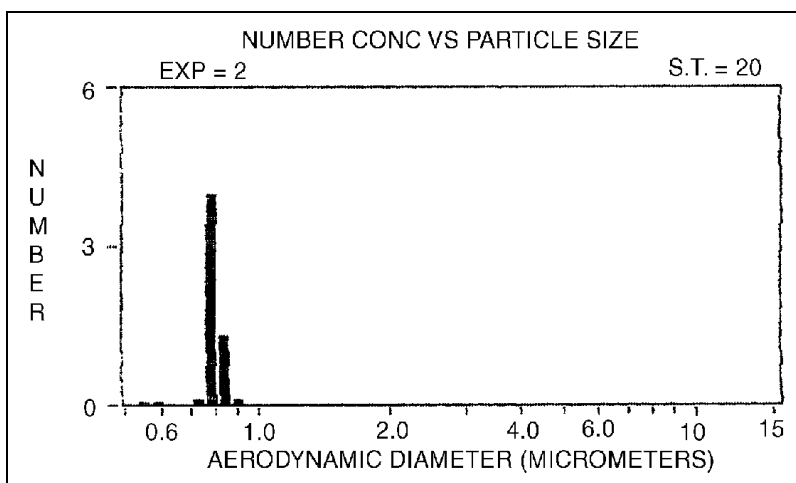

Figure 5
Particle Size Distribution of a 0.797-micrometer Monodisperse PSL Aerosol

2. When a very dilute solution is atomized, many water droplets contain no PSL particles. When these empty water droplets dry out, they are reduced to small residual particles. Thus, the particles generated by this technique always contain both the particles of desired size and smaller residue particles. The presence of residue particles is discussed in Whitby and Liu [4].
3. An aerosol of original particle size is obtained only after the liquid droplets are completely dry. Mixing the aerosol with a sufficient volume of warm, dry air is perhaps the best way of drying the particles. A simple system for drying the droplets is described in Agarwal and Fingerson [3].

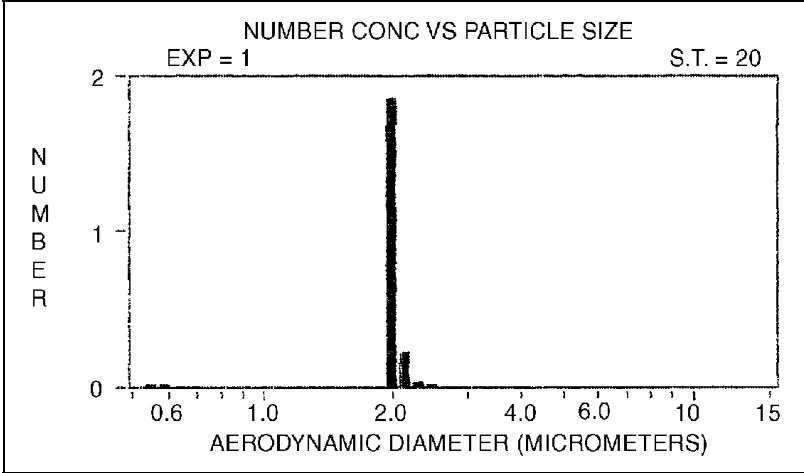

Figure 6
Particle Size Distribution of a 2.02-micrometer Monodisperse PSL Aerosol

Specifications

The following specifications—which are subject to change—list the features of the Model 9306A Six-Jet Atomizer.

Table 2
Specifications for the Model 9306A Six-Jet Atomizer

Number mean droplet diameter ..	0.35 μm for water, 0.3 μm for DOP
Geometric standard deviation	<2
Particle concentration	$>10^6$ particles/ cm^3
Particle material	PSL, DOP, DEHS, oils, and other aqueous or alcohol solutions or suspensions
Maximum PSL particle size	4 μm
Number of jets	6 (selectable)
Flowrate per jet	6.5 L/min at 170 kPa (25 psig), 12 L/min at 380 kPa (55 psig)
Normal operating pressure	170 kPa (25 psig)
Maximum inlet pressure	550 kPa (80 psig)
Maximum outlet pressure	102 kPa (15 psig)
Materials of construction	Anodized aluminum, plastic
Outlet port dimensions	2.5 cm (1.0 in.)
Instrument dimensions (LWH)	32 cm \times 12.5 cm \times 26 cm (12.6 in. \times 4.9 in. \times 10.2 in.)
Weight	2.7 kg (1.2 lb)

References

1. Agarwal, J. K. and Johnson, E. M.
“Generating Aerosol for Laser Velocimeter Seeding”
TSI Quarterly, Vol. III, No. 3 (1981) (Appendix A)
2. Agarwal, J. K. and Fingerson, L. M.
“Real-time Aerodynamic Particles Size Measurement with a Laser Velocimeter”
TSI Quarterly, Vol. V, No. 1 (1979)
3. Argawal, J. K. and Fingerson, L. M.
“Evaluation of Various Particles for Their Suitability as Seeds in Laser Velocimetry”
Laser Velocimetry and Particle Sizing
Edited by H. D. Thompson and W. H. Stevenson (New York: Hemisphere Publishing Corporation, 1978)
4. Whitby, K. T. and Liu, B. Y. H.
“Polystyrene Aerosols—Electrical Charge and Residue Size Distribution”
Atmosphere Environment, Vol. 2, pp. 103–116



TSI Incorporated
500 Cardigan Road, Shoreview, MN 55126 U.S.A.
Web: www.tsi.com